



GAIL GAS LTD

(A wholly owned subsidiary of GAIL (India) Limited)

CNG AND CITY GAS DISTRIBUTION PROJECT

BID DOCUMENT FOR

PROCUREMENT OF CARBON STEEL BARE / COATING / COATED LINE PIPES VOLUME – II OF II (TECHNICAL)

(BID DOCUMENT NO: 110290/WGI/GAIL GAS/14-R0)

OPEN DOMESTIC COMPETITIVE BIDDING



DELIVERS. EVOLVES.

WHOLE LIFE SOLUTIONS FOR PIPELINE AND SUBSEA SYSTEMS

ISSUED BY

J P KENNY



JP KENNY



GAIL GAS LIMITED
CITY GAS DISTRIBUTION PROJECT



VOLUME II OF II (TECHNICAL) BIDDING DOCUMENT FOR CARBON STEEL COATED LINE PIPES	CLIENT JOB NO.	-
	TOTAL SHEETS	02

DOCUMENT NO	110290 / WGI / GAIL GAS / 14-RO
--------------------	---------------------------------



REV	DATE	DESCRIPTION	PREP	CHK	APPR
0	4.11.09	ISSUED FOR CLIENT COMMENTS	MH	SB	SB
A	29.10.09	ISSUED FOR IDC	MH	SB	SB

INDEX

S.NO.	DOCUMENTS DESCRIPTION	DOCUMENTS NO.	NO. OF PAGES
1	Scope of work for procurement of coated line pipes	11-0290-02-07-09-001-Rev. 0	9
2	Material requisition for carbon steel coated line pipes	11-0290-02-07-06-001-Rev. 0	9
3	Specification for Bare line Pipes	11-0290-02-07-02-003-Rev. 0	41
4	Specifications For 3LPE Coatings for Line Pipes	11-0290-02-07-02-004-Rev. 0	29
5	Quality Assurance Plan / Inspection Levels	11-0290-02-07-10-001-Rev. 0	5
6	Check List	FORM-A	1
7	Proposed Pipe Mills' past track record for supply of line pipes of same or higher in terms of diameter, wall thickness and grade in the last seven years	FORM-B	1
8	Compliance Statement	FORM-C	3



VOLUME II OF II (TECHNICAL)
BIDDING DOCUMENT FOR CARBON
STEEL COATED LINE PIPES

DOCUMENT NO.

REV

11/0290/WGI/GGL/01-R0

0

SHEET 2 OF 2



GAIL GAS LIMITED
CITY GAS DISTRIBUTION PROJECT



VOLUME II OF II (TECHNICAL)
BIDDING DOCUMENT FOR CARBON STEEL
COATED LINE PIPES

CLIENT JOB NO.

-

TOTAL SHEETS

09

DOCUMENT NO

11

0290

02

07

09

001



REV	DATE	DESCRIPTION	PREP	CHK	APPR
0	04/11/09	ISSUED FOR CLIENT COMMENTS	MH	SB	SB
A	29/10/09	ISSUED FOR IDC	MH	SB	SB

CONTENTS

1 INTRODUCTION..... 3

2 SCOPE..... 3

3 DETAILS OF LINE PIPES 5

4 WORKS ASSOCIATED WITH EXTERNAL COATING OF LINE PIPES/ SUPPLY OF COATED LINE PIPES (OPTION-2 & OPTION-3)..... 6

	SCOPE OF WORK FOR PROCUREMENT OF COATED LINE PIPES	DOCUMENT NO.	REV
		11-0290-02-07-09-001	0

1 INTRODUCTION

M/s Gail Gas Limited intends to install a pipeline for city gas distribution project. The pipelines shall be used for transportation of Natural Gas/RLNG/PNG.

2 SCOPE

The scope of works and supply, under this requisition is covered under three options as detailed in the requisition and includes the following:

• OPTION-1 (Supply of Bare Line Pipes):

Manufacture and supply of pipes as per Table - 1 bare line pipes as per specification nos. 11-0290-02-07-02-003 Rev.A, as applicable. Bare Pipes shall be supplied on FOT (Ex- works basis) in case the pipes are of domestic origin. Pipes shall be supplied on FOB basis in case the pipes are from imported origin.

• OPTION-2 (Coating and Transportation):

Taking over and handling of line pipes from pipe supplier on Port/ FOT basis, inland transportation to coating yard/ storage yards, application of 3-layer side extruded polyethylene external corrosion protection coating on bare linepipes as per specification no. 11-0290-02-07-02-004 Rev A, transportation of bare and coated pipes to designated storage yards. Arrangement & maintenance of Storage Yards as detailed below under "Table -1 for Option-2 and Option-3".

• OPTION-3 (Supply of Coated Linepipes):

Carrying out all works associated with manufacture and supply of line pipes, application of 3-layer side extruded polyethylene external corrosion protection coating as per specification no11-0226E-01-07-02-004 and transportation of bare and coated pipes to designated storage yards. Arrangement & maintenance of Storage Yards as detailed below under "Table -1 Option-2 and Option-3".

• ADDITIONAL WORKS FOR OPTION-2 AND OPTION-3:

- Handling & stacking of bare and coated linepipes at Storage yards.
- Management and Maintenance of Storage Yards.
- Handing over of bare/ coated pipes to the Gail Gas store.

The description in the subsequent sections pertains to bare pipes & external coating and associated works. The requirements shall be as applicable to the respective bidders as per their offer.

Table-1

1.1 STORAGE YARD/DELIVERY POINT:- WARE HOUSE AT SONIPAT FOR MEERUT CITY

Supply of API 5L PSL-2 Carbon Steel line pipes manufactured & conforming to spec. no. 11-0290-02-07-02-003 and duly coated with 3Layer Polyethylene (External) as per specification nos. 11-0290-02-07-02-004 respectively, as per following details:

Item No.	Quantity (Metre)	Specified Outside Diameter, mm(inch) & Grade	Specified Wall Thickness (mm)	Item
1	4000	273 (10") Grade X-52	6.4	EW / SEAMLESS Coated Line pipes
2	13000	219.1 (8") Grade X-42	6.4	EW / SEAMLESS Coated Line pipes
3	21000	168.3 (6") Grade X-42	6.4	EW / SEAMLESS Coated Line pipes



**SCOPE OF WORK FOR
PROCUREMENT OF COATED LINE
PIPES**

DOCUMENT NO.

11-0290-02-07-09-001

REV

0

SHEET 3 OF 9

Table-1

1.1 STORAGE YARD/DELIVERY POINT:- WARE HOUSE AT SONIPAT FOR MEERUT CITY

Supply of API 5L PSL-2 Carbon Steel line pipes manufactured & conforming to spec. no. 11-0290-02-07-02-003 and duly coated with 3Layer Polyethylene (External) as per specification nos. 11-0290-02-07-02-004 respectively, as per following details:

Item No.	Quantity (Metre)	Specified Outside Diameter, mm(inch) & Grade	Specified Wall Thickness (mm)	Item
4	7000	114.3 (4") Grade X-42	6.4	EW / SEAMLESS Coated Line pipes

Table-1

1.2 STORAGE YARD/DELIVERY POINT:- WARE HOUSE AT SONIPAT CITY

Supply of API 5L PSL-2 Carbon Steel line pipes manufactured & conforming to spec. no. 11-0290-02-07-02-003 and duly coated with 3Layer Polyethylene (External) as per specification nos. 11-0290-02-07-02-004 respectively, as per following details:

Item No.	Quantity (Metre)	Specified Outside Diameter, mm(inch) & Grade	Specified Wall Thickness (mm)	Item
1	13000	273 (10") Grade X-52	6.4	EW / SEAMLESS Coated Line pipes
2	2000	114.3 (4") Grade X-42	6.4	EW / SEAMLESS Coated Line pipes

Table-1

1.3 STORAGE YARD/DELIVERY POINT:- WARE HOUSE AT KOTA CITY

Supply of API 5L PSL-2 Carbon Steel line pipes manufactured & conforming to spec. no. 11-0290-02-07-02-003 and duly coated with 3Layer Polyethylene (External) as per specification nos. 11-0290-02-07-02-004 respectively, as per following details:

Item No.	Quantity (Metre)	Specified Outside Diameter, mm(inch) & Grade	Specified Wall Thickness (mm)	Item
1	17000	273 (10") Grade X-52	6.4	EW / SEAMLESS Coated Line pipes
2	14000	219.1 (8") Grade X-42	6.4	EW / SEAMLESS Coated Line pipes
3	1000	168.3 (6") Grade X-42	6.4	EW / SEAMLESS Coated Line pipes



**SCOPE OF WORK FOR
PROCUREMENT OF COATED LINE
PIPES**

DOCUMENT NO.

11-0290-02-07-09-001

REV

0

SHEET 4 OF 9

Table-1

1.3 STORAGE YARD/DELIVERY POINT:- WARE HOUSE AT KOTA CITY

Supply of API 5L PSL-2 Carbon Steel line pipes manufactured & conforming to spec. no. 11-0290-02-07-02-003 and duly coated with 3Layer Polyethylene (External) as per specification nos. 11-0290-02-07-02-004 respectively, as per following details:

Item No.	Quantity (Metre)	Specified Outside Diameter, mm(inch) & Grade	Specified Wall Thickness (mm)	Item
4	2000	114.3 (4") Grade X-42	6.4	EW / SEAMLESS Coated Line pipes

Table-1

1.4 STORAGE YARD/DELIVERY POINT:- WARE HOUSE AT DEWAS CITY

Supply of API 5L PSL-2 Carbon Steel line pipes manufactured & conforming to spec. no. 11-0290-02-07-02-003 and duly coated with 3Layer Polyethylene (External) as per specification nos. 11-0290-02-07-02-004 respectively, as per following details:

Item No.	Quantity (Metre)	Specified Outside Diameter, mm(inch) & Grade	Specified Wall Thickness (mm)	Item
1	1000	273 (10") Grade X-52	6.4	EW / SEAMLESS Coated Line pipes
2	3000	219.1 (8") Grade X-42	6.4	EW / SEAMLESS Coated Line pipes
3	13000	168.3 (6") Grade X-42	6.4	EW / SEAMLESS Coated Line pipes
4	9000	114.3 (4") Grade X-42	6.4	EW / SEAMLESS Coated Line pipes

3 DETAILS OF LINE PIPES

The line pipes shall be API 5L Gr. X-52 PSL 2 & API 5L Gr. X-42 PSL-2 and following are quantities of all line pipes covered under this requisition in Table-2 & 3:-



**SCOPE OF WORK FOR
PROCUREMENT OF COATED LINE
PIPES**

DOCUMENT NO.

REV

11-0290-02-07-09-001

0

SHEET 5 OF 9

Table-2

Supply of API 5L Grade X-52 PSL-2 Carbon Steel line pipes manufactured & conforming to spec. no. 11-0290-02-07-02-003 Rev.A and duly coated with 3Layer Polyethylene (External) as per specification nos. 11-0290-02-07-02-004 Rev.A respectively, as per following details:

Item No.	Quantity (Metre)	Specified Outside Diameter, mm(inch)	Specified Wall Thickness (mm)	Option -1	Option -2	Option -3
1	35000	273 (10"), EW/SMLS	6.4	Bare	Coating	Coated

Table-3

Supply of API 5L Grade X-42 PSL-2 Carbon Steel line pipes manufactured & conforming to spec. no. 11-0290-02-07-02-003 Rev.A and duly coated with 3Layer Polyethylene (External) as per specification nos. 11-0290-02-07-02-004 Rev.A respectively, as per following details:

Item No.	Quantity (Metre)	Specified Outside Diameter, mm(inch)	Specified Wall Thickness (mm)	Option -1	Option -2	Option -3
1	30000	219.1 (8") EW / SMLS	6.4	Bare	Coating	Coated
2	35000	168.3 (6") EW / SMLS	6.4	Bare	Coating	Coated
3	20000	114.3 (4") EW/SMLS	6.4	Bare	Coating	Coated

4 WORKS ASSOCIATED WITH EXTERNAL COATING OF LINE PIPES/ SUPPLY OF COATED LINE PIPES (OPTION 2 & OPTION 3)

The Bidder's scope of work for the work tendered shall generally include, but not limited to, the following:

- 4.1 Making necessary arrangement in Bidder's existing coating yard for the work, as applicable.
- 4.2 "Receiving and taking over" of line pipes as defined below. All inland/marine transportation to coating yard, unloading, handling, stacking/storing of line pipes within the coating yard(s).

In case bare line pipe supply is of imported origin, the Contractor shall "receive and take-over" the line pipes at Indian Port of entry. The Contractor shall take over the line pipes from the vessel & shall be responsible for port clearances, Custom clearances, stevedoring, Liaisoning, port fees, easements, warehousing, wharf-age, demurrage, handling, unloading/loading as required including the payment of all fees, charges, insurance survey etc. lodging of claims if any, submission of all necessary documents like exchange control copy & other documents required by Company without which no payment shall be made to the Contractor. All charges to get the consignment cleared shall be on account of the Contractor except payment of the Custom Duty which shall be paid by the Company directly in the name of custom department. Company shall pay only the custom duty. All other payments, costs, fees, expenses shall be borne by the Contractor.

In case bare line pipe supply is of domestic origin, the coating Contractor shall receive and take over the pipes ex-pipe mill(s) on FOT basis. Contractor shall take only defect free pipes from pipe



SCOPE OF WORK FOR PROCUREMENT OF COATED LINE PIPES

DOCUMENT NO.

REV

11-0290-02-07-09-001

0

SHEET 6 OF 9

manufacturer. Pipe manufacturer shall repair the defect found at the time of handing over of pipes to coating Contractor. Any defect found after taking over shall be repaired by the Coating Contractor at no cost to Company.

The Contractor shall arrange and provide required number of trailers/trucks for transportation of bare pipes for imported as well as domestic origin to the coating yard(s) as part of Contractor's scope of work.

4.3 Repair of defects on pipes noticed and recorded at the time of taking over for pipes of imported origin. These defects shall be repaired by Coating Contractor and compensation for such repair works shall be as per the rates set forth in the requisition. All scrap generated due to such repairs shall be returned to Company/Company representative. This clause shall be applicable only for pipes of imported origin.

4.4 Inspection of bare pipes at place of issue.

4.5 Repair and/or cutting out (including ultrasonic inspection, if required) of all pipe defects occurring after taking over and till the time bare / coated line pipes are handed over to Company / Installation Agency. All costs towards such repairs shall be to Contractor's account.

All scrap generated during repair of defects shall be returned/ disposed off as per the instructions of Company's representative.

4.6 For pipes where cutting out involves more than 25 mm from ends during repair of damages as mentioned above, non-destructive examination shall be carried out at pipe ends as per specification for pipes including supply of all equipment and taking prior approval from Company for the agency engaged for carrying out such works.

4.7 Supply of all coating materials as per specification no. 11-0290-02-07-02-004 for carrying out 3 layer polyethylene coating.

4.8 Handling, transportation, loading/ unloading and stacking/ storing of coated line pipes within the coating yard.

4.9 Handling, loading and transportation of coated line pipes from contractor's coating yard to Storage Yards including arrangement & provision of required number of trailers/trucks for transportation, all unloading, handling and stacking of coated line pipes at Storage Yards.

4.10 Cleaning and surface preparation of pipes, application of 3 layer side extruded polyethylene coating on bare line pipes, carrying out inspection and testing, repairing of coating defects, re-testing, any cutting of pipes for the purpose of PQT or regular production testing, carrying out re-bevelling and all associated works after cutting etc. and carrying out all coating works as per specification no. 11-0290-02-07-02-004. Application shall also include coating of pipes of non-standard lengths obtained in case of cutting of bare pipes necessitated for removal of dents/defects.

4.11 Materials to be supplied by Bidder

Bidder shall procure and supply in sequence and at appropriate time, all corrosion coating materials, repair materials, all accessories, consumables and utilities required for completion of works. The rates quoted for the execution of the work shall be inclusive of supply of these materials. All materials supplied shall be strictly in accordance with the requirements of relevant applicable Company specifications enclosed.

Materials to be supplied shall include, but not limited to, the following:

- a. All materials and equipment required for repair re-bevelling and / or cutting out defects of bare pipes
- b. All consumables, equipment required for surface cleaning / preparation etc.

	<p align="center">SCOPE OF WORK FOR PROCUREMENT OF COATED LINE PIPES</p>	DOCUMENT NO.	REV
		11-0290-02-07-09-001	0
		SHEET 7 OF 9	

- c. All external coating materials and other materials, equipment, consumables as required for coating.
- d. All materials and equipment required for conducting all types of inspection and tests including non-destructive testing of pipes after rebeveling/ grinding.
- e. All materials and equipment required for repairing of defects of coated pipes and thereafter re-testing.
- f. All equipment, tools, tackles, trucks/ trailers, devices required for loading, transportation, hauling, handling, unloading, stacking, and storage of bare/ coated pipes.
- g. Any other items not mentioned above but required for timely completion of work in all respect.

4.12 Other Requirements

4.12.1 The coating plant, equipment, machinery and other facilities shall be in good operating condition to meet the job requirement of quality and production. Worn out or improvised plant are not acceptable. The coating plant(s) for the work shall be of size and capacity that shall be suitable for the scale of work, production rate, time schedule specified elsewhere in the tender document.

4.12.2 All external coating materials shall be as per specification no. 11-0290-02-07-02-004. The bidder's proposed coating raw material supplier(s) shall be manufacturer of the materials meant for the three layer side extruded polyethylene coating of pipes. He must have manufactured and supplied the offered grades of materials within the last seven years reckoned from the bid due date. Bidder's offer shall be unconditional irrespective of the finally qualified raw material manufacturer(s).

4.12.3 Bidder shall, at his own responsibility and cost, provide and prepare all necessary area for the storage of pipes and all other materials for coating yard, stock piling, and other temporary installation. Bidder shall provide servitude agreements as required with the relevant authorities and on work completion to clean, restore and pay settlements and claim for damages.

4.12.4 It is mandatory for the Bidder to provide all testing instruments/ equipment required for qualification, pre production and regular production testing with adequate inventory to carry out tests required within the coating yard. No outside testing is acceptable for this purpose.

4.12.5 Bidder shall, at his own responsibility and cost, provide water and power supply and other utilities, obtain permit regarding access roads and other permits required for the execution of works conforming to all the requirements of the governing authorities.

4.12.6 All handling, loading, unloading, stacking/storing shall be done in such a manner as to minimise mechanical damages & corrosion and as per the procedure approved by the Company.

- All handling shall be done with slings or padded hooks.
- Trailers shall be cleaned of debris or any other substance that might damage the pipe
- Suitable timber and other dunnage shall be used to protect the pipes against the damage during transit.
- Loading shall be done in accordance with API RP 5L1 and procedure approved by the Company.
- Finished pipe to be stored for a significant period of time in the coating yard in a manner to prevent corrosion and damages to the coating.

4.12.7 A coating specialist shall be made available during entire duration of coating works.

	SCOPE OF WORK FOR PROCUREMENT OF COATED LINE PIPES	DOCUMENT NO.	REV
		11-0290-02-07-09-001	0
		SHEET 8 OF 9	

- 4.12.8 Coating wastage generated due to standard cut backs on external coating shall be the property of the Bidder.
- 4.12.9 Any other works not listed specifically herein but required to be carried out by the Bidder in order to complete the job in all respects, shall also form a part of Bidder's scope.

	<p align="center">SCOPE OF WORK FOR PROCUREMENT OF COATED LINE PIPES</p>	<p align="center">DOCUMENT NO.</p>	<p align="center">REV</p>
		<p align="center">11-0290-02-07-09-001</p>	<p align="center">0</p>
		<p>SHEET 9 OF 9</p>	

JP KENNY



GAIL GAS LIMITED
CITY GAS DISTRIBUTION PROJECT



**MATERIAL REQUISITION FOR CARBON STEEL
BARE / COATING / COATED LINE PIPES**

CLIENT JOB NO.

TOTAL SHEETS

9

DOCUMENT NO

11

0290

02

07

06

001



0	4.11.09	ISSUED FOR CLIENT COMMENTS	MH	SB	SB
A	29.10.09	ISSUED FOR IDC	MH	SB	SB
REV.	DATE	DESCRIPTION	PREP	CHKD	APPD

CONTENTS

1 SCOPE OF SUPPLY (SOS)3

1.1 GENERAL.....3

1.2 MATERIAL DELIVERY REQUIREMENTS.....3

1.3 LINEPIPE.....5

2 SPECIFIC TECHNICAL REQUIREMENTS.....6

3 LIST OF ATTACHMENTS7

4 DOCUMENTS & VENDOR DATA REQUIREMENTS LIST8

	MATERIAL REQUISITION FOR CARBON STEEL BARE / COATING / COATED LINE PIPES	DOCUMENT NO.	REV
		11-0290-02-07-06-001	0
		SHEET 2 OF 9	

1 SCOPE OF SUPPLY (SOS)

1.1 General

This requisition covers the scope of supply of coated line pipes, for use on city gas distribution pipeline Project for natural Gas/ R-LNG services.

The scope of supply includes the manufacture, inspection, testing, preparation for shipment and documentation requirements of these items in accordance with the requirements of this Requisition and the Vendor Drawing / Data Requirements List (VDR) and those detailed in Specification.

1.2 Material Delivery Requirements

The finished materials are to be delivered by the Supplier at the nominated delivery point, fixed by the Purchaser/ Purchaser Representative.

The Supplier shall be responsible for all handling and transportation between his production plant and the Purchasers nominated delivery point at Sonipat, Kota and Dewas in accordance with Table-1 and the specification.

Table-1

1.1 STORAGE YARD/DELIVERY POINT:- WARE HOUSE AT SONIPAT FOR MEERUT CITY

Supply of API 5L PSL-2 Carbon Steel line pipes manufactured & conforming to spec. no. 11-0290-02-07-02-003 and duly coated with 3Layer Polyethylene (External) as per specification nos. 11-0290-02-07-02-004 respectively, as per following details:

Item No.	Quantity (Metre)	Specified Outside Diameter, mm(inch) & Grade	Specified Wall Thickness (mm)	Item
1	4000	273 (10") Grade X-52	6.4	EW / SEAMLESS Coated Line pipes
2	13000	219.1 (8") Grade X-42	6.4	EW / SEAMLESS Coated Line pipes
3	21000	168.3 (6") Grade X-42	6.4	EW / SEAMLESS Coated Line pipes
4	7000	114.3 (4") Grade X-42	6.4	EW / SEAMLESS Coated Line pipes

JP KENNY



**MATERIAL REQUISITION FOR
CARBON STEEL BARE / COATING /
COATED LINE PIPES**

DOCUMENT NO.

11-0290-02-07-06-001

REV

0

SHEET 3 OF 9

Page 14 of 100

Table-1

1.2 STORAGE YARD/DELIVERY POINT:- WARE HOUSE AT SONIPAT CITY

Supply of API 5L PSL-2 Carbon Steel line pipes manufactured & conforming to spec. no. 11-0290-02-07-02-003 and duly coated with 3Layer Polyethylene (External) as per specification nos. 11-0290-02-07-02-004 respectively, as per following details:

Item No.	Quantity (Metre)	Specified Outside Diameter, mm(inch) & Grade	Specified Wall Thickness (mm)	Item
1	13000	273 (10") Grade X-52	6.4	EW / SEAMLESS Coated Line pipes
2	2000	114.3 (4") Grade X-42	6.4	EW / SEAMLESS Coated Line pipes

Table-1

1.3 STORAGE YARD/DELIVERY POINT:- WARE HOUSE AT KOTA CITY

Supply of API 5L PSL-2 Carbon Steel line pipes manufactured & conforming to spec. no. 11-0290-02-07-02-003 and duly coated with 3Layer Polyethylene (External) as per specification nos. 11-0290-02-07-02-004 respectively, as per following details:

Item No.	Quantity (Metre)	Specified Outside Diameter, mm(inch) & Grade	Specified Wall Thickness (mm)	Item
1	17000	273 (10") Grade X-52	6.4	EW / SEAMLESS Coated Line pipes
2	14000	219.1 (8") Grade X-42	6.4	EW / SEAMLESS Coated Line pipes
3	1000	168.3 (6") Grade X-42	6.4	EW / SEAMLESS Coated Line pipes
4	2000	114.3 (4") Grade X-42	6.4	EW / SEAMLESS Coated Line pipes



**MATERIAL REQUISITION FOR
CARBON STEEL BARE / COATING /
COATED LINE PIPES**

DOCUMENT NO.

11-0290-02-07-06-001

REV

0

SHEET 4 OF 9

Table-1**1.4 STORAGE YARD/DELIVERY POINT:- WARE HOUSE AT DEWAS CITY**

Supply of API 5L PSL-2 Carbon Steel line pipes manufactured & conforming to spec. no. 11-0290-02-07-02-003 and duly coated with 3Layer Polyethylene (External) as per specification nos. 11-0290-02-07-02-004 respectively, as per following details:

Item No.	Quantity (Metre)	Specified Outside Diameter, mm(inch) & Grade	Specified Wall Thickness (mm)	Item
1	1000	273 (10") Grade X-52	6.4	EW / SEAMLESS Coated Line pipes
2	3000	219.1 (8") Grade X-42	6.4	EW / SEAMLESS Coated Line pipes
3	13000	168.3 (6") Grade X-42	6.4	EW / SEAMLESS Coated Line pipes
4	9000	114.3 (4") Grade X-42	6.4	EW / SEAMLESS Coated Line pipes

1.3 Linepipe

The line pipes shall be API 5L Gr. X-52 & X-42 PSL-2 and following are quantities of all line pipes covered under this requisition in Table- 2 & 3

Table-2

Supply of API 5L Grade X-52 PSL-2 Carbon Steel line pipes manufactured & conforming to spec. no. 11-0290-02-07-02-003 Rev.A and duly coated with 3Layer Polyethylene (External) as per specification nos. 11-0290-02-07-02-004 Rev.A respectively, as per following details:

Item No.	Quantity (Metre)	Specified Outside Diameter, mm(inch)	Specified Wall Thickness (mm)	Option -1	Option -2	Option -3
1	35000	273 (10"), EW/SMLS	6.4	Bare	Coating	Coated

Table-3

Supply of API 5L Grade X-42 PSL-2 Carbon Steel line pipes manufactured & conforming to spec. no. 11-0290-02-07-02-003 Rev.A and duly coated with 3Layer Polyethylene (External) as per specification nos. 11-0290-02-07-02-004 Rev.A respectively, as per following details:

Item No.	Quantity (Metre)	Specified Outside Diameter,	Specified Wall Thickness	Option -1	Option -2	Option -3

JP KENNY

**MATERIAL REQUISITION FOR
CARBON STEEL BARE / COATING /
COATED LINE PIPES**

DOCUMENT NO.

11-0290-02-07-06-001

REV

0

SHEET 5 OF 9**Page 16 of 100**

		mm(inch)	(mm)			
1	30000	219.1 (8") EW / SMLS	6.4	Bare	Coating	Coated
2	35000	168.3 (6") EW / SMLS	6.4	Bare	Coating	Coated
3	20000	114.3 (4") EW/SMLS	6.4	Bare	Coating	Coated

2 SPECIFIC TECHNICAL REQUIREMENTS

The manufacture and supply of the line pipe are to be generally in accordance with Bid Document.

In addition to the requirements of the BEC, the manufacturer is required to supply the following documentation in support of the bid:

- a. Inspection and Test Plan for Bare Line Pipes.
- b. Inspection and test plan for Coating Works.
- c. Process of manufacture of Bare Line Pipes.
- d. Process of Application of 3 Layer PE Coating.
- e. Quality Surveillance manual.
- f. Delivery schedule.
- g. Valid API Certificate for the proposed mill(s) for manufacturing of Line Pipes.
- h. Quality Surveillance for Coating Works

REMARKS/COMMENTS

1. GENERAL NOTES

VENDOR'S COMPLIANCE

Vendor must include the following statement in his bid:

We certify that our bid is fully complying with your enquiry dated....., and referenced.....,

Compliance with this material requisition in any instance shall not relieve the Vendor of his responsibility to meet the specified performance.

2. COMPLIANCE WITH SPECIFICATION

The VENDOR shall be completely responsible for the design, materials, fabrication, coating, testing, inspection, preparation for shipment, transport, delivery to nominated delivery points strictly in accordance with the Material Requisition and all attachments thereto.

3. INSPECTION

Inspection shall be performed by Third Party Inspection agency (TPI) appointed by CLIENT/CONSULTANT as per QAP submitted by the Bidder on receipt of order & approved by CLIENT / CONSULTANT.

4. MATERIAL HANDLING & TRANSPORTATION

Handling and transportation of coated line pipes to this specification shall meet the requirements of API RP 5L1 or API RP 5LW as applicable,

	MATERIAL REQUISITION FOR CARBON STEEL BARE / COATING / COATED LINE PIPES	DOCUMENT NO.	REV
		11-0290-02-07-06-001	0
		SHEET 6 OF 9	

Special attention shall be paid for loading/ unloading and handling works so as to prevent damage of pipe body and polyethylene coating.

Bevel protectors shall be removed before the pipe travels through the coating plant and replaced with same or new caps after the pipe is coated.

Transportation of line pipe by truck to this specification shall comply with the laws and regulations of authorities having the jurisdiction over transportation of goods in all jurisdictions between the point of loading and location of destination. Loading and handling procedure shall comply with the requirements of API RP 5L1.

Wooden dunnage shall be laid at approximately same interval. Soft material such as rubber sheet should preferably be applied between pipe and wooden dunnage.

When transporting exterior coated pipe, rubber padding shall be used to separate each joint from contact with adjacent joints and with the surface of the truck. Reasonable care shall be used in handling to ensure that the pipe reaches its destination with the coating intact and undamaged.

Pipe shall be handled in a manner to prevent damage to the pipe and its coated surfaces.

End hooks suitably radiused and lined with plastic or similar approved material or a forklift with suitably padded forks shall be used to pick up pipe. A spreader bar shall be used between lifting lines. During handling, the pipe shall be prevented from impacts or jars. Vendor representative shall be advised of any pipe suffering impact or jars.

Lifting equipment shall be CLIENT / CONSULTANT approved. Wire ropes shall not be used in direct contact to lift pipes.

5 LIST OF ATTACHMENTS

The table here below lists the documents & Codes, which are integral part of this Material Requisition. The applicable revision index of each document is mentioned below the current Material Requisition revision index.

ATTACHMENT NO.	DOCUMENTS DESCRIPTION	DOCUMENTS NO.	NO. OF PAGES
1	Specification for bare (ERW) & Seamless line pipes	11-0290-02-07-02-003	41
2	Specifications For 3LPE Coatings for Line Pipes	11-0290-02-07-02-004	29
3	Quality Assurance Plan / Inspection Levels	11-0290-02-07-10-001	5
4	Check List	FORM-A	1
5	Proposed Pipe Mills' past track record for supply of line pipes of same or higher in terms of diameter, wall thickness and grade in the last seven years	FORM-B	1
6	Compliance Statement	FORM-C	3

	MATERIAL REQUISITION FOR CARBON STEEL BARE / COATING / COATED LINE PIPES	DOCUMENT NO.	REV
		11-0290-02-07-06-001	0
		SHEET 7 OF 9	

6 DOCUMENTS & VENDOR DATA REQUIREMENTS LIST

(VDRL)

The table hereunder specifies the quantities and the nature of the documents to be submitted by the Vendor / manufacturer to the ENGINEER. VENDOR shall supply the documentation as listed under table of this Material Requisition. All documents shall be supplied in English language.

The documents required at the inquiry stage and to be included in the bid are listed under column A.

The documents required after award of the AGREEMENT and subject to the written approval of the ENGINEER are listed under column B.

The final and certified documents are listed under column C.

Any document, even if preliminary, shall be binding and therefore duly identified and signed by the CONTRACTOR. It shall bear the Engineer's Project reference, the Material Requisition number and the identification number.

THE DOCUMENTS ARE FULLY PART OF THE SUPPLY WHICH SHALL BE COMPLETE ONLY IF AND WHEN THE DOCUMENTS COMPLYING FULLY WITH THE MATERIAL REQUISITION REQUIREMENTS ARE RECEIVED BY THE ENGINEER.

Item	Documents and Data	A	B		C	
		Number of Copies	Number of Copies	Required Date	Number of Copies	Required Date
1	Drawing / Data submittal list/ Schedule	3	6	2 weeks + Monthly	6	2 weeks after Approval
2	Manufacturing Equipment List, Testing Facility, Manufacturing Procedure, test and Delivery Schedule (Item wise)	3	6	2 weeks + Monthly	6	2 weeks
3	Progress Report		6	2 weeks + Monthly		
4	Catalogues / Reference	3				
5	Code Compliance Certificates, ISO:9000 or other QAM	3	6	3 Weeks	6	2 weeks after Approval
6	QA/QC Programme	3	6	2 weeks	6	2 weeks after Approval
7	Inspection and Test Procedures	3	6	4 Weeks	6	2 weeks after Approval + With Final

	<p align="center">MATERIAL REQUISITION FOR CARBON STEEL BARE / COATING / COATED LINE PIPES</p>	DOCUMENT NO.	REV
		11-0290-02-07-06-001	0
		SHEET 8 OF 9	

Item	Documents and Data	A	B		C	
		Number of Copies	Number of Copies	Required Date	Number of Copies	Required Date
						Technical File
8	Material & Product Certifications		6	1 week after Test	6	With Final Technical File
9	Packing / Shipping List / Weight and Dimensions.		6	8 weeks	6	2 weeks before Shipping
10	Final Technical File				8	With Shipping

NOTES

- 1) Durations in column B (Required date) are weeks after Purchase Order date (=T0)
- 2) Durations in column C (Required date) are weeks after document approval.
Due date of each document may be proposed.
- 3) Latest submittal time for:
 - Test procedure : 2 weeks before test
 - Test report : 2 weeks after test
- 4) Final technical file shall be supplied in hard copy as indicated, and in Electronic format on two (2) CD-ROMs

	MATERIAL REQUISITION FOR CARBON STEEL BARE / COATING / COATED LINE PIPES	DOCUMENT NO.	REV
		11-0290-02-07-06-001	0
		SHEET 9 OF 9	



GAIL GAS LIMITED
CITY GAS DISTRIBUTION PROJECT



SPECIFICATION FOR BARE (EW) & SEAMLESS LINE PIPES	CLIENT JOB NO.	-
	TOTAL SHEETS	41

DOCUMENT NO	11	0290	02	07	02	003
--------------------	----	------	----	----	----	-----

--	--	--	--	--	--

0	4.11.09	ISSUED FOR CLIENT COMMENTS	MH	SB	SB
A	29.10.09	ISSUED FOR IDC	MH	SB	SB
REV	DATE	DESCRIPTION	PREP	CHK	APPR

TECHNICAL SPECIFICATION FOR ERW LINEPIPE

CONTENTS

1	INTRODUCTION.....	3
2	CONFORMITY	3
3	NORMATIVE REFERENCES	3
4	TERMS AND DEFINITIONS	4
5	SYMBOLS & ABBREVIATED TERMS	4
6	PIPE GRADE, STEEL GRADE & DELIVERY CONDITION	4
7	INFORMATION TO BE SUPPLIED BY THE PURCHASER	4
8	MANUFACTURING	4
9	ACCEPTANCE CRITERIA	6
10	INSPECTION	13
11	MARKING	19
12	COATING AND THREAD PROTECTORS.....	19
13	RETENTION OF RECORDS	19
14	PIPE LOADING	21
15	INSPECTION OF FIELD TEST AND WARRANTY	21
	APPENDIX I: MANUFACTURING PROCEDURE SPECIFICATION.....	22
	APPENDIX II (NEW): FIRST DAY PRODUCTION TEST.....	24
	ANNEXURE C.....	26
	ANNEXURE E.....	27

	SPECIFICATION FOR BARE (ERW) & SEAMLESS LINE PIPES	DOCUMENT NO.	REV
		11-0290-02-07-02-003	0
		SHEET 2 OF 41	

1 INTRODUCTION

1.1 SCOPE

This specification establishes requirements for the manufacture of PSL 2 seamless & welded steel pipes for use in pipeline transportation systems in petroleum & natural gas industries.

This specification is not applicable to cast pipes.

This specification establishes the minimum requirements for the manufacture of longitudinal seam electric welded steel line pipe in accordance with the requirements of API (American Petroleum Institute) Specification 5L, Forty fourth edition and makes restrictive amendments to API Spec 5L. Unless modified and/or deleted by this specification, the requirements of API Spec. 5L shall remain applicable.

The sections, paragraphs and appendices contained herein have the same numbering as that of API Spec 5L, in order to facilitate reference. Additional requirements, which are not specified in API Spec 5L, have also been numbered and marked as "(New)".

COVERAGE:

The coverage by this specification is limited to line pipe to be used in onshore pipelines transporting non-sour hydrocarbons in liquid or gaseous phase.

The Manufacturer shall have a valid license to use API Monogram in accordance with the requirements of API Spec 5L, Forty fourth edition.

1.2 PRODUCT SPECIFICATION LEVEL (PSL)

(New)

Line pipe supplied to this specification shall conform to Product Specification Level PSL 2.

1.3 GRADES

(New)

This specification is applicable to PSL 2 line pipes of grade B through X80.

1.4 DIMENSIONS

(New)

This specification shall be applied to line pipe of size 4 ½ through 24 (both sizes included).

2 CONFORMITY

2.1 UNITS OF MEASUREMENT

Data is expressed in both SI units and USC units. For a specific order item, unless otherwise stated, only one system of units shall be used, without combining data expressed in the other system.

2.2 ROUNDING

In this International Standard, to determine conformance with the specified requirements, observed or calculated values shall be rounded to the nearest unit in the last right-hand place of figures used in expressing the limiting value, in accordance with ISO 31-0:1992, Annex B, Rule A.

3 NORMATIVE REFERENCES

The latest editions (editions enforce at the time of issue of enquiry) of codes/standards as mentioned in API 5L 44th edition shall be used.



**SPECIFICATION FOR BARE (ERW) &
SEAMLESS LINE PIPES**

DOCUMENT NO.

11-0290-02-07-02-003

REV

0

SHEET 3 OF 41

Page 23 of 100

4 TERMS AND DEFINITIONS

For this specification the following definitions shall apply:

OWNER	- Gail Gas Limited
CONSULTANT	- Wood Group Engineering India (P) Limited
CONTRACTOR	- The Company named as such in the deed.
SHALL/MUST/ISTO BE	- A mandatory requirement
SHOULD	- A non-mandatory requirement, advisory or recently Amended

5 SYMBOLS & ABBREVIATED TERMS

Symbols and abbreviated terms shall be as defined in API 5L, 44th edition.

6 PIPE GRADE, STEEL GRADE & DELIVERY CONDITION

6.1 PIPE GRADE AND STEEL GRADE

6.1.2 The pipe grade for PSL 2 pipe shall be according to Table 1 of API 5L, 44th Edition and as mentioned elsewhere in the bid document.

6.2 DELIVERY CONDITION

6.2.2 For PSL 2 pipes, the delivery condition shall be in accordance with the purchase order as specified elsewhere in the bid document.

7 INFORMATION TO BE SUPPLIED BY THE PURCHASER

7.1 GENERAL INFORMATION

The purchase order shall include the following information:

- a) Quantity (e.g. total mass or total length of pipe);
- b) PSL (1 or 2)
- c) Type of pipe (Refer table 2 or 3 of API 5L, 44th edition)
- d) Steel grade (API 5L X42 PSL-2)
- e) Outside diameter & wall thickness Length and type of length Confirmation of applicability of individual annexes.

8 MANUFACTURING

8.1 PROCESS OF MANUFACTURE

The pipes shall be manufactured in accordance with the applicable requirements and limitations given in Table 2 & 3 of API 5L, 44th edition.

Following paragraphs of API Spec 5L shall be applicable to the line pipe manufactured as per this specification:

Welding Process : Electric Welding as per para 4.16.

	SPECIFICATION FOR BARE (ERW) & SEAMLESS LINE PIPES	DOCUMENT NO.	REV
		11-0290-02-07-02-003	0
		SHEET 4 OF 41	

Type of Pipe : High frequency Electric Welded Pipe as per para 4.18.
 Type of Seam Weld : Electric Welding as per para 4.16.

A Manufacturing Procedure Specification (MPS) as described in Appendix I of this specification shall be prepared and submitted to Purchaser for approval prior to start of production.

Third party inspection shall be carried out at steel mill to carry out the test specified above per heat.

(New) PSL 2 ELECTRIC WELDED PIPE

Electric welding shall be performed with a minimum welder frequency of 200 kHz. The welding system shall have an integrated control in which following data as a minimum shall be monitored:

- . Time
- . Welding speed
- . Current and Voltage
- . Heat treatment temperature

The weld seam and the entire heat affected zone (HAZ) shall be heat treated so as to stimulate a normalizing heat treatment in order to control the structure so that no untempered martensite remain in the weld seam and the HAZ, and the mechanical properties of heat treated zone approximates that of the parent metal.

8.2 PROCESSES REQUIRING VALIDATION

Final operations performed during pipe manufacturing that affect attribute compliance as required in this International Standard (except chemical composition and dimensions) shall have their processes validated.

The following processes require validation.

- for seamless, as-rolled pipe : final reheating practice and hot sizing or stretch reducing; if applicable, upsetting, cold finishing;
- for seamless, heat-treated pipe : heat treatment;
- for electric-welded, as-rolled pipe : sizing and seam welding; if applicable, seam heat treatment and upsetting;
- for electric-welded, heat-treated pipe : seam welding and full-body heat treatment.

8.3 STARTING MATERIAL

8.3.1 The ingots, blooms, billets, strips or plates used as starting material for the manufacture of pipe shall be made from steel made by the basic oxygen or electric-furnace process.

8.3.2 For PSL 2 pipe, the steel shall be killed and made according to fine grain practice with a grain size of ASTM 7 or finer as per ASTM E 112.

(New) Steel shall be made by continuous casting only.

8.3.3 The strip or plate used for the manufacture of PSL 2 pipe shall not contain any repair welds.

	SPECIFICATION FOR BARE (ERW) & SEAMLESS LINE PIPES	DOCUMENT NO.	REV
		11-0290-02-07-02-003	0
		SHEET 5 OF 41	

(New) Pipes shall have longitudinal seam, manufactured using electric induction or electric resistance welding process.

8.3.4 Any lubricant that contaminates the weld bevel or the surrounding areas shall be removed before making the longitudinal seam welds of SAWL or COWL.

8.8 TREATMENT OF WELD SEAMS IN EW AND LW PIPES

8.8.2 LW PIPE AND PSL 2 HFW PIPE

The weld seam and the HAZ for all pipe grades shall be heat treated so as to stimulate a normalising heat treatment.

8.9 COLD SIZING AND COLD EXPANSION

Pipe furnished to this specification shall be non expanded.

8.12 HEAT TREATMENT

Heat treatments shall be performed in accordance with documented procedures.

(New) The pipes shall be produced from skelp which shall be quenched and tempered or controlled rolled or combined controlled rolled and accelerated cooled to impart uniformly fine ferritic grain structure to the finished steel. Other types of heat treatment shall be agreed upon between Purchaser and Manufacturer.

8.13 TRACEABILITY

8.13.2 For PSL 2 pipe, the manufacturer shall establish and follow documented procedures for maintaining the heat identity and the test-unit identity for all such pipe. Such procedures shall provide means for tracing any length of pipe to the proper test unit and the related chemical and mechanical test results.

9 ACCEPTANCE CRITERIA

9.2 CHEMICAL COMPOSITION

The chemical composition of each heat of steel on product analysis shall be as per table and notes given below. Table 5 of API Spec 5L 44th edition stands modified accordingly.

Table – 5: Chemical composition for PSL 2 pipe

Mass fraction based on heat and product Analysis

Element	Product Analysis (percent)	
C	0.16	max.
Mn	1.50	max. (for grade L 245 or B to L 360 or X52)
	1.60	max. (for grade L 390 X56 to L 485 or X70)
Si	0.15	min.
	0.45	max.
S	0.01	max.
P	0.02	max.
Al	0.07	max.
Nb	0.05	max.
V	0.08	max.

	SPECIFICATION FOR BARE (ERW) & SEAMLESS LINE PIPES	DOCUMENT NO.	REV
		11-0290-02-07-02-003	0
		SHEET 6 OF 41	

Ti	0.10	max.
Cr	0.20	max.
Mo	0.10	max.
Cu	0.35	max.
Ni	0.20	max.
N	0.012	max.
B	0.0005	max.

Note: f (New)

- i. V+Nb+Ti shall not exceed 0.15%
- ii. Cu+Ni shall not exceed 0.40%
- iii. Al/N shall be min. 2

Note: g (New)

If alloying elements other than those specified in Table 5 above are added to the steel, the limits of the additional components shall be agreed with the Purchaser.

Note: h (New)

Minimum for Si is not applicable for Al killed steel.

9.2.4 Carbon Equivalent (PSL 2 Only)

Calculation of Carbon Equivalent

Boron content shall be considered in CE (*Pcm*) formula even if it is less than 0.0005%.

Maximum Carbon Equivalent

For pipes of all grades, size and wall thickness, Carbon Equivalent shall comply with the following limits:

CE (<i>Pcm</i>)	◆	0.20%
CE (<i>IIW</i>)	◆	0.40%

9.3 TENSILE PROPERTIES

The finished pipes shall conform to the requirements of Table 7 of API Spec 5L 44th edition and as modified herein.

The actual yield strength shall be as close as possible to the specified minimum yield strength (SMYS) but in no case it shall exceed the limits specified here under:

API 5L Grade	Permissible in excess of SMYS, psi (MPa)
-----	-----
Upto and including X-46	19000 (131)
X-52 and above	22000 (152)

The ratio of body yield strength and body ultimate tensile strength of each test pipe on which body yield strength and body ultimate tensile strength are determined, shall not exceed 0.90.

	SPECIFICATION FOR BARE (ERW) & SEAMLESS LINE PIPES	DOCUMENT NO.	REV
		11-0290-02-07-02-003	0
		SHEET 7 OF 41	

The ultimate tensile strength of the weld shall be equal to or better than the specified minimum ultimate tensile strength of the base metal.

The minimum elongation of base metal shall be determined in accordance with the formula given in foot note (f) of Table 7 of API 5L, 44th Edition. However elongation in no case shall not be less than 20%, API 5L appendix D stands modified accordingly.

9.4 HYDROSTATIC TEST

(New) Test pressure shall be held for a minimum period of 15 seconds for all sizes and grades of pipes.

9.4.2 VERIFICATION OF HYDROSTATIC TEST

(New)

The pressure gauge used for hydrostatic testing shall have a minimum range of 1.5 times and maximum range of 4 times the test pressure. The pressure gauge shall be calibrated by means of a "Dead Weight" tester only.

In order to ensure that every length of pipe is tested to the required test pressure, each tester, except those on which only continuous welded pipe is tested, shall be equipped with a recording gauge that can record the test pressure and the test duration for each length of pipe, or shall be equipped with some positive and automatic or interlocking device to prevent pipe from being classified as tested until the test requirements (pressure and duration) have been met. Such records or charts shall be available for examination at the manufacturer's facility by the purchaser's inspector. The test-pressure measuring device shall be calibrated by means of a dead-weight tester, or equivalent, no more than four months prior to each use. Test pressures that are higher than required may be used.

9.4.3 TEST Pressure

(New) The test pressure for all sizes and grades of pipe shall be such that hoop stress generated is at least 95 % of SMYS.

9.4.5 Burst Test:

Burst Test shall be done on each type of pipe for each size on lowest thickness. Burst pressure & location of failure shall be recorded. Technical audit shall be carried out by Owner / Owner's representative during manufacturing.

Minimum Burst test pressure shall not be less than the actual tensile stress factor & computed pressure.

9.6 FLATTENING TEST ACCEPTANCE CRITERIA

Acceptance criteria for flattening tests shall be as follows:

- a) EW pipe in grades \geq L210 or A and LW pipe with $D < 323.9$ mm (12.750 in):
 - 1) For grades \geq L415 or X60 with $t \geq 12.7$ mm (0.500 in), there shall be no opening of the weld before the distance between the plates is less than 66 % of the original outside diameter. For all other combinations of pipe grade and specified wall thickness, there shall be no opening of the weld before the distance between the plates is less than 50 % of the original outside diameter.
 - 2) For pipe with a $D/t > 10$, there shall be no cracks or breaks other than in the weld before the distance between the plates is less than 33 % of the original outside diameter.
- b) EW and CW pipes in Grade L175, L175P, A25 or A25P:
 - 1) There shall be no opening of the weld before the distance between the plates is less than 75 % of the original outside diameter.

	SPECIFICATION FOR BARE (ERW) & SEAMLESS LINE PIPES	DOCUMENT NO.	REV
		11-0290-02-07-02-003	0
		SHEET 8 OF 41	

2) There shall be no cracks or breaks other than in the weld before the distance between the plates is less than 60 % of the original outside diameter.

NOTE1 The weld extends to a distance, on each side of the weld line, of 6.4 mm (0.25 in) for $D < 60.3$ mm (2.375 in) and 13 mm (0.5 in) for $D \geq 60.3$ mm (2.375 in).

NOTE2 For EW pipe that is processed through a hot-stretch mill and is flattened prior to such treatment, the original outside diameter is as designated by the manufacturer; for all other cases, the original outside diameter is the specified outside diameter.

Dye penetrant testing may be used to positively confirm the presence of crack, break or opening.

9.8 CVN IMPACT TESTS FOR PSL 2

GENERAL

9.8.1.1 If subsize test pieces are used, the required minimum average (set of three test pieces) absorbed energy values shall be the required values for full-size test pieces times the ratio of the specified width of the subsize test piece to the specified width of the full-size test piece, with such derived values rounded to the nearest joule (foot-pound force).

9.8.1.2 Individual test values for any test piece shall be ≥ 75 % of the required minimum average (of a set of three test pieces) absorbed energy values.

9.8.1.3 Tests conducted at temperatures lower than the specified test temperature shall be acceptable if the applicable requirements for energy absorption and shear fracture area are met at such lower temperatures.

9.8.2 PIPE BODY TESTS

9.8.2.1 The minimum average (of a set of three test pieces) absorbed energy for each pipe body test shall be as given in Table 8 of API 5L, 44th Edition, based upon full-size test pieces and a test temperature of 0 °C (32 °F) or a lower test temperature.

9.8.2.2 For welded pipe with $D \leq 508$ mm (20.000 in), if agreed, the minimum average (set of three test pieces) shear fracture area for each test shall be at least 85 %, based upon a test temperature of 0 °C (32 °F) or, if agreed, a lower test temperature.

9.8.3 PIPE WELD AND HAZ TESTS

The minimum average (of a set of three test pieces) absorbed energy for each pipe weld and HAZ test, based upon full-size test pieces and a test temperature of 0 °C (32 °F), or if agreed a lower test temperature, shall be 27 J.

9.9 DWT TEST FOR PSL 2 WELDED PIPE

9.9.1 For each test (of a set of two test pieces), the average shear fracture area shall be ≥ 85 %, based upon a test temperature of 0 °C (32 °F).

9.9.2 Tests conducted at temperatures lower than the specified test temperature shall be acceptable if the applicable requirements for shear fracture area are met at such lower temperatures.

9.10 SURFACE CONDITIONS, IMPERFECTIONS AND DEFECTS

9.10.1 GENERAL

9.10.1.1 All pipes shall be free from defects in the finished condition.



SPECIFICATION FOR BARE (ERW) &
SEAMLESS LINE PIPES

DOCUMENT NO.

REV

11-0290-02-07-02-003

0

SHEET 9 OF 41

Page 29 of 100

9.10.1.2 All pipes shall be free from cracks, sweats and leaks.

9.10.1.3 The acceptance criteria for imperfections found by non-destructive inspection shall be in accordance with Annex E.

9.10.3 ARC BURNS

9.10.3.1 Arc burns shall be classified as defects.

NOTE 2 Contact marks, which are intermittent marks adjacent to the weld line of EW pipe resulting from electrical contact between the electrodes supplying the welding current and the pipe surface, are treated in accordance with 9.10.7.

9.10.4 LAMINATIONS

Laminations or inclusions extending into the face or bevel of the pipe and having a visually determined length in the circumferential direction > 6.4 mm (0.250 in) shall be classified as defects. Pipes that contain such defects shall be rejected or cut back until no such lamination or inclusion is present at the pipe ends.

9.10.5 GEOMETRIC DEVIATIONS

9.10.5.1 For other than dents, geometric deviations from the normal cylindrical contour of the pipe (e.g. flat spots and peaks) that occur as a result of the pipe forming process or manufacturing operations and that exceed 3.2 mm (0.125 in) in depth, measured as the gap between the extreme point of the deviation and the prolongation of the normal contour of the pipe, shall be considered defects and shall be treated in accordance with C.3 b) or C.3 C) (Annexure C).

9.10.5.2 For dents, the length in any direction shall be $\leq 0.5 D$ and the depth, measured as the gap between the extreme point of the dent and the prolongation of the normal contour of the pipe, shall not exceed the following:

- a) 3.2 mm (0.125 in) for cold-formed dents with sharp-bottom gouges;
- b) 6.4 mm (0.250 in) for other dents.

Dents that exceed the specified limits shall be considered defects and shall be treated in accordance with C.3 b) or C.3 c) (Annexure C).

9.10.6 HARD SPOTS

Any hard spot larger than 50 mm (2.0 in) in any direction shall be classified as a defect if its hardness exceeds 248 HV10, based upon individual indentations. Pipes that contain such defects shall be treated in accordance with C.3 b) or C.3 c) (Annexure C).

9.10.7 OTHER SURFACE IMPERFECTIONS

Other surface imperfections found by visual inspection shall be investigated, classified and treated as follows:-

- a) Imperfections that have a depth $\leq 0.125 t$ and do not encroach on the minimum permissible wall thickness shall be classified as acceptable imperfections and shall be treated in accordance with Clause C.1 (Annexure C).
- b) Imperfections that have a depth $> 0.125 t$ and do not encroach on the minimum permissible wall thickness shall be classified as defects, and shall be dressed-out by grinding in accordance with Clause C.2 (Annexure C) or shall be treated in accordance with Clause C.3 (Annexure C).

	SPECIFICATION FOR BARE (ERW) & SEAMLESS LINE PIPES	DOCUMENT NO.	REV
		11-0290-02-07-02-003	0
		SHEET 10 OF 41	

c) Imperfections that encroach on the minimum permissible wall thickness shall be classified as defects and shall be treated in accordance with Clause C.3 (Annexure C).

NOTE Imperfections that encroach on the minimum permissible wall thickness” implies that the portion of the wall thickness that is beneath the surface imperfection is less than the minimum permissible wall thickness.

9.11 DIMENSIONS, MASS AND TOLERANCE

(New) Pipe Length

All pipes shall be supplied with length between 11.5 m and 12.5 m. The minimum average length of the entire order shall be 12.0 m. API 5L Table 12 shall not be applicable.

Pipe used for sampling or 5% of ordered quantity whichever is higher may be accepted for a length between 10.0 to 11.5mm.

The minimum overall length tolerance shall be (-) zero and (+) one pipe length to complete the ordered quantity.

Each pipe shall be measured for conformance to above requirements and all measurements shall be recorded.

(New) Wall thickness

In addition to API 5L requirements, the wall thickness of each pipe shall be checked along the circumference at both ends of pipe body at 3 ‘o’ clock, 6 ‘o’ clock, 9 ‘o’ clock & 12 ‘o’ clock Position. The wall thickness tolerance shall comply with the requirements of this specification.

The tolerances on specified wall thickness shall be (+) 10 % and zero negative tolerance. API Spec 5L Table 11 stands modified accordingly.

Wall thickness measurements shall be measured and recorded at least 3 times per operating shift (12 hours maximum).

(New) Pipe body

The outside diameter of pipe body, as determined by taping the circumference, shall not deviate by more than the values given. API Spec 5L Table 10 stands modified accordingly.

<u>Pipe Size</u>	<u>Tolerance</u>
≥4 ½ and < 20	± 0.75 % of Specified OD or ± 3 mm whichever is smaller
≥ 20 and < 24	+ 3 mm, - 0.25% of Specified OD

(New) Pipe end

Table 10 of API 5L shall be applicable for tolerances on pipe end.

(New) Out of roundness

Out of Roundness i.e., the difference between the maximum and minimum diameter (inside for pipe size ≥ 14 and outside for pipe size ≤ 12) at pipe ends shall comply with the following limits.

<u>Pipe Size</u>	<u>Tolerance</u>
<10 ¾	3 mm (Max)

	SPECIFICATION FOR BARE (ERW) & SEAMLESS LINE PIPES	DOCUMENT NO.	REV
		11-0290-02-07-02-003	0
		SHEET 11 OF 41	

≥12 ¾

5 mm (Max)

Out of roundness tolerance apply to maximum and minimum diameters as measured with a bar gauge, caliper or device measuring actual maximum and minimum diameter. Out of roundness tolerance indicated in API 5L Table 10 stands deleted.

Each pipe shall be measured for conformance to above requirements. All dimensions and tolerances shall be measured and recorded at least 3 times per operating shift (12 hrs maximum).

9.11.2 MASS PER UNIT LENGTH

The mass per unit length, ρ_i expressed in kilograms per metre (pounds per foot), shall be calculated using Equation (4):

$$\rho_i = t(D-t) \times C \tag{4}$$

where

D is the specified outside diameter, expressed in millimetres (inches);

t is the specified wall thickness, expressed in millimetres (inches);

C is 0.024 66 for calculations in SI units and 10.69 for calculations in USC units.

NOTE The nominal mass of a pipe is the product of its length and its mass per unit length.

9.11.3.4 The tolerances for straightness shall be as follows.

(New) The deviation from a straight line for each pipe length shall not exceed 1.0 mm per metre length of pipe with maximum permissible limit of 12mm.

Each pipe shall be checked for conformance to above requirements. The straightness shall be measured and recorded at least 3 times per shift (Shift time 12 hours maximum).

(New) **Jointers**

Jointers on pipes are not permitted.

9.12 FINISH OF PIPE ENDS

9.12.1 GENERAL

9.12.1.2 PSL 2 pipes shall be furnished with plain ends.

9.12.1.3 Pipe ends shall be free from burrs.

(New) In removing the inside burrs at the pipe ends, care shall be taken not to remove excess metal and not to form an inside cavity or bevel. Removal of excess metal beyond the minimum wall thickness shall be a cause for rebeveling. In case root face of bevel as specified in 9.12.5.2 is less than specified, the pipe ends shall be re-bevelled and rectification by filing or grinding shall not be done.

9.12.1.4 The out-of-squareness, measured as shown in Figure 3, shall be ≤ 1.6 mm (0.063 in).

9.12.5 PLAIN ENDS

9.12.5.2 The end faces of plain-end pipe with $t > 3.2\text{mm}$ (0.125 in) shall be bevelled for welding. Except as allowed by 9.12.5.3, the angle of the bevel, measured from a line drawn perpendicular to the axis of the pipe, shall be 30° with a tolerance of (+) 5°, (+) 0° and the width of the root face of the bevel shall be 1.6 mm (0.063 in), with a tolerance of ± 0.8mm (0.031 in).



SPECIFICATION FOR BARE (ERW) & SEAMLESS LINE PIPES

DOCUMENT NO.

REV

11-0290-02-07-02-003

0

SHEET 12 OF 41

9.12.5.4 Where internal machining or grinding is carried out, the angle of the internal taper, measured from the longitudinal axis, shall not exceed the following:

- a) For SMLS pipe, the applicable value given in Table 13 of API 5L, 44th Edition;
- b) For the weld seam of welded pipe, 7.0⁰.

9.13 TOLERANCES FOR WELD SEAM

For EW and LW pipes, the radial offset of the strip/plate edges [see figure 4 (a)] shall not cause the remaining wall thickness at the weld to be less than the minimum permissible wall thickness.

(New) Offset of the prepared edges at the pipe joint shall not exceed 1.6 mm for wall thickness up to 12.7 mm, for wall thickness in excess of 12.7mm shall not exceed 12.5% of specified wall thickness with a maximum limit of 3.2mm.

All pipes shall be checked for offset of skelp edges. Offset shall be measured and recorded at least 3 times per operating shift (12 hours maximum).

9.13.2 HEIGHT OF FLASH OR WELD/BEAD REINFORCEMENT

9.13.2.1 For EW and LW pipes, the following shall apply.

- a) The outside flash shall be trimmed to an essentially flush condition.
- b) The inside flash shall not extend above the contour of the pipe by more than 1.5 mm (0.060 in).
- c) The wall thickness at the trim shall not be less than the minimum permissible wall thickness.
- d) The depth of groove resulting from trimming the internal flash shall not exceed the applicable value given in Table 15 of API 5L.

9.15 WELDABILITY OF PSL 2 PIPE

Weldability test shall be conducted at pipe mill on first day's production. This shall ensure Weldability & strength as per code.

The manufacturer shall supply weldability data for the type of steel concerned or perform weldability tests as per WPS & PQR approved by client/consultant.

Contractor shall accordingly arrange for the welders to carry out the WPS / PQR at the pipe mill. Establishing the WPS/PQR of pipe mill doesn't absolve the EPC contractor of his responsibilities.

The requirements for the chemical composition of the steels and, in particular, the limiting values of CEpcm and CEllw shall be as per clause 9.2 & 9.2.4 of this specification

10 INSPECTION

10.1 TYPES OF INSPECTION & INSPECTION DOCUMENTS

10.1.3 GENERAL

10.1.1.1 Compliance with the requirements of the purchase order shall be checked by specific inspection.

10.1.1.2 Inspection documents shall be in printed form or in electronic form as an EDI transmission that conforms to any EDI agreement between the purchaser and the manufacturer.

10.1.3 INSPECTION DOCUMENTS FOR PSL 2 PIPE

	SPECIFICATION FOR BARE (ERW) & SEAMLESS LINE PIPES	DOCUMENT NO.	REV
		11-0290-02-07-02-003	0
		SHEET 13 OF 41	

The following information, as applicable, shall be provided for each order item:-

- a) Specified outside diameter, specified wall thickness, pipe grade, PSL, type of pipe and the delivery condition;
- b) Chemical composition (heat and product) and carbon equivalent (product analysis and acceptance criterion);
- c) Tensile test results and the type, size, location and orientation of the test pieces;
- a) CVN impact test results; the size, orientation and location of the test pieces; the test temperature; and the acceptance criteria for the specific test piece sizes used;
- e) For welded pipe, DWT test results (individual and average test results for each test);
- f) Specified minimum hydrostatic test pressure and specified test duration;
- g) For welded pipe, the method of non-destructive weld inspection (radiological, ultrasonic, or electromagnetic) used; and the type and size of reference indicator or image quality indicator used;
- h) For SMLS pipe, the method of non-destructive inspection (ultrasonic, electromagnetic or magnetic particle) used; and the type and size of the reference indicator used;
- l) For HFW pipe, the minimum temperature for heat treatment of the weld seam;
- j) Results of any supplementary testing specified in the purchase order.

10.2 SPECIFIC INSPECTION

10.2.1.2 For PSL 2 pipe the inspection frequency shall be as per table given below. API 5L Table 18 stands modified accordingly.

Type of inspection	Type of pipe	Frequency of inspection
Heat analysis	All pipe	One analysis per heat of steel
Product analysis	SMLS, HFW	Two pipes per heat per lot of 50 pipes. Pipes selected shall be such that one at the beginning of the heat and one at end of heat are represented.
Tensile testing of the pipe body	SMLS, HFW	Tensile tests shall be made at the frequency of two pipes per inspection lot. Inspection lot shall be 100 pipes per heat.
Tensile testing of the longitudinal or helical seam weld of welded pipe with $D \geq 219.1$ mm (8.625 in)	HFW	Two pipes per inspection lot. Inspection lot shall consists of 100 pipes per heat.
CVN impact testing of the pipe body of pipe with specified outside diameter and specified wall thickness as given in Table	SMLS, HFW	Specimen should be taken from the body of the pipe, with three transverse specimens with weld in middle and three transverse specimen with heat

	SPECIFICATION FOR BARE (ERW) & SEAMLESS LINE PIPES	DOCUMENT NO.	REV
		11-0290-02-07-02-003	0
		SHEET 14 OF 41	

22 of API 5L, 44 th Edition.		affected zone (HAZ) in the middle.
DWT testing of the pipe body of welded pipe with $D \geq 508$ mm (20.000 in)	HFW	Two transverse specimen shall be taken from one length of pipe per heat per lot of 100 pipes per combination of pipe size and specified wall thickness.
Flattening test of welded pipe.	HFW	As shown in Fig. 6.
Hardness testing of hard spots in cold- formed welded pipe	HFW	Any hard spot exceeding 50 mm (2.0 in) in any direction
Hydrostatic testing	SMLS, HFW	Each pipe
Metallographic testing (or optional hardness test in lieu of metallography) of the longitudinal seam weld of welded pipe	HFW	At least once per operating shift plus whenever changes of grade, specified outside diameter or specified wall thickness are made; plus whenever significant excursions from operating heat treatment conditions are encountered.
Visual inspection	SMLS, HFW	Each pipe, except as allowed by 10.2.7.2
Pipe diameter and out-of-roundness	SMLS, HFW	At least once per 4 h per operating shift plus whenever any change of pipe size occurs during the operating shift
Wall thickness measurement	All pipes	Each pipe (see 10.2.8.5)
Other dimensional testing	SMLS, HFW	At least once/operating shift and whenever there is any change of pipe size occurring during operating shift.
Non-destructive inspection	SMLS, HFW	In accordance with Annex E

Table 18 – Inspection frequency for PSL 2 pipe

10.2.2 SAMPLES AND TEST PIECES PREPARED

Samples shall be taken, and test pieces prepared, in accordance with ISO 14284 or ASTM E1806. Such samples shall be taken from the pipe, plate or strip. Samples for product from plate or strip may be used provided traceability of samples is guaranteed.

	SPECIFICATION FOR BARE (ERW) & SEAMLESS LINE PIPES	DOCUMENT NO.	REV
		11-0290-02-07-02-003	0
		SHEET 15 OF 41	

10.2.3 SAMPLES AND TEST PIECES FOR MECHANICAL TESTS

10.2.3.1 GENERAL

For tensile tests, CVN impact tests, DWT tests and flattening tests, the samples shall be taken, and the corresponding test pieces prepared, in accordance with the applicable reference standard.

Samples and test pieces for the various test types shall be taken from locations as shown in Figure 5 (a & b) and Figure 6 and as given in Table 20 of API 5L, 44th edition, whichever is applicable, taking into account the supplementary details in 10.2.3.2 to 10.2.3.7.

For any of the mechanical tests specified in Clause 9, any test piece that shows defective preparation or material imperfections unrelated to the intent of the particular mechanical test, whether observed before or after testing, may be discarded and replaced by another test piece from the same length of pipe.

10.2.3.2 TEST PIECES FOR THE TENSILE TEST

Rectangular test pieces, representing the full wall thickness of the pipe, shall be taken in accordance with ISO 6892 or ASTM A 370 and as shown in Figure 5 (a & b); transverse test pieces shall be flattened. Two transverse base metal specimen and two transverse weld metal specimen for tensile test shall be tested. In case transverse base metal specimen is not applicable as per Fig 5 & Table 20 of API Spec 5L, longitudinal specimen may be taken. Table 20 of API 5L stands modified accordingly.

Alternatively, round test pieces obtained from non-flattened samples may be used. For longitudinal tensile tests of pipe with $t \geq 19.0$ mm (0.748 in), such test pieces shall be 12.7 mm (0.500 in) in diameter. For transverse tensile tests, the diameter of such test pieces shall be as given in Table 21 of API 5L, 44th edition, except that the next larger diameter may be used at the option of the manufacturer. For testing pipe with $D < 219.1$ mm (8.625 in), full-section longitudinal test pieces may be used at the option of the manufacturer.

(New) Inside and outside flash of weld in excess of pipe wall thickness shall be removed from the specimen either by grinding or machining.

Ring expansion test pieces may be used for the determination of transverse yield strength.

Weld beads shall be ground flush and local imperfections shall be removed.

10.2.3.3 TEST PIECES FOR THE CVN IMPACT TEST

The test pieces shall be prepared in accordance with ASTM A 370. The axis of the notch shall be perpendicular to the pipe surface.

For pipe weld and HAZ tests, each test piece shall be etched prior to notching in order to enable proper placement of the notch.

For test pieces taken in the weld of HFW pipe, the axis of the notch shall be located on, or as close as practical to, the weld line.

10.2.3.4 TEST PIECES FOR DWT TEST

The test pieces shall be prepared in accordance with API RP 5L3.

10.2.3.7 TEST PIECES FOR THE FLATTENING TEST

The test pieces shall be taken in accordance with ISO 8492 or ASTM A 370, except that the length of each test piece shall be 60 mm (2.5 in).

Minor surface imperfections may be removed by grinding.



SPECIFICATION FOR BARE (ERW) &
SEAMLESS LINE PIPES

DOCUMENT NO.

REV

11-0290-02-07-02-003

0

SHEET 16 OF 41

Page 36 of 100

10.2.5 MACROGRAPHIC AND METALLOGRAPHIC EXAMINATION

10.2.5.3 For pipe that is required to be seam-heat-treated, it shall be verified by metallographic testing that the entire HAZ has been appropriately heat treated over the full wall thickness.

(New) A test specimen for metallographic & hardness examination shall be taken transverse to the longitudinal weld, from one finished pipe from each lot of 50 pipes per heat or at least once per operating shift (12 hrs maximum) whichever is occurring more frequently and whenever changes of grade, diameter or wall thickness are made and whenever significant excursions from operating heat treatment conditions are encountered. The specimen shall be suitably ground, polished and etched to reveal the macro-structure. The specimen shall be visually examined using a minimum 10X magnification to provide evidence that heat treatment of weld zone is adequate and there is no untempered martensite left. In case defects are observed, it will become a cause for re-evaluation of welding parameters and heat treatment as deemed necessary by Purchaser's Representative.

(New) Vickers hardness tests shall be carried out on each specimen taken for metallographic examination in accordance with ASTM E-92, at locations indicated in Fig. 10 i.e. at fusion line, heat affected Zone & body of this specification. The resulting Vickers hardness value at any point shall not exceed 248 HV₁₀. The maximum difference in hardness between the base metal and any reading taken on the weld or heat affected zone shall be less than 80 HV₁₀.

10.2.6 HYDROSTATIC TEST

Hydro testing of the pipe shall be as per clause no. 9.4 of this specification.

10.2.6.5 Except as allowed by 10.2.6.6 and the footnotes to Table 26 of API 5L, 44th edition, the hydrostatic test pressure, *P*, expressed in megapascals (pounds per square inch), for plain-end pipe shall be determined using Equation (6), with the results rounded to the nearest 0.1 MPa (10 psi):

$$P = \frac{2St}{D} \tag{6}$$

where

'S' is the hoop stress, expressed in megapascals (pounds per square inch), equal to a percentage of the specified minimum yield strength of the pipe, as given in Table 26 of API 5L, 44th edition.

't' is the specified wall thickness, expressed in millimetres (inches).

'D' is the specified outside diameter, expressed in millimetres (inches).

10.2.6.6 If pressure testing involves an end-sealing ram that produces a compressive longitudinal stress, the hydrostatic test pressure, *P*, expressed in megapascals (pounds per square inch), may be determined using Equation (7), with the result rounded to the nearest 0.1 MPa (10 psi), provided that the required test pressure produces a hoop stress in excess of 95 % of the specified minimum yield strength:

$$P = S - \frac{(P_R \times A_R)}{\frac{D - A_1}{2t} A_p} \tag{7}$$

where

'S' is the hoop stress, expressed in megapascals (pounds per square inch), equal to a percentage of the specified minimum yield strength of the pipe (see Table 26 of API 5L, 44th edition).

'P_R' is the internal pressure on end-sealing ram, expressed in megapascals (pounds per square inch).

	<p align="center">SPECIFICATION FOR BARE (ERW) & SEAMLESS LINE PIPES</p>	DOCUMENT NO.	REV
		11-0290-02-07-02-003	0
		SHEET 17 OF 41	

'A_R' is the cross-sectional area of end-sealing ram, expressed in square millimetres (square inches).

'A_p' is the cross-sectional area of pipe wall, expressed in square millimetres (square inches).

'A₁' is the internal cross-sectional area of pipe, expressed in square millimetres (square inches).

'D' is the specified outside diameter, expressed in millimetres (inches).

't' is the specified wall thickness, expressed in millimetres (inches).

10.2.7 VISUAL INSPECTION

10.2.7.1 Except as allowed by 10.2.7.2, each pipe shall be visually inspected to detect surface defects, with an illuminance of at least 300 lx (28 fc). Such inspection shall be over the entire external surface and shall cover as much of the internal surface as is practical.

10.2.7.2 Visual inspection may be replaced by other inspection methods that have a demonstrated capability of detecting surface defects.

10.2.7.3 Visual inspection shall be conducted by personnel who:-

a) Are trained to detect and evaluate surface imperfections.

b) Have visual acuity that meets the applicable requirements of ISO 11484 or ASNT SNT-TC-1A or equivalent.

10.2.7.4 The surface of cold-formed welded pipe shall be inspected to detect geometric deviations in the contour of the pipe. If this inspection fails to disclose mechanical damage as the cause of the irregular surface, but indicates that the irregular surface can be attributed to a hard spot, the dimensions of the area, and if necessary its hardness, shall be determined. The choice of the test method for hardness testing is at the option of the manufacturer. If the dimensions and hardness exceed the acceptance criteria given in 9.10.6, the hard spot shall be removed in accordance with procedures specified in 9.10.7 and Annexure C.

10.2.8 DIMENSIONAL TESTING

10.2.8.1 The diameter of pipes shall be measured at least once per 4 h per operating shift. Unless a specific method is specified in the purchase order, diameter measurements shall be made with a circumferential tape, ring gauge, snap gauge, calliper or optical measuring device.

10.2.8.2 The out-of-roundness of pipes shall be determined at least once per 4 h per operating shift. The out-of-roundness shall be determined as the difference between the largest outside diameter and the smallest outside diameter, as measured in the same cross-sectional plane.

10.2.8.5 Each length of pipe shall be measured for conformance to the specified wall thickness requirements. The wall thickness at any location shall be within the tolerances specified in Clause No.- 9.11, except that the weld area shall not be limited by the plus tolerance. Wall thickness measurements shall be made with a mechanical calliper or with a properly calibrated non-destructive inspection device of appropriate accuracy. In case of dispute, the measurement determined by use of the mechanical calliper shall govern.

10.2.9 WEIGHING

For pipe with $D \geq 141.3$ mm (5.563 in), the lengths of pipe shall be weighed individually. For pipe with $D < 141.3$ mm (5.563 in), the lengths of pipe shall be weighed either individually or in convenient lots selected by the manufacturer.

10.2.10 NON-DESTRUCTIVE INSPECTION

	SPECIFICATION FOR BARE (ERW) & SEAMLESS LINE PIPES	DOCUMENT NO.	REV
		11-0290-02-07-02-003	0
		SHEET 18 OF 41	

Non-destructive inspection shall be in accordance with Annex E.

10.2.12 RETESTING

10.2.12.1 Except as allowed by 10.2.12.2, retesting shall be in accordance with ISO 404.

10.2.12.2 If one or both of the retests representing a test unit fail to conform to the specified requirements, the manufacturer may elect to test each of the remaining lengths in the test unit for conformance to the specified requirements, with any non-conforming lengths being rejected.

(New) In the event that a set of Charpy test specimen fails to meet the acceptance criteria, the Manufacturer may elect to replace the lot of material involved or alternatively to test two more lengths from that lot. If both the new tests meet the acceptance criteria, then all pipe in that lot (refer para 10.2.1.2 of this specification), with the exception of the original selected length, shall be considered to meet the requirement.

11 MARKING

Marking specified in API Paragraphs and otherwise specified in the Purchase Order shall be in English language and international system (SI) of units. Marking shall comply with Clause 11 of API Spec 5L and as modified in this specification.

12 COATING AND THREAD PROTECTORS

12.2 BEVEL PROTECTORS

(New)

Both pipe ends of all pipes shall be provided with metallic or high impact plastic bevel protectors as per Manufacturer's standard. Bevel protectors shall be of a design such that they can be re-used by coating applicator for providing on externally anti-corrosion coated pipes subsequent coating of line pipe.

13 RETENTION OF RECORDS

Records of the following inspections, if applicable, shall be retained by the manufacturer and shall be made available to the purchaser, upon request, for a period of three years after the date of purchase from the manufacturer.

- a) heat and product analyses;
- b) tensile tests;
- c) guided-bend tests;
- d) CVN tests;
- e) DWT tests;
- f) hydrostatic-tester recorder charts or electronic methods of record storage;
- g) radiographic images for pipe inspection;
- h) non-destructive inspection by other methods where applicable;
- i) qualifications of non-destructive inspection personnel;
- j) radiographic images for jointer welds;
- k) repair welding procedure tests;

	SPECIFICATION FOR BARE (ERW) & SEAMLESS LINE PIPES	DOCUMENT NO.	REV
		11-0290-02-07-02-003	0
		SHEET 19 OF 41	

l) records of any other test as specified in the annexure or the purchase order, including all welding procedure specifications (WPS) and welding-procedure qualification test records (WPQT/PQR).

In addition to the records indicated in API Spec 5L, the Manufacturer shall retain the records of all additional tests/calibration records mentioned in this specification including the hard copy records of ultrasonic testing carried out on pipe/skelp as well as pipe ends.

13.1 PRODUCTION REPORT

(New) The Manufacturer shall provide six copies of production report in English language indicating at least the following for each pipe. International system of units (SI) shall be adopted.

- Pipe number
- Heat number from which pipe is produced
- Pipe length and weight.
- Pipe grade

The Manufacturer shall provide six copies of acceptance certificates which shall include the results of all tests required as per this specification and performed on delivered material giving details of, but not limited to, the following:

- All test certificates.
- Certified reports of dimensional, workmanship and defects inspection.
- Data on test failures, rejected heats/lots, etc.
- All other reports, results and records required as per this specification.

The certificates shall be valid only when signed by the Purchaser's Representative. Only those pipes, which have been certified by the Purchaser's Representative, shall be dispatched from the pipe mill.

In the event of small quantities of pipes supplied against this specification, like those for bends and other similar applications, as specifically called out in the Purchase Order, the production report may consist of only test certificates required as per API Spec 5L and other test reports/results required as per this specification.

13.2 LINEPIPE TRACKING DATA

(New)

The line pipe data shall be provided in PDF format in CD/DVD. The specific data to be recorded shall be agreed between Purchaser and the Manufacturer and shall include, but not limited to, the following:

- All marking information
- Date of plate and pipe manufacture
- All mechanical properties from test results
- All dimensional records
- Final inspection and release date
- Description and disposition of repairs
- Load-out despatch date
- Destination
- Consignment details

	SPECIFICATION FOR BARE (ERW) & SEAMLESS LINE PIPES	DOCUMENT NO.	REV
		11-0290-02-07-02-003	0
		SHEET 20 OF 41	

14 PIPE LOADING

If the manufacturer is responsible for the shipment of pipe, the manufacturer shall prepare and follow loading diagrams that detail how the pipe is to be arranged, protected and secured on trucks, railcars, barges or ocean-going vessels, whichever is applicable. The loading shall be designed to prevent end damage, abrasion, peening and fatigue cracking. The loading shall comply with any rules, codes, standards or recommended practices which are applicable.

NOTE For additional information refer to API RP 5L1 (19) and API RP 5LW 1201.

15 INSPECTION OF FIELD TEST AND WARRANTY

(New) Purchaser shall be reimbursed by Manufacturer for any pipe furnished on this order that fails under field hydrostatic test if such failure is caused by a material manufacturing defect in the pipe. The reimbursement cost shall include pipe, labour and equipment rental for finding, excavating, cutting out and installation of replaced pipe in position. The hydrostatic test pressure will not exceed that value which will cause a calculated hoop stress equivalent to 95 percent of specified minimum yield strength.

In case Manufacturer so desires, he will be advised at least two weeks in advance so that his representative may witness the hydrostatic test, however, the testing and leak (if any) finding and repair operation shall not be postponed because of absence of the Manufacturer's Representative.

	SPECIFICATION FOR BARE (ERW) & SEAMLESS LINE PIPES	DOCUMENT NO.	REV
		11-0290-02-07-02-003	0
		SHEET 21 OF 41	

APPENDIX I : MANUFACTURING PROCEDURE SPECIFICATION

A Manufacturing Procedure Specification (MPS) outlining the successive steps and associated inspection procedures from steel making to finished line pipe shall be prepared and submitted to Purchaser for approval prior to start of production. Manufacture of pipes shall start only after the approval of Manufacturing Procedure. The approved Manufacturing Procedure shall be strictly followed in all phases of the production of pipes.

The manufacturing procedure shall as a minimum include the following information.

- Steel/Plate/skelp maker and plant at which steel is produced.
- Steel making process with details of secondary refining process and continuous casting process, nominal weight of each heat.
- Target chemistry, range of intentionally added elements, limits on heat and product analysis to be placed on steel maker.
- Plate/skelp rolling procedure indicating number of passes, their temperature and thickness reduction in each pass required by Controlled Rolling Procedure and the finishing temperature.
- Heat treatment procedure document established as per para 8.12.
- Ultrasonic testing of plates/skelp and pipes using automatic and manual equipment including details of equipment, techniques, scanning pattern, probe frequency, scanning sensitivity, reference standard for calibration, dynamic calibration procedure, method of marking defects and indicating loss of coupling, inspection and recording.
- Pipe making procedure including plate edge preparation, forming and any other special process proposed.
- Welding procedure specification including the details of welding process, brand name, classification, size and grade of filler metal and flux, speed of welding, number of electrodes and polarity of each electrode, welding current and voltage for each wire, edge preparation, tack welding method and spacing of tack weld, details of seam tracking system for both inside and outside welding, method of checking the setup of the system, limits of internal and external weld reinforcement etc.

In addition to be WPS carried out at mill WPS & PQR shall be carried out at the pipe mill by approved welders of the EPC Contractor to establish the weldability of pipe.

EPC Contractor accordingly arrange for the welders to carry out the WPS / PQR at the pipe mill. Establishing the WPS of pipe mill doesn't absolve the EPC contractor of his responsibility of carrying out WPS / PWR at site.

- Method of weld defect removal.
- Ultrasonic testing of longitudinal weld seam of pipe using automatic equipment including details of equipment, scanning pattern, probe frequency, scanning sensitivity, calibration pipe, extent of weld length at pipe ends not covered by all probes, method of marking defect and indicating loss of coupling, inspection and records.
- Full details of radiographic testing equipment including radiographic film.
- Dimensional tolerances, frequency of checking, measurement and record in a tabular form including details of instruments and equipments proposed.
- Detail of techniques proposed for measurement of end square ness and peaking at the welds.
- Hydrostatic testing including details of testing equipment, procedure and the relevant test pressure calculations.

	SPECIFICATION FOR BARE (ERW) & SEAMLESS LINE PIPES	DOCUMENT NO.	REV
		11-0290-02-07-02-003	0
		SHEET 22 OF 41	

- Marking details.
- Handling, storage and shipment procedure.
- Production Report Formats.
- Complete details of computerized pipe tracking system.

Note: In the event of small quantities of pipe ordered against this specification, the requirements of submission of manufacturing procedure details can be moderated subject to agreement between Purchaser and Manufacturer.

	SPECIFICATION FOR BARE (ERW) & SEAMLESS LINE PIPES	DOCUMENT NO.	REV
		11-0290-02-07-02-003	0
		SHEET 23 OF 41	

APPENDIX II (NEW): - FIRST DAY PRODUCTION TESTS

Three lengths each of completely finished pipes of first day's production from three different heats shall be selected at random for testing to verify that the manufacturing procedure results in the quality of pipes which are in complete compliance with this specification. The pipes thus tested shall be considered to be the test pipes required per heat or per lot as per relevant clauses of this specification.

These first day's production tests shall be repeated upon any change in the manufacturing procedure as deemed necessary by Purchaser Representative. The first day production tests shall be carried out on pipes for each wall thickness, each diameter and each grade of steel.

The Manufacturer shall submit to Purchaser a report giving the results of all tests mentioned below. The report shall be agreed and signed by Purchaser Representative, prior to start of regular production.

Note: In the event of small quantities of pipes ordered against this specification, like those for bends and other similar applications, as specifically called out in the Purchase Order, the first day production test shall not be carried out. Pipes in such case shall be accepted based on regular production tests.

The various tests to be conducted on each pipe shall be as follows. The test method and acceptance values shall be as per this specification unless specified differently in this Annexure.

a. Visual Examination

All pipes shall be examined visually for dimensional tolerances and apparent surface defects.

b. Ultrasonic Examination

All pipes shall be examined by automatic Ultrasonic equipment as per Annexure-E of this specification.

c. Mechanical Properties

The mechanical properties of all pipes shall be tested and shall meet the requirements of this specification. Purchaser Representative will select the locations on the pipe from where the test specimen shall be removed.

The following tests shall be conducted:

- i. Two (2) flattening test specimens shall be removed; one specimen shall be tested with weld at 0° and other at 90°.
- ii. Two (2) transverse base metal specimen and two transverse weld specimen for tensile test shall be tested. In case transverse base metal specimen is not applicable as per Fig. 5 and Table 20 of API Spec 5L, longitudinal specimen may be taken.
- iii. Six (6) weld cross-section specimen, three (3) from each end of the pipe joint, shall be taken for metallographic examination. Two of these specimens shall be tested for hardness at room temperature after etching.
- iv. Fracture toughness testing specimen shall be extracted as specified in clause 9.8 and clause 10.2.3 of this specification:
 - Four sets of three transverse specimens each from base metal
 - One set of 3 transverse specimens with weld in middle
 - One set of 3 transverse specimens with HAZ in middle

The base metal specimen shall be tested at -10, 0, +20°C for shear area and absorbed energy.

	SPECIFICATION FOR BARE (ERW) & SEAMLESS LINE PIPES	DOCUMENT NO.	REV
		11-0290-02-07-02-003	0
		SHEET 24 OF 41	

- v. At points selected by Purchaser, 12 DWTT specimens shall be removed from base metal in a transverse direction. The sets of 3 base metal specimen shall be tested at -10, 0, +20°C for shear area. The value at the test temperature specified in Clause 9.9 of this specification shall be used to evaluate the test. Full transition curve shall be established for the heat.

(Note: This test is to be carried out only when required as per Clause 9.9 and Clause 10.2 of this specification.)

- d. Weldability test shall be conducted at pipe mill on first day's production. This shall ensure Weldability & strength as per code. Welding shall be done as per WPS approved by OWNER / OWNER's representative.

e. **Impact Test**

Charpy V-notch impact test shall be carried out at 0 °C or at lower temperatures provided requirements for energy absorption and shear fracture area are met at such lower temperatures.

Charpy V- notch test specimen shall be prepared accordance with Clause 10.2.3.3. A set of three specimens shall be taken from following position of pipe body:

- The base material
- Fusion line
- The heat affected zone at 2 mm & 5mm from the fusion line.

The acceptance criteria for absorbed energy values for three full sized specimens shall be as given below:

	Base Metal (Joules)	Weld Metal and HAZ (Joules)
Minimum individual value	22.0 J	22.0 J
Minimum average value	27.0 J	27.0 J

In addition, all the tests and inspections require to be conducted as per this specification shall be conducted on all the pipes selected for testing during first day production test.

	SPECIFICATION FOR BARE (ERW) & SEAMLESS LINE PIPES	DOCUMENT NO.	REV
		11-0290-02-07-02-003	0
		SHEET 25 OF 41	

ANNEXURE C

Treatment of surface imperfections and defects

C.1 Treatment of surface imperfections

Surface imperfections not classified as defects may remain in the pipe without repair or may be cosmetically dressed-out by grinding.

C.2 Treatment of dressable surface defects

C.2.1 All dressable surface defects shall be dressed-out by grinding.

C.2.2 Grinding shall be carried out in such a way that the dressed area blends in smoothly with the contour of the pipe.

C.2.3 Complete removal of defects shall be verified by local visual inspection, aided, where necessary, by suitable non-destructive inspection methods. To be acceptable, the wall thickness in the ground area shall be in accordance with Clause 9.11; however, the minus tolerances for diameter and out-of-roundness (see 9.11) shall not apply in the ground area.

C.3 Treatment of non-dressable surface defects

Pipes that contain non-dressable surface defects shall be given one or more of the following dispositions.

- b) The sections of pipe containing the surface defects shall be cut off, within the limits on length.
- c) The entire pipe length shall be rejected.

C.4 Repair of defects by welding

C.4.1 For PSL 2 pipe, repair of the pipe body by welding is not permitted.

	SPECIFICATION FOR BARE (ERW) & SEAMLESS LINE PIPES	DOCUMENT NO.	REV
		11-0290-02-07-02-003	0
		SHEET 26 OF 41	

ANNEXURE E

Non-destructive inspection for other than sour service or offshore service

E.1 Qualification of personnel

E.1.1 ISO 11484 or ASNT SNT-TC-IA or an equivalent, shall be the basis for the qualification of non-destructive inspection personnel (excluding visual inspection). Such personnel shall be re-qualified for any method previously qualified, if they have not performed non-destructive inspection in that method for a period exceeding 12 months.

E.1.2 Non-destructive inspection shall be conducted by Level 1, 2 or 3 personnel.

E.1.3 Evaluation of indications shall be performed by Level 2 or 3 personnel, or by Level I personnel under the supervision of Level 2 or 3 personnel.

NOTE Levels 1, 2 and 3 in ISO 11484 correspond to Levels I, II and III in ASNT SNT-TC-1A.

E.2 Standard practices for inspection

Except as specifically modified in this annex, the required non-destructive inspection, other than for surface inspection (see 10.2.7) and wall-thickness verification, shall be performed in accordance with one of the following standards or an equivalent:

- a) electromagnetic (flux leakage): ISO 9402, ISO 9598 or ASTM E 570;
- b) electromagnetic (eddy-current): ISO 9304 or ASTM E 309;
- c) ultrasonic: ISO 9303, ISO 9305, ISO 10124, ISO 11496, ISO 12094, ISO 13663 or ASTM E 213; ASTM A 435 or ASTM A 578;
- d) ultrasonic (weld seam): ISO 9764, ISO 9765 or ASTM E 213;
- e) magnetic particle: ISO 13664, ISO 13665 or ASTM E 709;
- f) radiographic: ISO 12096 or ASTM E 94;
- g) liquid penetrant: ISO 12095 or ASTM E 165.

E.3 Methods of inspection

E.3.1 General

E.3.1.1 For Grades \geq L210 or A, the weld seams of welded pipe with $D \geq 60,3$ mm (2.375 in) shall be non-destructively inspected, full length (100 %) for the entire thickness, as given in Table E.1. In addition, the strip/plate-end weld in finished helical-seam pipe shall be non-destructively inspected, full length (100 %) for the entire thickness, as given in Table E.1.

	SPECIFICATION FOR BARE (ERW) & SEAMLESS LINE PIPES	DOCUMENT NO.	REV
		11-0290-02-07-02-003	0
		SHEET 27 OF 41	

Table E.1 — Pipe-weld seam non-destructive inspection

Weld seam type	Non-destructive inspection method ^a		
	Electromagnetic	Ultrasonic	Radiographic
EW	one method or a combination of methods is required		not applicable
LW	not applicable	required	not applicable
SAW	not applicable	required ^b	if agreed
COW	not applicable	required	not applicable
Strip/plate end	not applicable	required ^b	if agreed

^a The weld seam at the pipe ends may require additional inspection (see E.3.2).
^b Required unless the manufacturer and the purchaser have agreed to replace it by radiographic inspection.

E.3.1.2 All PSL 2 SMLS pipe shall be non-destructively inspected full length (100 %), as given in Table E.2. The method of inspection on pipe body or skelp preferably shall be through Ultrasonic method.

Table E.2 — SMLS pipe body non-destructive inspection

Item	Non-destructive inspection method		
	Electromagnetic	Ultrasonic	Magnetic particle (circular field)
PSL 2 pipe, any grade	one method or a combination of methods is required		
PSL 1 pipe, Grade L245 or B, quenched and tempered	one method or a combination of methods is required		
PSL 1 pipe, other than above	if agreed, one method or a combination of methods is required		

E.3.1.3 The location of equipment in the manufacturer’s facility shall be at the discretion of the manufacturer, except that

- a) The required non-destructive inspection of SMLS pipe shall take place after all heat treating and cold-expansion operations, if performed, but may take place before cropping, bevelling and end sizing;
- b) The weld seams in EW and HFW pipes shall be inspected following hydrostatic test.

E.3.2 Pipe end inspection — Welded pipe

E.3.2.1 If an automated ultrasonic or electromagnetic inspection system is applied to meet the requirements of E.3.1.1, the weld at any pipe ends that are not covered by the automated inspection system shall be inspected for defects by the manual or semi-automatic ultrasonic angle beam method or by the radiographic method, whichever is appropriate, or such non-inspected pipe ends shall be cut off.

E.3.2.3 Ultrasonic inspection in accordance with the method described in ASTM A 578 and ASTM A 435 or ISO 11496 shall be used to verify that the 25 mm (1.0 in) wide zone at each pipe end is free of laminar imperfections > 6.4 mm (0.25 in) in the circumferential direction.

E.3.3 Pipe end inspection — SMLS pipe

E.3.3.1 If an automated ultrasonic or electromagnetic inspection system (combined equipment, operating procedures and personnel) is applied to meet the requirements of E.3.1.2, the portion at

	SPECIFICATION FOR BARE (ERW) & SEAMLESS LINE PIPES	DOCUMENT NO.	REV
		11-0290-02-07-02-003	0
		SHEET 28 OF 41	

the pipe end that is not covered by the automated inspection system shall be inspected for defects by the manual or semiautomatic ultrasonic angle beam method or the magnetic particle method, otherwise such non-inspected pipe ends shall be cut off.

E.3.3.2 For pipe with $t \geq 5.0$ mm (0.197 in), ultrasonic inspection in accordance with ISO 11496 or ASTM A578 and ASTM A435 shall be used to verify that the 25 mm (1.0 in) wide zone at each pipe end is free of laminar imperfections > 6.4 mm (0.25 in) in the circumferential direction.

E.4 Radiographic inspection of weld seams

E.4.1 Radiographic technique

When applicable, radiographic inspection of the weld seam shall be conducted in accordance with ISO 12096 or ASTM E94 to image quality class R1.

E.4.2 Radiographic inspection equipment

E.4.2.1 The homogeneity of weld seams examined by radiographic methods shall be determined by means of X-rays directed through the weld material in order to create a suitable image on a radiographic film or another X-ray imaging medium, provided that the required sensitivity is demonstrated.

E.4.2.2 The radiographic films used shall be in accordance with ISO 11699-1:1998, class T2 or class T3 or ASTM E 181 5-06, class I or class II, and shall be used with lead screens.

E.4.2.3 The density of the radiograph shall be not less than 2.0 and shall be chosen such that:
a) the density through the thickest portion of the weld seam is not less than 1.5;
b) the maximum contrast for the type of film used is achieved.

E.4.3 Image quality indicators (IQIs)

E.4.3.1 Wire-type IQIs shall be used.

E.4.3.2 If ISO wire-type IQIs are used, they shall be W 1 FE, W 6 FE or W 10 FE, in accordance with ISO 19232-1:2004, and the essential wire diameters shall be as given in Table E.3 for the applicable weld thickness.

E.4.3.3 If ASTM wire-type IQIs are used, they shall be in accordance with ASTM E 747-04 and the essential wire diameters shall be as given in Table E.4 for the applicable weld thickness.

E.4.3.4 Except as allowed by E.4.3.5, the IQI used shall be placed across the weld at a location representative of full weld reinforcement and shall contain both essential wire diameters, with one being determined based upon the weld thickness with full reinforcement and the other being determined based upon the weld thickness without reinforcement.

E.4.3.5 Two IQIs may be used; one placed across the weld and the other placed on the parent metal.

	SPECIFICATION FOR BARE (ERW) & SEAMLESS LINE PIPES	DOCUMENT NO.	REV
		11-0290-02-07-02-003	0
		SHEET 29 OF 41	

Table E.3 — ISO wire-type IQI for radiographic inspection

Weld thickness ^a mm (in)	Essential wire diameter mm (in)	FE wire set	Wire number
≤ 8 (0.3)	0,16 (0.006)	W 10 to W 16	14
> 8 (0.3) to ≤ 11 (0.4)	0,20 (0.008)	W 10 to W 16	13
> 11 (0.4) to ≤ 14 (0.6)	0,25 (0.010)	W 10 to W 16 or W 6 to W 12	12
> 14 (0.6) to ≤ 18 (0.7)	0,32 (0.013)	W 10 to W 16 or W 6 to W 12	11
> 18 (0.7) to ≤ 25 (1.0)	0,40 (0.016)	W 10 to W 16 or W 6 to W 12	10
> 25 (1.0) to ≤ 32 (1.2)	0,50 (0.020)	W 6 to W 12	9
> 32 (1.2) to ≤ 41 (1.6)	0,63 (0,025)	W 6 to W 12	8
> 41 (1.6) to ≤ 50 (2.0)	0,80 (0.032)	W 6 to W 12	7
> 50 (2.0)	1,00 (0.039)	W 6 to W 12	6

^a The weld thickness is the sum of the specified wall thickness and the estimated thickness of the weld reinforcement.

Table E.4 — ASTM wire-type IQI for radiographic inspection

Weld thickness ^a mm (in)	Essential wire diameter mm (in)	Wire set	Wire identity
≤ 8 (0.3)	0,16 (0.006)	A	4
> 8 (0.3) to ≤ 11 (0.4)	0,20 (0.008)	A	5
> 11 (0.4) to ≤ 14 (0.6)	0,25 (0.010)	A or B	6
> 14 (0.6) to ≤ 18 (0.7)	0,33 (0.013)	B	7
> 18 (0.7) to ≤ 25 (1.0)	0,41 (0.016)	B	8
> 25 (1.0) to ≤ 32 (1.2)	0,51 (0.020)	B	9
> 32 (1.2) to ≤ 41 (1.6)	0,64 (0,025)	B	10
> 41 (1.6) to ≤ 50 (2.0)	0,81 (0.030)	B or C	11
> 50 (2.0)	1,02 (0.040)	C	12

^a The weld thickness is the sum of the specified wall thickness and the estimated thickness of the weld reinforcement.

E.4.4 Verification of instrument standardization

E.4.4.1 For dynamic methods at operational speeds, an image quality indicator shall be used to verify the sensitivity and adequacy of the technique on one pipe in every test unit of not more than 50 pipes, but at least once per 4 h per operating shift.

NOTE 1 Proper definition and sensitivity is attained when the essential wire diameters of the image quality indicator used are clearly visible to the operator in the applicable area (weld or parent metal).

NOTE 2 In some of the referenced ISO International Standards for non-destructive inspection, the term “calibration” is used to denote the term “standardization” as used in this International Standard.

E.4.4.2 For initial adjustment of the technique using the image quality indicator, the pipe may be held in a stationary position.

E.4.4.3 For film radiographic methods, an image quality indicator shall appear on each exposure.

EA.5 Acceptance limits for imperfections found by radiographic inspection

The size and distribution of slag-inclusion-type and/or gas-pocket-type imperfections shall not exceed the values given in Tables E.5 or E.6.



SPECIFICATION FOR BARE (ERW) & SEAMLESS LINE PIPES

DOCUMENT NO.

11-0290-02-07-02-003

REV

0

SHEET 30 OF 41

NOTE 1 The important factors to be considered in determining if imperfections are acceptable are the size and spacing of the imperfections and the sum of their diameters in an established distance. For simplicity, the distance is established as any 150 mm (6.0 in) length of weld. Imperfections of this type usually occur in an aligned pattern, but no distinction is made between aligned and scattered patterns. Also, the distribution pattern can be of assorted sizes.

NOTE 2 Unless the imperfections are elongated, it cannot be determined with assurance whether the radiological indications represent slag inclusions or gas pockets. Therefore, the same limits apply to all circular-type imperfections

E.4.6 Defects found by radiographic inspection

Cracks, lack of complete penetration and lack of complete fusion found by radiographic inspection shall be classified as defects. Imperfections found by radiographic inspection that are greater in size and/or distribution than the values given in Tables E.5 or E.6, whichever is applicable, shall be classified as defects. Pipe containing such defects shall be given one or more of the dispositions specified in Clause E. 10.

E.4.7 Traceability of radiographic images

Radiographic images shall be traceable to the applicable pipe identity.

Table E.5 — Elongated slag-inclusion-type imperfections

Maximum dimensions mm (in)	Separation (minimum) mm (in)	Number of imperfections in any 150 mm (6.0 in) length of weld (maximum)	Accumulated length of imperfections in any 150 mm (6.0 in) length of weld (maximum) mm (in)
1,6 (0.063) × 13 (0.50)	150 (6.0)	1	13 (0.50)
1,6 (0.063) × 6,4 (0.25)	75 (3.0)	2	13 (0.50)
1,6 (0.063) × 3,2 (0.125)	50 (2.0)	3	13 (0.50)

Table E.6 — Circular slag-inclusion-type and gas-pocket-type imperfections

Size mm (in)	Adjacent size mm (in)	Separation (minimum) mm (in)	Number of imperfections in any 150 mm (6.0 in) length of weld (maximum)	Accumulated diameters of imperfections in any 150 mm (6.0 in) length of weld (maximum) mm (in)
3,2 (0.125) ^a	3,2 (0.125) ^a	50 (2.0)	2	6,4 (0.25)
3,2 (0.125) ^a	1,6 (0.063)	25 (1.0)	varies	6,4 (0.25)
3,2 (0.125) ^a	0,8 (0.031)	13 (0.5)	varies	6,4 (0.25)
3,2 (0.125) ^a	0,4 (0.016)	9,5 (0.4)	varies	6,4 (0.25)
1,6 (0.063)	1,6 (0.063)	13 (0.5)	4	6,4 (0.25)
1,6 (0.063)	0,8 (0.031)	9,5 (0.4)	varies	6,4 (0.25)
1,6 (0.063)	0,4 (0.016)	6,4 (0.25)	varies	6,4 (0.25)
0,8 (0.031)	0,8 (0.031)	6,4 (0.25) ^b	8	6,4 (0.25)
0,8 (0.031)	0,4 (0.016)	4,8 (0.188)	varies	6,4 (0.25)
0,4 (0.016)	0,4 (0.016)	3,2 (0.125)	16	6,4 (0.25)

^a 2,4 mm (0.094 in) for pipe with $t \leq 6,4$ mm (0.250 in).

^b Two imperfections $\leq 0,8$ mm (0.031 in) in diameter may be as close as one diameter apart, provided that they are separated from any other imperfection by at least 13 mm (0.5 in).



SPECIFICATION FOR BARE (ERW) & SEAMLESS LINE PIPES

DOCUMENT NO.

11-0290-02-07-02-003

REV

0

SHEET 31 OF 41

E.5 Ultrasonic and electromagnetic inspection

E.5.1 Equipment

E.5.1.1 Equipment using ultrasonic or electromagnetic principles and capable of continuous and uninterrupted inspection of the weld seam of welded pipe or the outside and/or inside surface of SMLS pipe shall be used, as appropriate.

E.5.1 .2 For welded pipe, the equipment shall be capable of inspecting through the entire thickness of the weld seam as follows:

a) for EW and LW seams, the weld line plus 1.6 mm (0.063 in) of adjacent parent metal on each side of the weld line;

E.5.2 Ultrasonic and electromagnetic inspection reference standards

E.5.2.1 Each reference standard shall have its outside diameter and wall thickness within the tolerances specified for the production pipe to be inspected.

NOTE In some of the referenced ISO International Standards for non-destructive inspection, the term “tubular test piece” or “test piece” is used to denote the term “reference standard” as used in this International Standard.

E.5.2.2 Reference standards may be of any convenient length, as determined by the manufacturer.

E.5.2.3 Reference standards shall contain as reference indicators one or more machined notches or one or more radially drilled holes as given in Table E.7.

E.5.2.4 Reference indicators shall be separated in the reference standard by an amount sufficient to enable separate and distinguishable indications to be produced.

NOTE In some of the referenced ISO International Standards for non-destructive inspection, the term “reference standard” is used to denote the term “reference indicator” as used in this International Standard.

E.5.2.5 Reference standards shall be identified. The dimensions and type of reference indicators shall be verified by a documented procedure.

	SPECIFICATION FOR BARE (ERW) & SEAMLESS LINE PIPES	DOCUMENT NO.	REV
		11-0290-02-07-02-003	0
		SHEET 32 OF 41	

Table E.7 — Reference indicators

Item	Reference indicators ^a							
	Notch location		Notch orientation		Notch dimensions			Diameter of radially drilled hole ^b
	OD	ID	Longitudinal	Transverse	Depth ^c %	Length ^d (maximum) mm (in)	Width (maximum) mm (in)	
EW seam	e	e	e	f	10,0	50 (2.0)	1,0 (0.040)	3,2 (0.125)
LW seam	e	e	e	f	5,0 ^g	50 (2.0)	1,0 (0.040)	1,6 (0.063) ^g
SAW seam ^h	e	e	e	i	5,0 ^g	50 (2.0)	1,0 (0.040)	1,6 (0.063) ^g
COW seam ^h	e	e	e	i	5,0 ^g	50 (2.0)	1,0 (0.040)	1,6 (0.063) ^g
Strip/plate end seam ^h	e	e	e	i	5,0 ^g	50 (2.0)	1,0 (0.040)	1,6 (0.063) ^g
Jointer seam ^h	e	e	e	i	5,0 ^g	50 (2.0)	1,0 (0.040)	1,6 (0.063) ^g
PSL 2 SMLS pipe	e	e	j	f	12,5	50 (2.0)	1,0 (0.040)	3,2 (0.125)
PSL 1 SMLS pipe, quenched and tempered	k	k	j	f	12,5	50 (2.0)	1,0 (0.040)	3,2 (0.125)
PSL 1 SMLS pipe, other	k	f	j	f	12,5	50 (2.0)	1,0 (0.040)	3,2 (0.125)

NOTE 1 Notches are rectangular or U-shaped.

NOTE 2 For electromagnetic inspection, it might be necessary for the reference standard to contain OD notches, ID notches and a radially drilled hole. (See E.5.3.4.)

^a It is not necessary to locate reference indicators in the weld.

^b Drilled hole diameters are based upon standard drill-bit sizes. A hole is not required if a notch is used to establish the reject threshold.

^c Depth is expressed as a percentage of the specified wall thickness. It is not necessary that the depth be less than 0,3 mm (0.012 in). The depth tolerance is $\pm 15\%$ of the specified notch depth or $\pm 0,05$ mm (0.002 in), whichever is the greater.

^d Length at full depth.

^e Required.

^f Not required.

^g At the option of the manufacturer, N10 notches or 3,2 mm (0.125 in) holes may be used (see Table E.8 for applicable acceptance limits).

^h At the option of the manufacturer, for SAW and COW seams, the reject threshold may be established using weld-edge notches or weld-edge radially drilled holes.

ⁱ Either a transverse notch or a 1,6 mm (0.063 in) radially drilled hole is required.

^j At the option of the manufacturer, the notches may be oriented at an angle that would facilitate the detection of anticipated defects.

^k Required for pipe with $D \geq 60,3$ mm (2.375 in) if a notch is used to establish the reject threshold.

E.5.3 Instrument standardization

E.5.3.1 The manufacturer shall use a documented procedure to establish the reject threshold for ultrasonic or electromagnetic inspection whichever is applicable. The applicable reference indicators given in Table E1 shall be capable of being detected under normal operating conditions. Such capability shall be demonstrated dynamically, either on-line or off-line at the option of the manufacturer, using a speed of movement between the pipe and the transducer that simulates the inspection to be used for the production pipe.



SPECIFICATION FOR BARE (ERW) & SEAMLESS LINE PIPES

DOCUMENT NO.

11-0290-02-07-02-003

SHEET 33 OF 41

REV

0

E.5.3.2 The instrument shall be standardized with an appropriate reference standard (see E.5.2) at least twice per operating shift, with the second standardization being conducted 3 h to 4 h after the first to demonstrate its effectiveness and the effectiveness of the inspection procedures. Instrument standardization shall be confirmed prior to turning the unit off at the end of the inspection cycle.

NOTE In one or more of the referenced ISO International Standards for non-destructive inspection, the term ‘calibration’ is used to denote the term “standardization” as used in this International Standard.

E.5.3.3 The instrument shall be adjusted to produce well-defined indications from the applicable reference indicators when the reference standard is inspected.

E.5.3.4 If a drilled hole is used to establish the reject threshold for electromagnetic inspection of pipe with $D \geq 60.3$ mm (2.375 in) and the intended application is either the inspection of the weld seam of welded pipe or the concurrent inspection of the OD and ID surfaces of SMLS pipe, it shall additionally be verified that the equipment as so standardized produces indications, from both ID and OD notches in the reference standard, that are equal to or greater than the reject threshold established using the drilled hole.

E.5.4 Records verifying system capability

E.5.4.1 The manufacturer shall maintain NDE system records verifying the system(s) capabilities in detecting the reference indicators used to establish the equipment test sensitivity.

The verification shall cover, as a minimum, the following criteria:

- a) coverage calculation (i.e. scan plan);
- b) capability for the intended wall thickness;
- c) repeatability;
- d) transducer orientation that provides detection of defects typical of the manufacturing process [see Table E.7, Notej]);
- e) documentation demonstrating that defects typical of the manufacturing process are detected using the NDE methods described in Clause E.4 or E.5 as appropriate;
- f) threshold-setting parameters.

E.5.4.2 In addition, the manufacturer shall maintain documentation relating to

- a) NDE system operating procedures;
- b) NDE equipment description;
- c) NDE personnel qualification information;
- d) dynamic test data demonstrating the NDE system/operation capabilities under production test conditions.

E.5.5 Acceptance limits

E.5.5.1 The acceptance limit for indications produced by reference indicators shall be as given in Table E.8.

E.5.5.2 For ultrasonic inspection of welded pipe in the dynamic mode, any imperfection that produces an indication greater than the applicable acceptance limit given in Table E.8 shall be classified as a defect unless one of the following applies.

- a) Ultrasonic inspection of the imperfection in the static mode produces an indication that is less than the applicable acceptance limit given in Table E.8 and that it is ascertained that the maximum signal has been obtained.

	SPECIFICATION FOR BARE (ERW) & SEAMLESS LINE PIPES	DOCUMENT NO.	REV
		11-0290-02-07-02-003	0
		SHEET 34 OF 41	

b) It is determined that the imperfection causing the indication is a surface imperfection that is not a defect as described in 9.10.

c) For SAW and COW pipes, it is determined by radiographic inspection that the imperfection causing the indication is a slag-inclusion type or gas-pocket type of imperfection that meets the requirements of E4.5.

E.5.5.3 For SMLS pipe, any surface imperfection that produces an indication greater than the applicable acceptance limit given in Table E.8 shall be classified as a defect unless it is determined that the imperfection causing the indication is not a defect as described in 9.10.

E.5.5.4 For COW seams, any continuous indication greater than 25 mm (1,0 in) in length, regardless of the indication height, provided that it is greater than the background noise, shall be re-inspected by radiographic methods in accordance with Clause E.4 or, if agreed, other techniques.

E.5.6 Disposition of defects found by ultrasonic and electromagnetic inspection
Pipe containing defects shall be given one or more of the dispositions specified in Clause E.10.

E.5.7 Weld repair

For SAW and COW seams, defects found by ultrasonic inspection may be repaired by welding and reinspected in accordance with C.4.5. Inspection of the repair shall be performed using the same method as for the original weld.

Table E.8 — Acceptance limit

Item	Notch type	Hole size	Acceptance limit ^a
		mm (in)	(maximum) %
SAW, COW, LW or repair weld	N5	1,6 (0.063)	100
	N10	3,2 (0.125)	33
Electric weld	N10	3,2 (0.125)	100
SMLS pipe	N12,5	3,2 (0.125)	100

^a Expressed as a percentage of the indication produced by the reference indicator. The reject threshold (see E.5.3) shall not exceed the applicable acceptance limit.

E.6 Magnetic particle inspection

E.6.1 Magnetic particle inspection of SMLS pipe

E.6.1 .1 If magnetic particle inspection is used to inspect for longitudinal defects, the entire outside surface of the pipe shall be so inspected.

E.6.1.2 Surface imperfections revealed by magnetic particle inspection shall be investigated, classified and treated as follows.

a) Imperfections that have a depth 0,125t and do not encroach on the minimum permissible wall thickness shall be classified as acceptable imperfections and shall be treated in accordance with Clause C.1.

b) Imperfections that have a depth > 0,125t and do not encroach on the minimum permissible wall thickness shall be classified as defects and shall be dressed-out by grinding in accordance with Clause C.2 or shall be treated in accordance with Clause C.3.

c) Imperfections that encroach on the minimum permissible wall thickness shall be classified as defects and shall be treated in accordance with Clause C.3.

	SPECIFICATION FOR BARE (ERW) & SEAMLESS LINE PIPES	DOCUMENT NO.	REV
		11-0290-02-07-02-003	0
		SHEET 35 OF 41	

NOTE Imperfections that encroach on the minimum permissible wall thickness implies that the portion of the wall thickness that is beneath the surface imperfection is less than the minimum permissible wall thickness.

E.6.2 Equipment

The equipment used for magnetic particle inspection shall produce a magnetic field of sufficient intensity to indicate imperfections of the following character in the external surface of the pipe: cracks, seams and slivers.

E.6.3 Magnetic particle inspection reference standard

If requested by the purchaser, arrangements shall be made by the manufacturer to perform a demonstration for the purchaser's representative during production of the purchaser's order. Such a demonstration shall be based upon pipe in process or sample lengths of similar pipe retained by the manufacturer for that purpose, that exhibit natural or artificially produced defects of the character stated in E.6.2.

E.7 Residual magnetism

E.7.1 The requirements for residual magnetism shall apply only to testing within the pipe manufacturing facility.

NOTE Values of the residual magnetism of the pipe, subsequent to leaving the pipe manufacturing facility, can be affected by procedures and conditions imposed on the pipe during and after shipment.

E.7.2 The longitudinal magnetic field shall be measured on plain-end pipe with **D** 168.3 mm (6.625 in) and all smaller plain-end pipe that is inspected full length by magnetic methods or is handled by magnetic equipment prior to loading. Such measurements shall be taken on the root face or square cut face of finished plain-end pipe.

NOTE Measurements made on pipe in stacks are not considered valid.

E.7.3 Measurements shall be made using a Hall-effect gaussmeter or other type of calibrated instrument; however, in case of dispute, measurements made with a Hall-effect gaussmeter shall govern. The gaussmeter shall be operated in accordance with written instructions demonstrated to produce accurate results.

E.7.4 Measurements shall be made on each end of a pipe, selected at least once per 4 h per operating shift.

E.7.5 Pipe magnetism shall be measured subsequent to any inspection that uses a magnetic field, prior to loading for shipment from the manufacturer's facility. For pipe handled with electromagnetic equipment after measurement of magnetism, such handling shall be performed in a manner demonstrated not to cause residual magnetism in excess of the limits in E.7.6.

E.7.6 Four readings shall be taken **90 degree** apart around the circumference of each end of the pipe. The average of the four readings shall be 3,0 mT (30 Gs), and no one reading shall exceed 3,5 mT (35 Gs) when measured with a Hall-effect gaussmeter or equivalent values when measured with another type of instrument.

E.7.7 Any pipe that does not meet the requirements of E.7.6 shall be considered defective. Except as allowed by E.7.8, all pipe produced between the defective pipe and the last acceptable pipe shall be individually measured.

E.7.8 If the pipe production sequence is documented, pipe may be measured in reverse sequence, beginning with the pipe produced prior to the defective pipe, until at least three consecutively produced pipes meet the requirements.

NOTE It is not necessary to measure pipe produced prior to the three acceptable pipes.

	SPECIFICATION FOR BARE (ERW) & SEAMLESS LINE PIPES	DOCUMENT NO.	REV
		11-0290-02-07-02-003	0
		SHEET 36 OF 41	

E.7.9 Pipe produced after the defective pipe shall be measured individually until at least three consecutive pipes meet the requirements.

E.7.10 All defective pipe shall be de-magnetized full length and then their magnetism shall be re-measured until at least three consecutive pipes meet the requirements of E.7.6.

E.8 Laminar imperfections in the pipe body of EW, SAW and COW pipes

E.8.1 For EW pipe, ultrasonic inspection shall be used to verify that the pipe body is free of laminar imperfections greater than those permitted by

- a) ISO 12094:1994, acceptance level B2, if such inspection is done prior to pipe forming; or
- b) ISO 10124:1994, acceptance level B3, if such inspection is done after seam welding.

E.8.2 For SAW and COW pipes, ultrasonic inspection shall be used to verify that the strip/plate or the pipe body is free of laminar imperfections greater than those permitted by ISO 12094:1994, acceptance level B2.

E.9 Laminar imperfections along the strip/plate edges or pipe weld seam of EW, SAW and COW pipes

For EW, SAW and COW pipes, if agreed, ultrasonic inspection shall be used to verify that the 25 mm (1.0") wide zone along each of the strip/plate edges or along each side of the pipe weld seam is free of laminar imperfections greater than those permitted by

- a) ISO 12094:1994, acceptance level E2, if such inspection is done prior to pipe forming; or
- b) ISO 13663:1995, acceptance level E2, if such inspection is done after seam welding.

E.10 Disposition of pipes containing defects

Pipes containing defects shall be given one or more of the following dispositions.

- a) The defects shall be removed by grinding in accordance with Annex C.
- b) The defective areas shall be repaired by welding in accordance with Annex C.
- c) The sections of pipe containing defects shall be cut off within the applicable limits for length.
- d) The entire pipe shall be rejected.

	SPECIFICATION FOR BARE (ERW) & SEAMLESS LINE PIPES	DOCUMENT NO.	REV
		11-0290-02-07-02-003	0
		SHEET 37 OF 41	

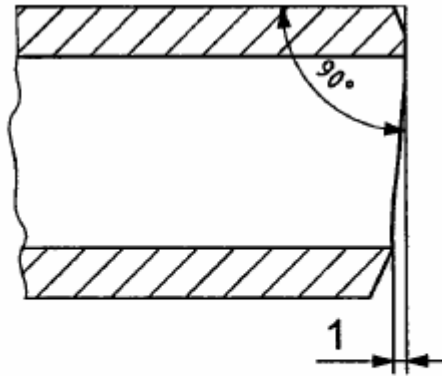
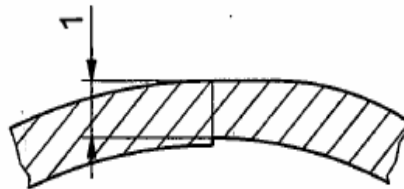

Figure 3 — Out-of-squareness



Key

- 1 remaining wall thickness at the weld

a) Radial offset of strip/plate edges of EW and LW pipes

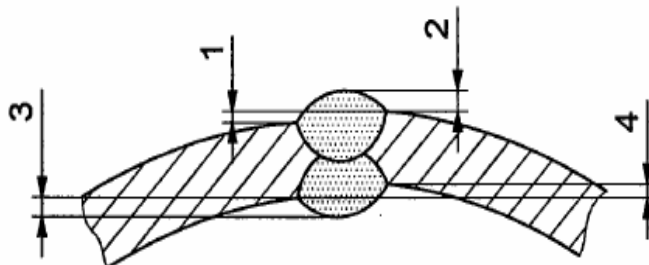

Key

- 1 outside radial offset
- 2 height of outside weld bead
- 3 height of inside weld bead
- 4 inside radial offset

b) Radial offset of strip/plate edges and height of weld beads of SAW pipe

Figure 4 — Dimensional deviations of the weld seam

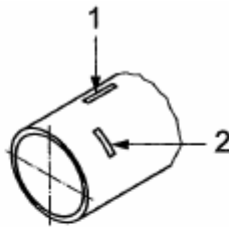

- Key**
- 1 L — longitudinal sample
 - 2 T — transverse sample

a) SMLS pipe

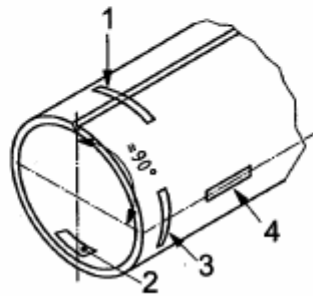

- Key**
- 1 W — transverse sample, centred on the weld
 - 2 T180 — transverse sample, centred $\approx 180^\circ$ from the longitudinal weld
 - 3 T90 — transverse sample, centred $\approx 90^\circ$ from the longitudinal weld
 - 4 L90 — longitudinal sample, centred $\approx 90^\circ$ from the longitudinal weld

b) CW, LFW, HFW, LW, SAWL and COWL pipes

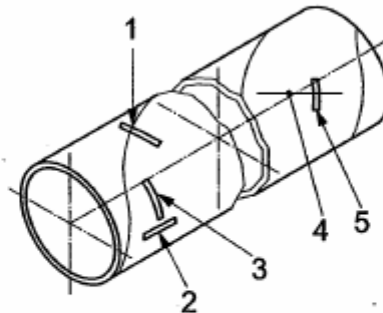

- Key**
- 1 W — transverse sample, centred on the helical seam weld
 - 2 L — longitudinal sample, centred at least $a/4$ in the longitudinal direction from the helical seam weld
 - 3 T — transverse sample, centred at least $a/4$ in the longitudinal direction from the helical seam weld
 - 4 strip/plate end weld, with length a
 - 5 WS — transverse sample, centred at least $a/4$ from the junctions of the helical seam weld and the strip/plate end weld

c) SAWH and COWH pipes

Figure 5 — Sample and test piece orientations and locations

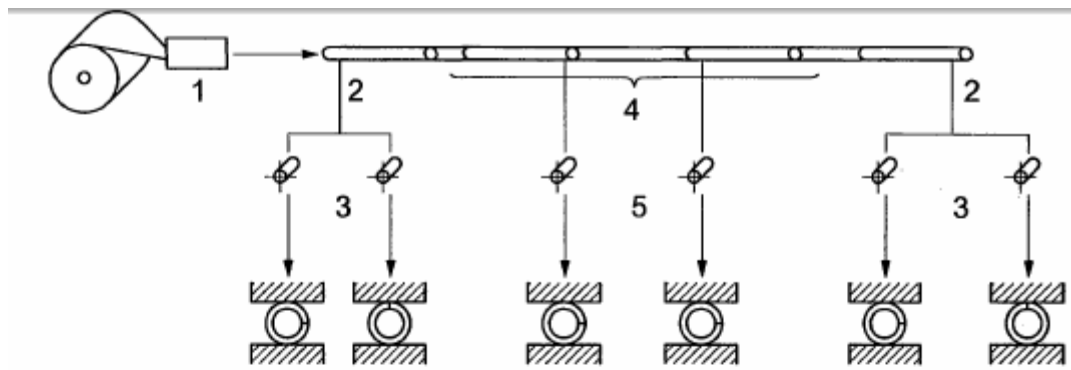

Key

- 1 welding
- 2 coil end
- 3 two test pieces from each coil end
- 4 weld stop
- 5 two test pieces, one from each side of the weld stop

a) EW pipe in grades \geq L245 or B and LW with $D < 323,9$ mm (12.750 in) — Non-expanded, produced in multiple lengths

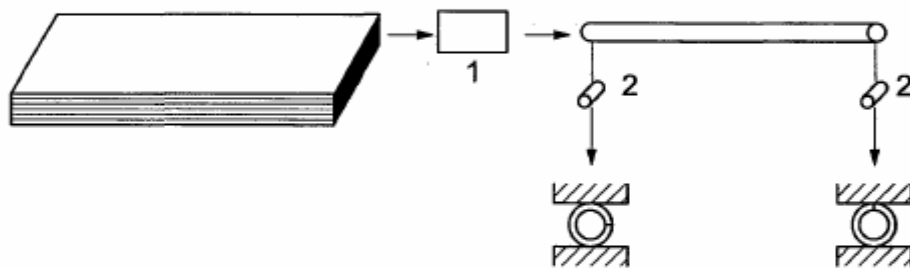

Key

- 1 welding
- 2 two test pieces, one from each pipe end

b) EW pipe in grades \geq L245 or B — Non-expanded, produced in single lengths

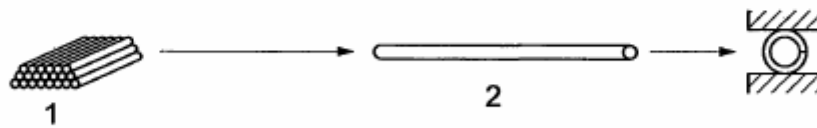

Key

- 1 test unit of \leq 50 tonnes (55 tons) of pipe
- 2 one test piece, from one pipe end

c) EW pipe in grades L175, L175P, A 25 or A 25P with $D \geq 73,0$ mm (2.875 in)



Key

- 1 test unit of \leq 100 lengths of pipe
- 2 one test piece, from one pipe end

d) EW pipe in grades \geq L245 or B and LW pipe with $D < 323,9$ mm (12.750 in) — Cold expanded

Figure 6 — Flattening tests

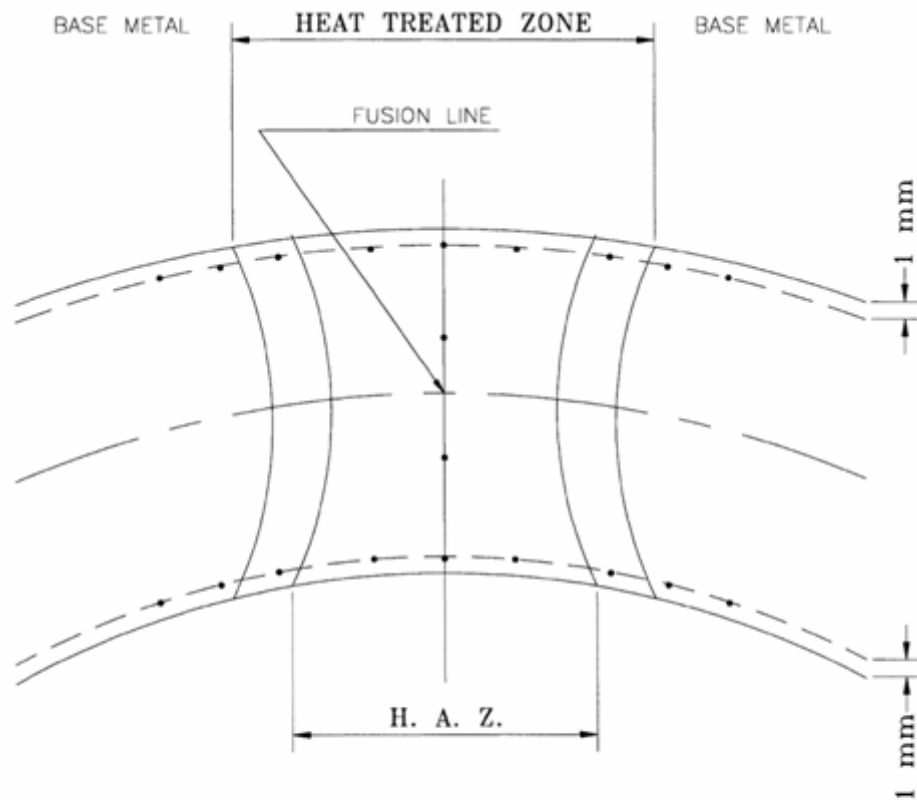

H.A.Z. HEAT AFFECTED ZONE

Figure 10 - LOCATIONS FOR HARDNESS MEASUREMENT



GAIL GAS LIMITED
CITY GAS DISTRIBUTION PROJECT



SPECIFICATION FOR 3 LPE COATING

CLIENT JOB NO.

-

TOTAL SHEETS

29

DOCUMENT NO

11

0290

02

07

02

004

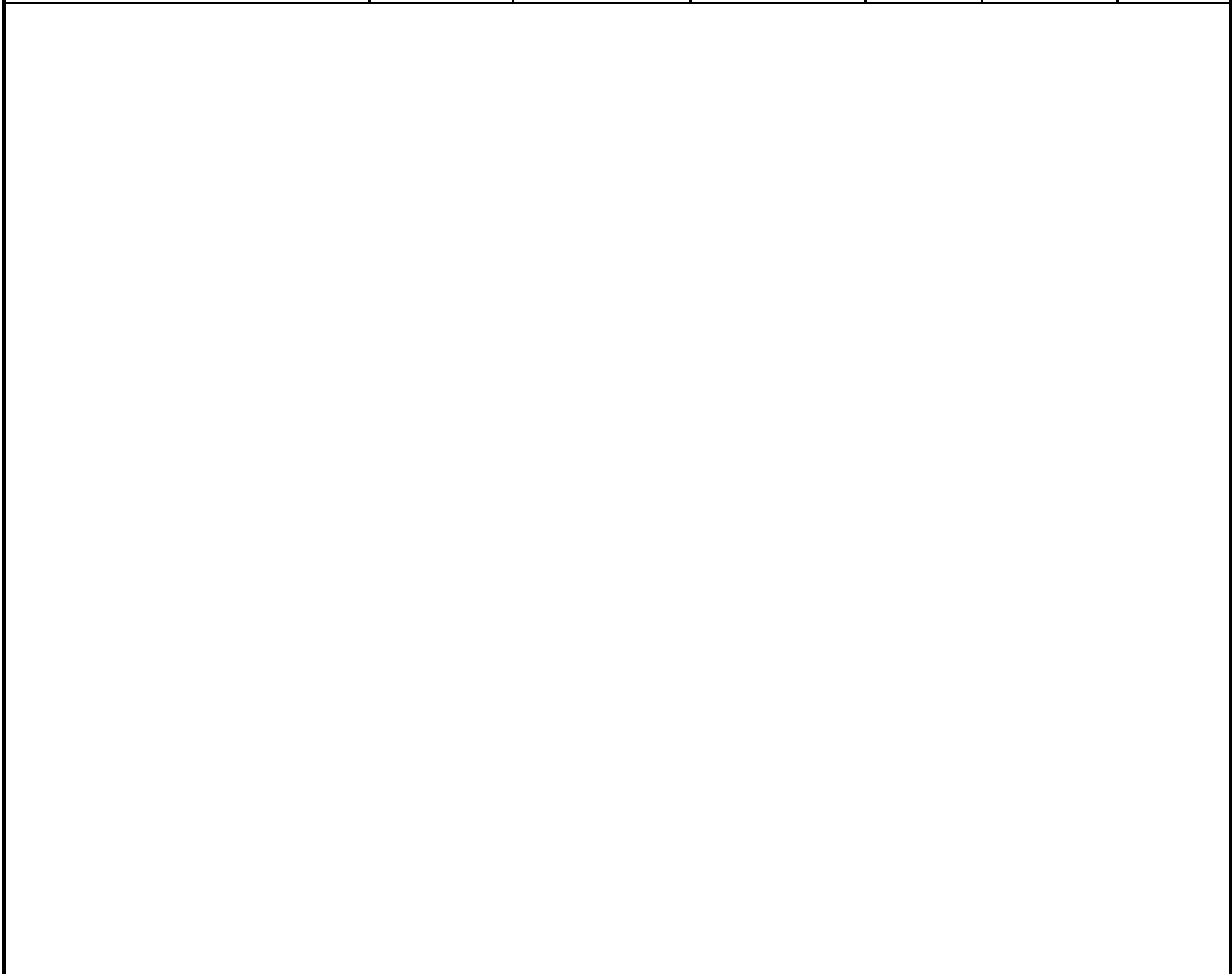

REV	DATE	DESCRIPTION	PREP	CHK	APPR
0	4.11.09	ISSUED FOR CLIENT COMMENTS	MH	SB	SB
A	29.10.09	ISSUED FOR IDC	MH	SB	SB

CONTENTS

1	GENERAL.....	2
2	CODES, REGULATIONS AND STANDARDS.....	3
3	REFERENCE DOCUMENTS.....	4
4	DOCUMENT PRECEDENCE	4
5	SPECIFICATION DEVIATION / CONCESSION CONTROL	5
6	QUALITY ASSURANCE / QUALITY CONTROL.....	5
7	MATERIAL AND APPLICATION	5
8	HANDLING AND STORAGE OF MATERIALS	5
9	COATING MATERIALS.....	7
10	COATING PROCEDURE.....	13
11	CLEANING AND SURFACE PREPARATION.....	13
12	COATING.....	15
13	INSPECTION AND TESTING.....	16
14	DOCUMENTATION	21

	SPECIFICATION FOR 3LPE COATING FOR LINE PIPE	DOCUMENT NO.	REV
		11-0290-02-07-02-004	0
		SHEET 2 OF 29	

1 GENERAL

Wood Group Engineering India (P) Ltd. (WGEIL) has been engaged as Project Management Consultancy (PMC) for the City Gas Distribution Pipeline Project of Gail Gas Limited (GGL).

Wood Group Engineering India (P) Ltd. has been contracted to provide Design, Procurement services construction Management to meet the earliest possible start-up date for the development.

1.1 Introduction

This specification defines the minimum technical requirements for the application of three-layer polyethylene coating to the external surface of the pipe for buried service from ambient temperature to 60°C.

1.2 Purpose

This specification supplements the codes listed in Section 2.0 of this document.

1.3 Definitions

For this specification the following definitions shall apply:

OWNER	-	Gail Gas Limited (GGL)
CONSULTANT	-	Wood Group Engineering India (P) Ltd. (WGEIL)
CONTRACTOR	-	The Company named as such in the deed.
SHALL/MUST/ISTO BE	-	A mandatory requirement
SHOULD	-	A non-mandatory requirement, advisory or recently Amended

1.4 Abbreviations

ASTM	-	American Society for Testing and Materials
BS	-	British Standards
DIN	-	Deutsche Industrie Normen
FBE	-	Fusion Bonded Epoxy
ISO	-	International Organisation of Standardization
NACE	-	National Association of Corrosion Engineers
SSPC	-	Steel Structures Painting Council

2 CODES, REGULATIONS AND STANDARDS

The latest edition of the following codes and standards shall establish the minimum standards for the work. VENDOR may use alternate standards that meet or exceed those if approved by OWNER.

American Society for Testing and Materials (ASTM)

- ASTM D 638 Test Methods for Tensile Properties of Plastics

JP KENNY



SPECIFICATION FOR 3LPE COATING
FOR LINE PIPE

DOCUMENT NO.

REV

11-0290-02-07-02-004

0

SHEET 3 OF 29

Page 64 of 100

- ASTM G95 Test Method for Cathodic Disbonding of Pipeline Coatings.

International Standards Organization (ISO)

- ISO 9002 Quality System – Quality Assurance in Production, Installation and Servicing
- ISO 8501-1 Preparation of Steel Substrates before Application of (Part I) Paints and Related Products – Visual Assessment of Surface Cleanliness
- ISO 8503-1 Preparation of Steel Substrates before Application of (Part 1) Paints and Related Products – Visual Assessment of Surface Cleanliness

British Standards (BS)

- BS 5750 Specification for Final Inspection and Testing (Part 3)

Deutsche Institute Fur Normung (DIN)

- DIN 30670 Polyethylene Coatings for Steel Pipes and Fittings
- DIN 50049 Inspection Documents for the Delivery of Metallic Products.

3 REFERENCE DOCUMENTS

The following documents are part of this specification:

- Appendix 1 Inspection Summary for Procedure Qualification Test PE – Coating for All pipe diameter.
- Appendix 2 Inspection summary for production testing on full PE – coating system for All pipe diameter
- Appendix 3 Air Entrapment Assessment
- Appendix 4 Flexibility Test for FBE Layer Coating PQT
- Appendix 5 Hot Water Resistance Test for FBE layer Coating PQT.
- Appendix 6 List of Approved Vendors

4 DOCUMENT PRECEDENCE

The VENDOR shall notify OWNER / CONSULTANT of any conflict between this specification, the related data sheets, the Codes and Standards and any other specifications noted herein. Resolution and / or interpretation precedence shall be obtained from OWNER / CONSULTANT in writing before proceeding with the design & manufacture.

In case of conflict, the order of precedence shall be:

- Equipment Data Sheets
- Equipment Narrative Specification
- Design General Specification and Standards
- Industry Codes and Standards

	SPECIFICATION FOR 3LPE COATING FOR LINE PIPE	DOCUMENT NO.	REV
		11-0290-02-07-02-004	0
		SHEET 4 OF 29	

5 SPECIFICATION DEVIATION / CONCESSION CONTROL

Any technical deviations to the Specifications and its attachments including, but not limited to, the Data Sheets and narrative Specifications shall be obtained by the VENDOR only through CONCESSION REQUEST format. CONCESSION REQUESTS require OWNER / CONSULTANT review / approval prior to implementation of the proposed changes. Technical changes implemented prior to OWNER / CONSULTANT approval are subject to rejection.

6 QUALITY ASSURANCE / QUALITY CONTROL

A copy of the VENDOR's QA/QC program shall be submitted to the OWNER / CONSULTANT with its quotation for review and concurrence prior to award. If VENDOR's QA/QC program is ISO 9000 certified, then only a copy of the ISO 9000 certificate is required. In addition, if VENDOR's facility is ISO certified, QA audit requirements will be waived in favour of ISO 9000 registrar audits, unless the OWNER / CONSULTANT trend analysis program indicates areas of concern.

7 MATERIAL AND APPLICATION

7.1 Coating Contractor shall submit a detailed written description of the coating equipment, procedure and materials for OWNER / CONSULTANT review. The description shall be accompanied by full details and results of tests on similar coating, or trials performed by Coating Contractor, which document the quality of the finished coating. Such test results and / or trails shall demonstrate, to the satisfaction of OWNER / CONSULTANT, that coating contractor equipment, procedures and materials can supply a finished coating meeting the requirements of this specification

7.2 The description of the coating procedure shall include:

- Pipe handling procedure and storage
- Pipe cleaning, including acid washing (phosphating)
- Pipe pre-heating
- Chromate washing and FBE application method
- Adhesive application method
- Testing and inspection
- Quality Control
- Repair procedures

The equipment description shall cover all pipe handling, cleaning, coating, testing and inspection equipment to be used. Details of all materials to be used for pipe coating shall be provided.

7.3 VENDOR shall confirm by his experience and test data, demonstrating to the satisfaction of OWNER / CONSULTANT that specified thickness of the coating system will meet the requirements of this specification.

8 HANDLING AND STORAGE OF MATERIALS

8.1 Acceptance of Pipe

8.1.1 Pipe furnished by OWNER / EPC Contractor and received by coating contractor shall be deemed to be in the custody of coating contractor from the time of receipt until returned to OWNER / CONSULTANT.

8.1.2 Coating contractor shall inspect and accept responsibility for each length of line pipe and other VENDOR supplied material, immediately on receipt, with the exception of defective materials that cannot be detected until after blast cleaning.

8.1.3 All pipes shall be checked for bevel damage, weld seam heights, dents, gouges, laminations and flat ends, corrosion and other damage. Defects noted shall be recorded by Coating contractor and witnessed by OWNER / CONSULTANT representative. Inspection of bare pipe for laminations and other steel defects will not be performed until after blast cleaning.

	SPECIFICATION FOR 3LPE COATING FOR LINE PIPE	DOCUMENT NO.	REV
		11-0290-02-07-02-004	0
		SHEET 5 OF 29	

8.1.4 Bevel protectors shall be removed before the pipe travels through the coating plant and replaced with same or new caps after the pipe is coated.

8.1.5 Damage caused to pipe while in the custody of coating contractor shall be reported to OWNER / CONSULTANT and repaired by Vendor to the satisfaction of OWNER / CONSULTANT representative. The cost of such repair work and the cost of any material lost shall be borne by VENDOR.

No repair work shall proceed until a written procedure has been prepared by vendor and approved by OWNER / CONSULTANT.

8.1.6 Identification marks stencilled on the pipe shall be recorded by Coating contractor before commencement of surface preparation. Coating contractor shall mark a unique reference number on the inside of the pipe for tracking during coating operations. Certification documents accompanying the pipes shall be preserved by coating contractor.

8.1.7 All pipes shall be checked for external and internal contamination for items such as oil, grease, temporary coatings, chlorides or other substances, which may affect the blast cleaning plant.

Upon delivery to the coating factory or storage area, all pipes shall be examined for condition and damage shall be notified in writing to OWNER / CONSULTANT.

8.2 Pipe Handling

8.2.1 Pipe shall be handled in a manner to prevent damage to the pipe and its coated surfaces.

8.2.2 End hooks suitably radiused and lined with plastic or similar approved material or a forklift with suitably padded forks shall be used to pick up pipe. A spreader bar shall be used between lifting lines. During handling the pipe shall be prevented from impacts or jars. Vendor representative shall be advised of any pipe suffering impact or jars.

Lifting equipment shall be OWNER / CONSULTANT approved. Wire ropes shall not be used in direct contact to lift pipes.

8.3 Pipe Stacking

8.3.1 Pipe shall be stacked in such a manner so as to prevent damage to the pipe or coating. Prior to use Coating contractor shall submit proposed stacking arrangements, including stacking heights, to OWNER / CONSULTANT for review.

8.3.2 All pipes shall be stacked on level ground free from foreign materials, stones and vegetation and on supports of a proven load bearing capacity. Pipes shall be suitably spaced from the soil (minimum 150 mm) to prevent any contact with the ground and to prevent surface water from entering during the entire storage period. Pipe shall be prevented from exposure to salt spray.

8.3.3 Separation between coated pipe joints shall be proved by the use of strips of soft rubber, rope or their material, which will prevent damage to the coating. Pipe stacks shall be of the same diameter, wall thickness and grade of pipe and shall be clearly marked.

8.3.4 Slings or non-metallic straps shall be used for securing loads during transportation. They shall be suitably padded at contact points with the pipe.

8.4 Damage to Pipe Ends

8.4.1 All major damage to pipe ends / bevels, including dents or gouges shall be repaired by removal of damaged pipe material and rebeveling. No welding on the pipe surface shall be allowed.



SPECIFICATION FOR 3LPE COATING FOR LINE PIPE

DOCUMENT NO.

REV

11-0290-02-07-02-004

0

SHEET 6 OF 29

Page 67 of 100

Minor damage to pipe ends / bevels may be repaired by grinding. Minor damage shall mean damage that is not over 0.025 inch in depth and the number of such damages is not more than 3 per pipe. The OWNER / CONSULTANT representative shall be consulted for damage deeper than 0.025 inch.

8.4.2 Repair by grinding on the pipe ends / bevels outside diameter shall not reduce the wall thickness to less than the minimum requirements of pipes specification when measured using ultrasonic thickness measurement equipment and provided the hardness does not exceed specified limits.

8.4.3 Pipe identification numbers shall be preserved during repair and due allowance for cut off ends shall be made in the tally of pipe lengths returned to VENDOR.

8.4.4 Any reduction in pipe lengths shall be input to COATING Contractor pipe tracking system.

8.5 Material Control Records

8.5.1 Coating contractor shall record the receipt, issue return or disposal of all materials supplied by Vendor and shall permit inspection of those records by Vendor at all reasonable times. In particular, the records shall reference the pipe number of each pipe.

8.5.2 Coating contractor shall submit details of material control recording procedure to OWNER / CONSULTANT review and approval.

8.5.3 Coating contractor shall submit details of his traceability procedure for OWNER / CONSULTANT review and approval.

8.6 Handling and Storage of Coating Materials

8.6.1 Material used for coating provided by COATING CONTRACTOR shall be clearly marked with the following details :-

- Name of manufacturer
- Material Identification
- Batch Number
- Date of Manufacture
- Quantity
- Manufacturing Standard

8.6.2 Materials shall be handled and stored in accordance with applicable safety regulations and the material manufacturer's recommendations and shall be used according to the manufacturer's batch sequence.

8.6.3 The containers or packages of materials shall be properly handled in order to avoid damage.

8.6.4 Coating materials should be stored in a clean, dry place at ambient temperatures.

9 COATING MATERIALS

9.1 General

9.1.1 The pipe coating procedure shall consist of the following :-

- Blast Cleaning
- Chemical pre-treatment
- Chromate pre-treatment

	SPECIFICATION FOR 3LPE COATING FOR LINE PIPE	DOCUMENT NO.	REV
		11-0290-02-07-02-004	0
		SHEET 7 OF 29	

- Application of Fusion Bond Epoxy (FBE) layer
- Application of adhesive layer
- Application of Polyethylene (PE) layer

COATING CONTRACTOR shall supply 2 copies of all test records and certification listed in Section 9.2 through 9.4 of this document for approval of OWNER / CONSULTANT prior to start of coating operations.

COATING CONTRACTOR shall consume coating materials on first in first out basis.

9.1.2 The manufacturer's trade name and data sheets for each coating material proposed by the COATING CONTRACTOR shall be submitted for OWNER / CONSULTANT approval prior to the placing of any order for coating work.

9.1.3 The coating materials shall be handled stored and applied in accordance with the manufacturer's specifications or as directed by an authorised representative of the coating manufacturer.

9.2 FBE Powder

9.2.1 All packages of powder shall be marked with the following data as a minimum.

- Manufacturer
- Material identification
- Batch number
- Place and date of manufacture
- Expiry date
- Healthy safety and environment instructions
- Storage instructions (storage shall normally be at a temperature not greater than 25 Deg.C).
- Material not supplied with the above information shall not be used.
- MSDS

9.2.2 A production batch is assumed to be a quantity of powder produced from one charge of the extruder. No container shall contain powder from more than one batch.

9.2.3 The COATING CONTRACTOR shall obtain the manufacturer's test records for typical results of the following data :

Cathodic disbondment – 28-day test @ 20 and 60 Deg.C shall be witnessed by Independent Inspection Agency:

- Sieve analysis
- Gel time
- Infrared scan
- Density
- Moisture content
- Thermal analysis (including glass transition temperature)
- Adhesion
- Impact resistance
- Hardness
- Flexibility
- Dielectric breakdown voltage
- Abrasion resistance
- Penetration resistance
- Volumetric electrical resistivity
- Thermal shock resistance
- Thermal conductivity
- Water absorption

	<p align="center">SPECIFICATION FOR 3LPE COATING FOR LINE PIPE</p>	DOCUMENT NO.	REV
		11-0290-02-07-02-004	0
		SHEET 8 OF 29	

- Water vapour transmission
- Salt spray resistance
- Hot water resistance
- Cathodic disbondment
- Strain polarization cracking
- Cure (by glass transition temperature)
- Stability

9.2.4 Each FBE batch shall be accompanied by a certificate (EN 10204 TYPE 3.1B, or equivalent) stating the following tests have been carried out on every batch and results are in accordance with the manufacturer's product specifications :

- Sieve analysis
- Gel time
- Infrared scan
- Density
- Moisture content
- Thermal analysis

9.2.5 For each batch of powder, the COATING CONTRACTOR shall in the presence of the OWNER / CONSULTANT representative, take three half kilogram samples of powder.

One sample shall be given to the OWNER / CONSULTANT representative; one sample shall be stored by the COATING CONTRACTOR at a temperature not to exceed 20 Deg.C for a period to be agreed upon between the OWNER / CONSULTANT and COATING CONTRACTOR.

9.2.6 The third sample shall be used by the COATING CONTRACTOR to check the stability of the powder by measuring the following properties using the same methods as the manufacturer :

- Gel / cure time
- Sieve analysis
- Flexibility
- Impact resistance
- Adhesion
- Density
- Moisture content
- Thermal characteristics

Test shall be carried out in the presence of OWNER / CONSULTANT at the coating yard at least one week prior to its use. Flexibility, Impact Resistance & Adhesion Test shall be carried out on coated pipes. In case Coating Contractor does not have the facility to conduct any of the test in-house, Coating Contractor shall carry out the tests in a reputed lab with prior approval of Owner / Consultant and will submit the test results for review of owner / consultant.

9.2.7 The COATING CONTRACTOR shall ensure that the tests on a detached coating film, as defined below, are carried out by the epoxy powder manufacturer once per year or each time a powder formulation change is made.

The tests shall be carried out on detached coating samples which have been prepared by application on 6mm thick PTFE coated polished steel plates.

9.2.7.1 Micro-Sectioning

A cross section of the cured film shall be examined at a magnification of X100. The film shall be homogenous and essentially free of voids or other defects.

9.2.7.2 Tensile Strength / Elongation

Test specimens shall be tested at a strain rate of 1mm/min. Values for tensile strength shall be quoted as maximum strength and strength at break, as well as the elongation at "yield" and "break".

	SPECIFICATION FOR 3LPE COATING FOR LINE PIPE	DOCUMENT NO.	REV
		11-0290-02-07-02-004	0
		SHEET 9 OF 29	

9.2.7.3 Dielectric Strength

The dielectric strength and dielectric test method of the cured material shall be quoted by the manufacturer. Units of dielectric strength shall be kilovolt per millimetre.

9.2.7.4 Water Permeability

The water permeability and permeability test methods of the cured material shall be specified by the manufacturer. Units of water permeability shall be gram per 24 hour per meter squared per meter thickness together with the test method.

9.2.7.5 Water Absorption

The quantity of water absorbed after a 3-month's immersion test at 20 Deg.C shall be quoted by the manufacturer.

9.3 Adhesive

The adhesive layer shall be polyethylene copolymer, which shall provide sufficient adhesion between the FBE corrosion coating and the polyethylene coating. The adhesive layer shall have the following characteristics:

PROPERTIES	TEST METHODS	UNIT OF MEASURE	LIMITS
Melt Flow Index (190 Deg.C / 2.16 kg)	ASTM D 1238	G/10min.	1.0 (min.)
Softening point	ASTM D 1525	Deg.C	100 (min.)
Density at 23 Deg.C.	ASTM D 1505	G/cm3	0.92 (min.)
Tensile yield strength at 23 Deg.C.	ASTM D 1238	Nmm3	>15
Ultimate elongation at 23 Deg.C	ASTM D 638	%	>850

9.3.1 COATING CONTRACTOR shall provide details of type and properties of the adhesive layer for the OWNER / CONSULTANT approval.

9.3.2 COATING CONTRACTOR shall obtain the manufacturer's production test records for each batch of adhesive giving the following data :

- Water absorption
- Water vapour transmission
- Shelf Life
- Adhesion to FBE and polyethylene layers at 25 Deg.C and 60 Deg.C
- Density
- Melt flow index

9.3.3 The COATING CONTRACTOR shall test one batch in every ten for compliance with the manufacturer's certificates described in Section 9.3 for adhesion, density and melt flow index.

In addition to manufacturer's certificate, the COATING CONTRACTOR shall draw samples from each batch of adhesive in the presence of OWNER/ CONSULTANT and test the following properties at the



SPECIFICATION FOR 3LPE COATING FOR LINE PIPE

DOCUMENT NO.

REV

11-0290-02-07-02-004

0

SHEET 10 OF 29

Page 71 of 100

coating yard at least one week prior to its use, to establish compliance with the manufacturer's certificates:

- Specific gravity
- Melt Flow Rate
- Vicat Softening point

9.4 Polyethylene Material

The polyethylene shall be suitable for use up to design temperatures of the pipeline and suitable for a 3-layer coating system, and shall match the following properties.

S.No.	Properties	Units	Requirements	Test Method
a.	Tensile Strength @ +25 Deg.C	N/mm 2	17 (min.)	ASTM D 638
b.	Melt Flow Rate (190 Deg.C/2.16 kg)	G/10 minute	0.25 (min.)	ASTM D 1238 OR DIN 53735
c.	Specific Gravity @ +25 Deg.C	-	0.941(min.) (HDPE)	ASTM D 792
d.	Hardness @ +25 Deg.C	Shore D	50 (min.)	ASTM D 2240
e.	Water absorption, 24 hours, @ +25 Deg.C	%	0.05 (max.)	ASTM D 570
f.	Volume Resistivity @ 25 Deg.C.	Ohm- cm	10 ¹⁵ (min.)	ASTM D 257
g.	Dielectric withstand, 1000 Volt / sec rise @ +25 Deg.C	Volts / mm	30,000 (min.)	ASTM D 149
h.	Vicat Softening Point	Deg.C	110 (min.)	ASTM D 1525
i.	Elongation	%	600 (min.)	ASTM D 638
j.	Oxidative Induction Time in Oxygen at 220 Deg.C, Aluminium pan, on screen	Min.	10	ASTM D 3895
k.	Environmental Stress Crack Resistance (ESCR) (for F 50 Medium Density Condition "C" High Density, Condition "B")	Hours	300 300	ASTM D 1693
i.	Carbon Black Content	%	2 (min.)	ASTM D 1603

- The data, information and suggestions contained herein are given purely as a guide.

NOTE: Tests performed on compression-moulded plaques made as per ASTM D 1928 Procedure C.

- Dielectric Strength 220kVlcm
- Carbon Content 2.18%
- Melting Point (ASTM D 3417) 129Deg.C
- Penetration – Probe Dia. 6.35 mm
- Sample thk. Lmm (ASTM G17)

9.4.1 The COATING CONTRACTOR obtain from the manufacturer the following data/detail for each batch of material :

- Density
- Melt Flow Index
- Shore Hardness
- Elongation



SPECIFICATION FOR 3LPE COATING FOR LINE PIPE

DOCUMENT NO.

REV

11-0290-02-07-02-004

0

SHEET 11 OF 29

- Tensile Strength
- Melting Point
- Dielectric breakdown voltage (one off declaration)
- Environmental stress cracking resistance (one off declaration)
- Brittleness temperature (one off declaration)

Manufacturer shall supply test results for Thermal Ageing and Ultra Violet Radiation as per DIN 30670. The COATING CONTRACTOR shall test one batch in every ten for compliance with the manufacturer's certificates described in Section 9.3.

In addition to manufacturer's certificate, the COATING CONTRACTOR shall draw samples from each batch of PE in the presence of OWNER / CONSULTANT and test the following properties at the coating yard at least one week prior to its use, to establish compliance with the manufacturer's certificates:

- Melt Flow Rate
- Specific Gravity
- Vicat Softening Point
- Moisture Content
- OIT

The coating must be able to withstand a maximum in service operating temperature of +60 Deg.C and shall confirm to "S" type of coating as per DIN 30670. In addition, in open storage the coating must be able to withstand a temperature of at least +80 Deg.C., without impairing its serviceability and properties specified. The following requirement of coating system of coating system may be specified, as being done in other OWNER tenders:

Sr.N	Properties	Units	Requirement	Test Method
a.	Bond Strength (Using Type 2 Test Assembly i.e. Dynamometer) @ 20 +/- 5 Deg.C @ 65 +/- 5 Deg.C.	Kg/cm	8.0(min.) 5.0(min.)	DIN 30670
b.	Impact Strength (Min. of 30 impacts on body along the length. No when tested at 25 kV)	Joules per mm of coating thickness	7 (min.)	DIN 30670
c.	Indentation Hardness @ 23 +/- 2 Deg.C @ 70 +/- 2 Deg.C	Mm	0.2 (max.) 0.3 (max.)	DIN 30670
d.	Elongation at Failure	%	300 (min.)	DIN 30670
e.	Coating Resistivity (*)	Ohm-m2	10 ⁸ (min.)	DIN 30670
f.	Heat Ageing (*)	-	Melt flow rate shall not deviate by more than 35% of original value	DIN 30670
g.	Light Ageing (*)	-	Melt flow rate shall not deviate by more than 35% of original value	DIN 30670
h.	Cathodic Disbondment @ 65 Deg.C after 30 days @ 65 Deg.C after 48 hours	mm radius of disbondment	15 max. 7 max.	ASTM G 42



SPECIFICATION FOR 3LPE COATING FOR LINE PIPE

DOCUMENT NO.

REV

11-0290-02-07-02-004

0

SHEET 12 OF 29

Sr.No	Properties	Units	Requirement	Test Method
		(**)		
i.	Degree of cure of Epoxy Percentage cure, H Tg	% , Deg.C	95 +3/-2	CSA Z 245 20-98 (***)

(*) Test carried out in an independent laboratory of national / international recognition on PE top coat is also acceptable.

(**) Disbondment shall be equivalent radius of total unsealed area as per ASTM G42.

(***) Temperature to which the test specimens are to be heated during cyclic heating shall however be as per the recommendations of epoxy powder manufacturer

9.4.2 The COATING CONTRACTOR shall provide the information detailed in Section 9.2.4 for the OWNER / CONSULTANT approval prior to the start of coating operations.

10 COATING PROCEDURE

The pipe coating procedure shall consist of the following :

- Blast cleaning
- Chemical pre-treatment
- Chromate pre-treatment
- Application of Fusion Bond Epoxy (FBE) layer
- Application of adhesive layer
- Application of Polyethylene (PE) layer

11 CLEANING AND SURFACE PREPARATION

11.1 Inspection Before Cleaning

Pipes shall be inspected for corrosion in accordance with ISO 8501 Part 1. Pipes in conditions A and B only shall be accepted for coating.

11.2 Cleaning Prior to Blast Cleaning

11.2.1 Before the blast cleaning, all surface contaminants such as oil, grease, tar, salt or other contaminants on the pipe shall be removed by solvent cleaning (xylo-mineral spirits or similar) followed by steam or hot bath cleaning.

11.2.2 A OWNER / CONSULTANT approved salt meter shall be used to carry out salt tests before washing and after blast cleaning (after first blast if two blast system is used). One test shall be carried out at each end and one at the centre of the pipe. The frequency of the salt testing shall be agreed upon between the COATING CONTRACTOR and the OWNER / CONSULTANT.

The salt test meter shall be calibrated and used in accordance with the manufacturer's recommendation. The acceptance criteria shall not exceed 5 micrograms per centimetre square before blasting and 2 micrograms per centimetre after blasting.

11.2.3 The water break test shall be used to check oil contamination.

11.3 Surface Preparation

11.3.1 After cleaning and prior to abrasive blasting the pipeline shall be uniformly heated to 65-85 Deg.C to remove all moisture and preclude any condensation of moisture on the pipe after blast cleaning.



**SPECIFICATION FOR 3LPE COATING
FOR LINE PIPE**

DOCUMENT NO.

REV

11-0290-02-07-02-004

0

SHEET 13 OF 29

11.3.2 Ends of the pipe shall be fitted with plugs so as to prevent entry of abrasive into the pipe during the blast cleaning operation. Alternatively the COATING CONTRACTOR may link the pipes together to prevent entry of abrasive.

11.3.3 Using dry blasting techniques only, the exterior surface of the pipe joints shall be abrasively cleaned to remove all mill scale and other impurities from the surface.

Twin head abrasive blasting machines shall be used. The abrasive shall be G24 to G50 steel grit to provide the specified anchor pattern. A combination of grit mixed with S280 or S330 steel shot to remove mill scale and other surface impurities is acceptable. The use of sand is not permitted.

Blasting abrasive shall be kept dry, clean and free from contamination. When recovered metallic grit systems are used, a stabilized working mix of blast cleaning material shall be established and maintained by frequent small additions from fresh or cleaned stock at a rate sufficient to replenish consumption. Large additions of new material shall be avoided. Blasting and other dust producing areas shall be kept separate from coating application areas.

No blast cleaning shall take place when the prevailing relative humidity is greater than 85 percent unless pipe is preheated to at least 3 Deg.C above the dew point or 25 Deg.C whichever is greater.

11.3.4 The surfaces of the pipes shall be blasted until a finish of ISO 8501-1 Sa 2.1/2 (Steel condition A or B) is attained.

11.3.5 The surface profile (anchor pattern) shall be between 50 and 100 microns.

11.3.6 The blast cleaned surface shall not be contaminated with dirt, dust, metal particles, hydrocarbons, water, chlorides, sulphates or any other foreign matter, which would be detrimental to the coating. If pipe was varnish coated, it shall be checked with magnifying glass (X30) to confirm no residues of varnish remain in the anchor pattern valleys.

11.3.7 Prior to the coating application, the exterior surface shall be thoroughly inspected under adequate lighting. All surface imperfections such as silvers, scabs, burrs, gouges or sharp edge defects, shall be removed by chiselling or grinding.

11.3.8 Any pipe length containing a dent shall be set-aside for the OWNER / CONSULTANT representative to determine its disposition. Gouges in a dent shall not be ground without OWNER / CONSULTANT approval.

11.3.9 Pipes with chiselled and ground areas greater than 25mm diameter shall be reblasted to meet the requirements as specified in Sections 11.3.4 and 11.3.5.

11.3.10 No grinding shall be permitted which reduces the wall thickness of the pipe except as stated in Section 9.4.

11.3.11 Any dust or loose residue that has accumulated during blasting and / or grinding operations shall be removed by the use of clean compressed air or vacuum extraction. Alternative methods for removing dust and lint shall require approval of OWNER / CONSULTANT.

11.3.12 The total elapsed time between the start of blasting of any pipe and the heating of that pipe to the specified temperature shall not exceed the following time humidity table :

Percent Relative Humidity	Elapsed Time Hours
85	0.5
80	1.0
70	1.5
60	1.75
50	2.0

	SPECIFICATION FOR 3LPE COATING FOR LINE PIPE	DOCUMENT NO.	REV
		11-0290-02-07-02-004	0
		SHEET 14 OF 29	

Any pipe surface not processed within the above time humidity table shall be completely reblasted before coating.

11.4 Chemical Pre-treatment

- 11.4.1 Before application of epoxy powder, the surface to be coated shall be heated to a temperature of 120 to 150 Deg. F (49 to 66 Deg.C), spray washed with a solution of Oakite 31 / “Oakite 33 (phosphoric acid) and spray rinsed with clean hot water 160 to 180 Deg. F (71 to 82 Deg.C) to remove all acid residue.
- 11.4.2 A uniform pH of 1 or less shall be maintained over the entire surface of the treated area.
- 11.4.3 Treatment time shall be a minimum of 20 seconds with the pipe surface temperature between 45-75 Deg C.
- 11.4.4 High pressure water rinse at 500 to 1000 psi (35 to 67 Bar) will be used to remove any treatment residue. A minimum of 22 gallons of fresh water per 100 square feet of pipe surface should be used (10L/m2). The wetted surface of the rinsed pipe shall have a pH of 6 or greater. Water must be potable with less than 200 ppm total dissolved solids and 50 ppm chlorides.
- 11.4.5 The procedure to apply the chemical pre-treatment viz phosphoric acid wash followed by deionised water wash shall be in accordance with the recommendations of the manufacturer and shall be intended cleaning requirements of this specification and in case of conflict between this specification & manufacturer’s recommendations, manufacturer recommendation will be acceptable with prior approval of Consultant / Owner

11.5 Chromate Pre-treatment

- 11.5.1 The COATING CONTRACTOR shall ensure temperature of the substrate is maintained between 40 Deg.C and 80 Deg.C and chromate solution temperature does not exceed 60 Deg.C.
- 11.5.2 The diluted solution of chromate (10 percent shall be applied to the blast-cleaned steel surface by a suitable method such as rotating brushes that results in a completely wetted surface with a uniform film of chromate solution remaining on the surface. Any drainage concentration, drips, etc. especially in the weld area shall be removed by wiping or other suitable means.
- 11.5.3 The coating shall be smooth, even, free from runs, drips or excessive application and be of light brown colour, lightly adherent with no flaking of the coating. The chromate-coated steel must be thoroughly dried immediately after application and shall be achieved by boiling off any residual solution on the surface.
- 11.5.4 The COATING CONTRACTOR shall be fully responsible for adherence to local regulations and material safety data sheets, for using chromate solution.

12 COATING

The application of the coating shall be in accordance with the Manufacturer procedures approved by OWNER / CONSULTANT.

12.1 FBE Layer Coating

- 12.1.1 Minimum Thickness of FBE Coating shall be 180 micron & the maximum thickness shall not exceed the epoxy thickness specified by epoxy powder manufacturer.
- 12.1.2 The coating shall be applied by electrostatic spray with the pipe at earth potential the epoxy powder charged to high potential.
- 12.1.3 The pipe shall be uniformly preheated to a temperature of 235 Deg.C (450 Deg. F) or the FBE manufacturer” recommendation. The pipe metal temperature shall not exceed 275 Deg.C (575 Deg.F).

	<p align="center">SPECIFICATION FOR 3LPE COATING FOR LINE PIPE</p>	DOCUMENT NO.	REV
		11-0290-02-07-02-004	0
		SHEET 15 OF 29	

- 12.1.4 Pipe temperature shall be checked periodically by tempil sticks or a recording pyrometer. If a pyrometer is used, it shall be checked for error not less than every four hours against a calibrated temperature measuring instrument according to the procedural requirements of BS 5750.
- 12.1.5 Oxidation of the steel prior to coating in the form of “blueing” or other apparent oxide formation is not acceptable. If such oxidation occurs, the pipe shall be set aside and recleaned.
- 12.1.6 Prior to starting the fusion bonded epoxy powder application, the recovery systems shall be thoroughly cleaned to remove any unused powder.
- 12.1.7 The use of recycled powder shall not be permitted. Besides different brands of powder shall not be required.
- 12.1.8 During application, the bevelled ends and pipe bore shall be protected against mechanical damages and from contamination with coating material.

12.2. Adhesive Layer Coating

- 12.2.1 Minimum Thickness of adhesive layer shall be 200 micron & the maximum thickness shall not exceed the Adhesive thickness specified by Adhesive manufacturer.
- 12.2.2 The COATING CONTRACTOR shall ensure that the rollers push adhesive film into the base of weld to eliminate any air entrapment or voids immediately adjacent to the longitudinal weld. The adhesive layer shall be applied before gel time of the FBE has expired by using either the crosshead or lateral extrusion technique. Application of the adhesive shall not be permitted after the FBE has fully cured. The VENDOR shall establish to the satisfaction of OWNER / CONSULTANT representative that the adhesive is applied within the gel time window of the FBE and at the temperature recommended by the adhesive manufacturer. The COATING CONTRACTOR shall state the proposed minimum and maximum time interval between FBE and adhesive applications at the pipe temperature range and overlap.

12.3 Polyethylene Layer Coating

- 12.3.1 The high density polyethylene layer shall be applied on a thickness of 2.6 mm or balance after keeping min thickness of epoxy 180 microne & adhesive of 200 micron so that the min thickness on weld seam and body CS material 2.6 mm.
- 12.3.2 High-density polyethylene may be applied by either the crosshead or lateral extrusion technique. The polyethylene shall be applied over the adhesive within the time limits established during pre-production testing.
- 12.3.3 The coating shall be cooled to below 60 Deg.C before handling.

The coating cutback from the ends shall be 130 +10 mm. The ends of the coating shall be bevelled at 30 Deg to 45 Deg, or, as required by the filed joint manufacturer.
- 12.3.4 Immediately after the coating is fully cured, pipe identification marks shall be reapplied to the coated pipe using a method approved by OWNER / CONSULTANT representative. Additional identification shall be made in order to monitor the coating and test batches. All such markings shall be within 2 meters of the pipe end.

13 INSPECTION AND TESTING

13.1 General

In addition to the tests required on the material batches, the COATING CONTRACTOR shall perform the tests detailed below on finished coatings to demonstrate compliance with this specification. Details of all inspections and testing shall be fully documented in accordance with Section 14.0.

	<p align="center">SPECIFICATION FOR 3LPE COATING FOR LINE PIPE</p>	DOCUMENT NO.	REV
		11-0290-02-07-02-004	0
		SHEET 16 OF 29	

13.2 Coating Procedure Qualification Testing (PQT)

- 13.2.1 Prior to commencing full production, two pipe joints shall be coated with each pipe having a single layer FBE and eight with joints having a full coating system. In accordance with the coating procedure specifications, coating shall be witnessed by the VENDOR representative for Qualification Testing.
- 13.2.2 The two FBE coated pipes shall be subjected to complete set of tests as specified in Appendix 1.
- 13.2.3 The VENDOR shall select samples from 4 full system coated pipes. Samples shall be inspected and tested as per requirements detailed in Appendix 1.
- 13.2.4 Pipes selected for PQT testing shall pass all the criteria contained in Appendix 1 before production commences.

13.3 Production Testing

- 13.3.1 Production testing shall be performed at the frequency shown in Appendix 2.
- 13.3.2 The frequency of tests shown in Appendix 2 will be for normal production operations. This frequency of tests will also be required after a change in normal operations as a result of material change of quality acceptance.
- 13.3.3 One sample of coated pipe shall be sent to VENDOR for storage. Samples shall be taken from the same piece of pipe as the Cathodic disbondment test samples and should be one meter long and half the circumference of the pipe.

13.4 Visual Inspection

The following external surfaces of the coated pipe shall be carefully inspected:

- Adjacent to the longitudinal welds.
- Adjacent to the cut-back at each end of pipe
- Within the body of the pipe

The coating shall be of natural colour and gloss, smooth and uniform and shall be blemish free, with no dust or other particulate inclusions the coating shall not show any defects such as blisters, scratches, wrinkles, engravings, cuts, swellings, excess material thickness, disbonded zones, air inclusions, tears, voids, etc.

13.5 Coating Thickness

- 13.5.1 The thickness of the cooled polyethylene coating system shall be checked using an approved magnetic or electro-magnetic thickness gauge.
- 13.5.2 Measurements shall be made at 12 points uniformly spaced over the length and circumference of the pipe. At least 3 points shall be on longitudinal welds.
- 13.5.3 The minimum coating thickness on pipe surface and welds seam shall be 2.6 mm. However localised coating thickness of less than the permissible minimum thickness can be tolerated on the condition that it does not attain at total extent of more than 5 cm² per meter length of coated pipe, and actual coating thickness does not drop more than 10% below the permissible minimum coating thickness.
- 13.5.4 Any individual reading less than the requirements of Section 13.5.3 shall be cause for the coated pipe length to be rejected. Such pipe may be held for further inspection and possible acceptance by the OWNER / CONSULTANT representative.

	SPECIFICATION FOR 3LPE COATING FOR LINE PIPE	DOCUMENT NO.	REV
		11-0290-02-07-02-004	0
		SHEET 17 OF 29	

13.6 Holiday Detection

- 13.6.1 Each pipe shall be inspected for holidays over 100 percent of its coated surface using a high voltage DC detector after FBE and polyethylene layers application.
- 13.6.2 The detector shall be a type which maintains complete contact with the coating. It may be either constant or pulsed voltage type. If constant voltage type, holiday detection shall be carried on a dry coating. The operating voltage between electrode and pipe shall be checked at least twice per working shift and shall be maintained at 25 Kilovolts.
- 13.6.3 COATING CONTRACTOR shall demonstrate to be OWNER / CONSULTANT that setting of the detector is satisfactory for detecting pinholes. This setting will be checked once every two hours. The correct travel speed shall be determined by consistent detection of an artificial pinhole made in a good coating sample but shall not exceed 300mm/s.
- 13.6.4 The coating system shall be free from holidays.
All holidays and other defects shall be marked for subsequent repair and retesting. On retesting, no holidays shall be permitted in the final coating.
- 13.6.5 The number of holidays for each pipe length shall be recorded. Coating pipe having holidays in excess of 1 per 2 square meters shall be stripped and recoated at no additional cost to the VENDOR.
- 13.6.6 If excess occurrence of holidays on successive pipes, the COATING CONTRACTOR shall immediately stop the coating operation to determine the cause and remedy it.

13.7 Adhesion Test

- 13.7.1 The coating adhesion shall be determined in accordance with either of the methods described in DIN 30670. The test shall be performed at 20 ± 5 Deg.C and 50 ± 5 Deg.C. Tests shall be carried out on body and as well as on the longitudinal weld.
- 13.7.2 Minimum adhesion strength shall be 35 Newton's per centimetre of strip peeled at 20 ± 5 Deg.C, and 15 Newton's per centimetre width at 50 ± 5 Deg. C, in accordance with 4.2.3 and 5.3.3 of DIN 30670.
- 13.7.3 The failure mode shall be recorded. The failure should occur at the adhesive / polyethylene interface or adhesive / FBE interface or cohesively in the polyethylene layer. If failure should occur at the FBE / steel interface this will be considered a total failure of the system.
- 13.7.4 During adhesion testing, samples of coating shall be examined using 30X microscope for air entrapment on the body of the pipe or in the longitudinal welds.

13.8 Penetration Indentation Test

- 13.8.1 Three samples shall be cut from each of three pipes and tested for resistance to indentations in accordance with the method stated in DIN 30670. The test shall be performed at 23 ± 2 Deg.C and 70 ± 2 Deg.C.
- 13.8.2 Maximum penetration depth exhibited after testing shall not exceed 0.2 mm at a temperature of 23 ± 2 Deg.C or 0.3 mm at 70 ± 2 Deg.C.

13.9 Impact Test

- 13.9.1 A sample of coated pipe shall be impact tested in accordance with the procedures specified in DIN 30670. Tests shall be performed at temperatures of 23 ± 2 Deg.C and 65 ± 2 Deg.C.
- 13.9.2 When tested in accordance with DIN 30670, the coating shall withstand 30 impacts the distance between two parts of impact being at least 30 mm. Following rate test voltage of 25 KV shall be applied and it shall be checked whether breakdown occurs. The impact strength requirement is 7 joules (min.) of coating thickness.

 	SPECIFICATION FOR 3LPE COATING FOR LINE PIPE	DOCUMENT NO.	REV
		11-0290-02-07-02-004	0
		SHEET 18 OF 29	

13.10 Cathodic Disbondment Test

Cathodic disbondment testing shall be performed in accordance with ASTM G.42 for 28 days in a 3 percent sodium chloride electrolyte at 20 Deg. And 60 Deg. + 5 Deg. C temperature and a potential of – 1.5 volt, at qualification state.

During production, such a testing shall be performed under the same conditions for 48 hours.

Upon tests completion the maximum radius of disbondment shall be less than the following values:

Test Temperature	Qualification (28 days)	Production (48 hours)
20 + 5 Deg. C	5mm	3mm
60 + 5 Deg.C	15mm (Max.)	7mm (Max.)

Production test of 20 + 5 Deg. C may be exempted based on the review of initial results and OWNER / CONSULTANT approval.

Sample photographs showing disbonded area shall be included in test report.

13.11 Air Entrapment Assessment

13.11.1A sample of the applied coating shall be microscopically examined for the presence of foaming, voids and contamination.

13.11.2 No more than 20 percent of the observed area shall be taken with air entrapment (porosity or bubbles). Bubble size in the Polyethylene layer shall be limited to less than half the thickness of Polyethylene layer in height or circumference. Bubbles shall not link together to provide a moisture path to the adhesive / FBE layers.

13.11.3 Air entrapment or porosity shall be similarly rated for the adhesive and FBE layers of coating (See Appendix 3)

13.11.4 The strips of coating from the adhesion test should be studied to determine the level of air entrapment at this failure interface. This same area can be used to determine the air entrapment by cutting the coating at a 45° angle along the edge of the remaining coating on the pipe at the test area.

13.11.5 Coating immediately adjacent to each side of the longitudinal welds shall meet the parameters in 14.11.1 and 14.11.2 above for air entrapment.

13.12 Degree of Cure

A thermal analysis shall be carried out using a Differential Scanning Calorimeter (DSC).

Epoxy film samples shall be removed from the coated pipe using hammer and cold chisel. This produces curled coating flakes. Care shall be taken to remove samples of full film thickness but at the same time avoid the inclusion of steel debris and contamination with adhesive or polyethylene.

The sample shall be tested for cure using DSC procedure.

The glass transition temperature differential (Tg) shall be the test used to verify cure along with a visual examination to ensure no residual cure in the portion of the graph beyond the glass transition temperature.

The required cure characteristics are:

$$\Delta Tg = - 2^{\circ} C \text{ to } + 3^{\circ} C \quad (\Delta Tg = \Delta Tg \text{ final} - \Delta Tg \text{ initial})$$



SPECIFICATION FOR 3LPE COATING FOR LINE PIPE

DOCUMENT NO.

REV

11-0290-02-07-02-004

0

SHEET 19 OF 29

Only a 95% minimum cured coating shall be acceptable, based on calculation defined below:

$$\text{Present Cure} = \frac{\Delta H - \Delta H_{\text{residual}}}{\Delta H} \times 100$$

(ΔH – exothermic heat of reaction)

13.13 Destructive Tests

13.13.1 For coating destructive tests listed in Appendices 1 a sufficient length of production pipe shall be cold cut to provide the required number of samples for testing.

13.13.2 The coating on the cut end of the pipe length shall be cut back to comply with Section 13.3.4 of this specification.

13.14 Repairs

MANUFACTURER shall submit to PURCHASER, its methods and materials proposed to be used for executing a coating repair and shall receive approval from PURCHASER prior to use. In open storage the repair materials must be able to withstand a temperature of at least (+) 80°C without impairing its serviceability and properties. Manufacturer shall furnish manufacturer's test certificates for the repair materials clearly establishing the compliance of the repair material with the applicable coating requirements indicated in this specification.

All repair material will be of Class C.70 as specified in the relevant DIN Standard.

All pipe coating plant, shall have sound external with no holiday or porosity on 100% of the surface.

Defects, repairs and acceptability criteria shall be

- Pipes showing porosities or very small damage not picked up during holiday test and having a surface less than 0.5 cm² or linear damage (cut) of less than 3 mm shall be repaired by stick using material of same quality.
- Damages caused to coating by handling such as scratches, cuts, dents, gouges, not picked up during holiday test having a total reduced thickness on damaged portion not less than 2mm and an area not exceeding 20cm² shall be rebuilt as per approved method and without exposing to bare metal.
- Defects of size exceeding above mentioned area or holidays of width less than 300 mm shall be repaired as per approved method by exposing the bare metal surface.
- Defects exceeding the above and in number not exceeding 2 per pipe and their length not exceeding 500 mm shall be repaired as per approved method.
- Pipes with bigger damage shall be stripped and recoated.
- In case of coating defect close to coating cut back, MANUFACTURER shall remove the coating throughout the entire circumference of the pipe down to the steel surface and increase the coating cut back length. Now, if the coating cut back exceeds by 30mm than the specified cut back length, then the coating shall be repaired as per approved method thereby making up the coating cut back length as per specification.

In case the defect exceeds 70 mm from the original coating cut back length, the entire coating shall be removed and the pipe shall be recycled through the entire coating procedure.

Irrespective of type of repair, the maximum number of repair of coating shall be as follows:

- Holiday repair of size 100 cm² attributable to process of coating application shall be maximum one number per pipe.



SPECIFICATION FOR 3LPE COATING
FOR LINE PIPE

DOCUMENT NO.

REV

11-0290-02-07-02-004

0

SHEET 20 OF 29

Page 81 of 100

- In addition to the above, defects to be repaired as per approved method shall be maximum 2 (two) per pipe.

Defects exceeding the above limits shall cause pipe coating rejection, stripping and recoating. The above is exclusive of the repairs warranted due to testing as this specification.

All repairs carried out to coating for whatever reason shall be to the account of MANUFACTURER.

Cosmetic damages occurring in the polyethylene layer only need not be repaired by exposing up to steel surface, as deemed fit by the PURCHASER. In any case the MANUFACTURER shall establish his material, methods and procedure of repair that result in an acceptable quality of product by testing and shall receive approval from PURCHASER prior to use.

Testing of repairs shall be in the same form as testing coating. All repairs shall result in a coating thickness no less than the parent coating thickness. MANUFACTURER shall test repairs to coating as and when required by PURCHASER.

13.15 Test Failure

13.15.1 In the event that a production coated pipe fails to meet the acceptance criteria for a specified test or if the number of holidays detected is excessive, the pipe length shall be rejected unless approval is given by OWNER / CONSULTANT.

13.15.2 The pipe joint preceding and following a rejected joint in the same production run shall be similarly tested. If both are acceptable, the remainder of the pipe lengths in that batch shall be accepted. If either pipe joint fails the same test, the coating contractor shall provide a test schedule for OWNER / CONSULTANT approve, that will determine what pipes may be defective since the last passing test pipe.

14 DOCUMENTATION

14.1 The following documentation, written in the English Language shall be submitted to OWNER / CONSULTANT for review.

14.2 Prior to the start of Production Operations, Coating contractor shall submit the following documentation to the OWNER / CONSULTANT.

- Coating and Testing Procedures
- Detailed Description of Coating Equipment and Materials
- Pipe Handling Equipment Description and Procedures
- Pipe Stacking Arrangements
- Material Control Recording Procedure
- Inspection Quality Plan
- Repair Procedure
- Procedures for all PQT and Production Tests

14.3 Coating contractor shall submit to OWNER / CONSULTANT the following documentation prior to the return of coated pipe to Vendor.

- Mill Certificates for Line Pipe received.
- Manufacturer's Certificates for each batch of Coating Materials
- Certification / Calibration Certificates for all Testing and Coating Equipment
- Inspection and Test, Records, Results and other documentation of all material and Coating Tests.

14.4 All reports shall be signed by coating contractor to signify compliance with the requirements of this specification.

	<p align="center">SPECIFICATION FOR 3LPE COATING FOR LINE PIPE</p>	DOCUMENT NO.	REV
		11-0290-02-07-02-004	0
		SHEET 21 OF 29	

**APPENDIX 1
INSPECTION SUMMARY FOR PROCEDURE QUALIFICATION TEST
PE-COATING SYSTEM FOR ALL PIPE DIAMETER**

Property	Relevant Clauses	Acceptable Values	Number of Tests
Before Cleaning <ul style="list-style-type: none"> • Pipe Condition • Chlorides • Oil Contamination 	11.1 11.2.2 11.2.3	Conditions A & B of ISO 8501 (part 1) 5 μ g / cm ² No indications of oil contamination	10 30 (3x10 pipe) 10
After Cleaning <ul style="list-style-type: none"> • Cleanliness • Profile • Chloride • Dust and Oil 	11.3.4 11.3.5 11.2.2 11.3.6	Sa 2 – ½ 50 – 100 μ m 2 μ g / cm ² No indications of dust or oil contamination	10 10 30 (3x10 pipe) 10
Coating Thickness <ul style="list-style-type: none"> • FBE coated • FBE + Adhesive + PE 	12.1.1 13.5.3	Min 180 μ Min 2.6 mm on body Min 2.6 mm on weld seam	24 (12x 2 pipes) 48 (12 x 4 pipe)
Holidays <ul style="list-style-type: none"> • FBE • FBE + Adhesive + PE 	13.6 13.6	No Holidays No Holidays	2 5 Random
Visual aspect <ul style="list-style-type: none"> • FBE • FBE + Adhesive + PE 	13.4 13.4	Smooth with no surface defects Smooth with no surface defects	2 10
Adhesion <ul style="list-style-type: none"> • FBE • FBE + Adhesive + PE 	13.7.2	Refusal to peel or a cohesive failure 35N/cm at 20° C, 15N/cm at 50° C	2 10 (2 x 5 pipes)
Impact Resistance <ul style="list-style-type: none"> • FBE • FBE + Adhesive + PE 	13.9.1 13.9.2	7J (minimum) No electrical breakdown after 30 impacts	2 5 Random
Presentation (indentation testing) <ul style="list-style-type: none"> • FBE + Adhesive + PE 	- 13.8.2	-0.2 mm max. at 23 ± 2° C, 0.3 mm at 70 ± 2° C	10 (2 x 5 pipes)
Degree of Cure <ul style="list-style-type: none"> • FBE • FBE + Adhesive + PE 	13.12	- 2° C ≤ Δ Tg ≤ +3° C	2 3 Random
Flexibility Bend Test <ul style="list-style-type: none"> • FBE 	See Appendix 4	No cracking / disbondment pinholes	2
Hot Water Resistance <ul style="list-style-type: none"> • FBE 	See Appendix	No peel or cohesive break 2mm long No adhesive / brittle break 2mm long	1 Random



**SPECIFICATION FOR 3LPE COATING
FOR LINE PIPE**

DOCUMENT NO.

REV

11-0290-02-07-02-004

0

SHEET 22 OF 29

Page 83 of 100

Property	Relevant Clauses	Acceptable Values	Number of Tests
	5		
Cathodic Disbondment <ul style="list-style-type: none"> • FBE • FBE + Adhesive + PE 	13.10 -	Max. radius of disbondment 5mm at (20°C+5°C) (28days) & 3mm at (20°C+5°C) (48 hours) Max. radius of disbondment 15 mm at (60°C+5°C) (28days) & 7 mm at (60°C+5°C) (48 hours)	2 3 Random
Air Entrapment <ul style="list-style-type: none"> • FBE • FBE + Adhesive + PE 	See Appendix 3 13.11	No air entrapment in pipe or cut back or longitudinal welds.	2 10

Number of Tests can be increased at the sole discretion of OWNER / CONSULTANT

	SPECIFICATION FOR 3LPE COATING FOR LINE PIPE	DOCUMENT NO.	REV
		11-0290-02-07-02-004	0
		SHEET 23 OF 29	

**APPENDIX 2
INSPECTION SUMMARY FOR PRODUCTION TESTING ON FULL PE – COATING SYSTEM FOR
ALL PIPE DIAMETERS**

Property	Relevant Clauses	Acceptable Values	Number of Tests
Before Cleaning <ul style="list-style-type: none"> Pipe Condition Chlorides Oil 	11.1 11.2.2 11.2.3	Conditions A & B of ISO 8501 (part 1) 5 μ g./cm ² No indications of oil contamination	Each Pipe 1 per 100 pipe at 3 locations 1 per 100 pipe
After Cleaning <ul style="list-style-type: none"> Cleanliness Profile Chloride Dust Oil 	11.3.4 11.3.5 11.2.2 11.3.6 11.3.6	ISO – Sa 2 ½ 50 – 100 μ m 2 μ g / cm ² No indications of dust or oil contamination	Each Pipe Each Pipe 1 per 100 pipe 1 per 100 pipe 1 per 100 pipe
Chemical Pre-treatment <ul style="list-style-type: none"> Solution of Oakite 33 Chlorides Chromate solution chlorides Temperature 	11.4.4 11.5.1	<50 ppm <60°C	Once per shift Once per shift
Coating Thickness (minimum)	13.5.3	min 2.6 mm on body. min 2.6 mm on weld seam	Each pipe
Holidays	13.6	No holidays	Each pipe
Visual Inspection <ul style="list-style-type: none"> Coating Longitudinal Welds PE cut backs 	13.4 13.11 12.3.3	No surface defects No air entrapment 130 +10 mm width, level 45°	Each Pipe
Adhesion <ul style="list-style-type: none"> FBE FBE + Adhesive + PE 	13.7.2	Refusal to peel or a cohesive failure 35N/cm at 20° C, 15N/cm at 50° C	1 per 100 pipe
CATHODIC Disbondment <ul style="list-style-type: none"> FBE FBE + Adhesive + PE 	13.10	Max. radius of disbondment 5mm at (20°C+5°C) (28days) & 3mm at (20°C+5°C) (48 hours) Max. radius of disbondment 15 mm at (60°C+5°C) (28days) & 7 mm at (60°C+5°C) (48 hours)	First pipe, last pipe and at intervals of every 350 pipes

OWNER / CONSULTANT reserves the rights to increase inspection and testing frequency if warranted by the circumstances.

Note:-

- Profile test on each pipe - After achieving consistency, Frequency may be relaxed to 1/50 (max) at sole discretion of Owner / Consultant.
- Salt test after blasting & before blasting on each pipe - After achieving consistency, Frequency may be relaxed to 1/10 (max) at sole discretion of Owner / Consultant.

	SPECIFICATION FOR 3LPE COATING FOR LINE PIPE	DOCUMENT NO.	REV
		11-0290-02-07-02-004	0
		SHEET 24 OF 29	

APPENDIX 3

AIR ENTRAPMENT ASSESSMENT

1.0 Scope

To determine the amount of cross section and interface air entrapment (porosity or bubbles in the plant applied coating).

2.0 Equipment

2.1 Microscope – Hand Held 30 X.

2.2 Utility knife.

3.0 Test Specimen

Strips from Adhesive Tests, coating disbondment (CD) test samples and coated pipe may all be used to help determine the rating. Strips shall also be cut from longitudinal welds and examined for the presence of voids.

4.0 Procedure

4.1 Adhesion strip shall be viewed from the side and the failure interface.

4.2 Cathodic disbondment samples shall be viewed from the side before tests begins. Scraping with a sharp knife to remove cutting damage on the edge of the coating may be necessary to provide a smooth surface for viewing.

4.3 At the pipe adhesion test site use a utility knife to cut the edge of the coating to a 45° angle and view with a microscope.

4.4 Perform a similar test in the cut back area. This should be used for information to determine if further testing is needed.

5.0 Reporting and Grading

5.1 Report pipe joint number, date pipe was coated, coating batch number and date of test.

5.2 Report rating of cross-section and interface entrapment.

5.3 A rating of 1 or 2 is passing.

Rating will be on a scale of 1 to 5 as follows:

Rating

1.	Very Good	:	Passing
2.	Good	:	Passing
3.	Fair	:	Failing
4.	Poor	:	Failing
5.	Very Poor	:	Failing

JP KENNY



SPECIFICATION FOR 3LPE COATING
FOR LINE PIPE

DOCUMENT NO.

REV

11-0290-02-07-02-004

0

SHEET 25 OF 29

Page 86 of 100

Rating for each area of concern :

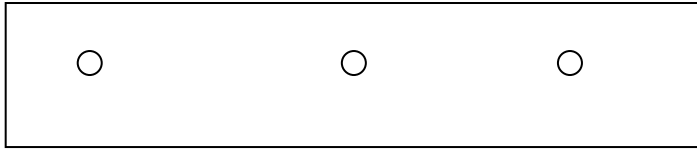

No.1 Rating – Passing
Less than 10% of are with bubbles

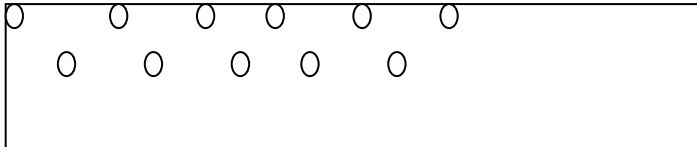

No.2 Rating – Passing
Less than 20%/ more than 10%

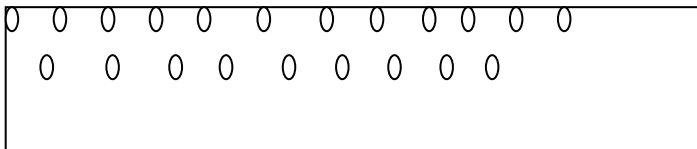

No.3 Rating – Failing
Less than 30%/ more than 20%

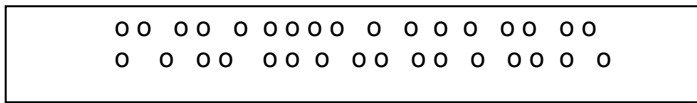

No. 4 Rating – Failing
Less than 40%/ more than 30%

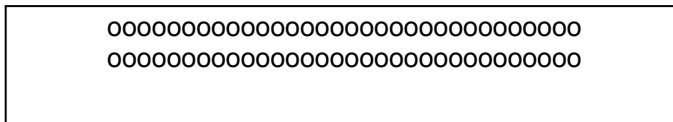

No. 5 Rating – Failing
Over 50% of area taken by air entrapment (bubbles)

By looking at the tope (outside) surfaces the same type rating system can be used.



SPECIFICATION FOR 3LPE COATING
FOR LINE PIPE

DOCUMENT NO.

REV

11-0290-02-07-02-004

0

SHEET 26 OF 29

APPENDIX 4

FLEXIBILITY TEST FOR FBE LAYER COATING PQT

1.0 Test Method

The flexibility of the coating shall be determined once on the first day of production of only FBE layer coated pipes (2 Nos) by the following method.

Coated samples (300mm x 50mm x thickness of pipe wall) taken from a FBE coated pipe joint shall be subject to a bend test at a temperature of 0°C and 20° C to induce a 2% and 3% strain respectively in the sample.

At each temperature the test shall be carried out twofold.

The deflection loading rate during bend testing shall be 25 ± 2mm /min.

The mandrel sizes shall be selected according to the following formula:

$$D = \frac{t(1-s)}{s}$$

D = mandrel diameter (mm)

t = specimen wall thickness (mm)

s = 0.02 at 0° C
0.03 at 20°C

2.0 Acceptance Criteria

The coating shall not exhibit any signs of cracking, disbondment or pinholes.

JP KENNY



SPECIFICATION FOR 3LPE COATING
FOR LINE PIPE

DOCUMENT NO.

REV

11-0290-02-07-02-004

0

SHEET 27 OF 29

Page 88 of 100

APPENDIX 5

HOT WATER RESISTANCE TEST FOR FBE LAYER COATING PQT

1.0 Test Method

Hot water resistance tests as detailed below shall be carried out on two pies coated with only FBE layer.

A coated sample of 200mm x 100 mm machined from a pipe ring of the coated pipe shall be immersed in tap water of 85° C for 5 hours.

The bare edges of the sample shall be coated to prevent ingress of moisture beneath the coating.

Directly after 5 hours exposure, the coated sample shall be removed from the water bath and allowed to cool to ambient temperature. Subsequently the coating adhesion shall be tested as follows:

Using a sharp and pointed knife, two incisions of approximately 15 mm in length shall be made through to the steel surface to form an 'X' with an angle of intersection of approximately 30 degrees. Commencing at the intersection, an attempt shall be made to lift the coating from the steel substrate using the blade of the knife.

2.0 Acceptance Criteria

Refusal of the coating to peel or a cohesive break less than 2 mm long entirely within the coating in the absence of excessive voids caused by foaming constitutes a pass.

Any adhesive break away from the intersection point or brittle break or flakes of more than 2 mm long constitute a failure.

Cohesive failure caused by voids in the coating leaving a honeycomb structure on the steel surface also constitutes a failed condition.

In addition, the coating shall not show any tendency towards disbonding or blistering. A slight discoloration of the coating is acceptable.

	SPECIFICATION FOR 3LPE COATING FOR LINE PIPE	DOCUMENT NO.	REV
		11-0290-02-07-02-004	0
		SHEET 28 OF 29	

APPENDIX 6

LIST OF APPROVED VENDORS (3 LPE)

Coating material Manufacturers acceptable to Company are as follows:

Epoxy : Dupont, 3M, BASF/Basepox, Jotun
 Adhesive : Dupont, BASF/Basell, Borealis, SK Corporation
 Polyethylene : S.K.Corporation, Novacorp, BASF.Basell, Borealis / Borouge,PB
 48A004 (GAIL PE Compound)

Repair Material	Heat Shrink Sleeves – Raychem	HTPL-80, PERP 80 PERP FILLER S1239 Epoxy or Canusa GTS-80, Mastic Filler, S/E/liquid epoxy and then should be followed by or equivalent material to be qualified by the material manufacturer and approved by Purchaser.
-----------------	-------------------------------	--

- Any combination of epoxy, adhesive and polyethylene shall be tested and certified by an internationally recognized agency.
- In case the MANUFACTURER proposed coating material other than above mentioned combination of epoxy, adhesive and polyethylene, coating procedure and qualification need to be carried out by an internationally recognized agency by the coating material Manufacturer.
- All materials to be used shall be supplied in sealed, damage free containers and shall be suitable marked with the following minimum information :
 - a. Name of the Manufacturer
 - b. Type of Material s
 - c. Batch Number
 - d. Place and Date of Manufacturer
 - e. Self Life / Expiry Date (if applicable)
 - f. Quantity

All materials noted to be without above identification shall be deemed suspect and shall be rejected by PURCHASER. Such materials shall not be used for coating and shall be removed from site and replaced by MANUFACTURER at his expense.

	<p align="center">SPECIFICATION FOR 3LPE COATING FOR LINE PIPE</p>	<p align="center">DOCUMENT NO.</p>	<p align="center">REV</p>
		<p align="center">11-0290-02-07-02-004</p>	<p align="center">0</p>
		<p align="center">SHEET 29 OF 29</p>	



GAIL GAS LIMITED
CITY GAS DISTRIBUTION PROJECT



QUALITY ASSURANCE PLAN / INSPECTION LEVELS	CLIENT JOB NO.	-
	TOTAL SHEETS	5

DOCUMENT NO	11	0290	02	07	10	001
--------------------	----	------	----	----	----	-----

--	--	--	--	--	--

0	4.11.09	ISSUED FOR CLIENT COMMENTS	MH	SB	SB
A	29.10.09	ISSUED FOR IDC	MH	SB	SB
REV	DATE	DESCRIPTION	PREP	CHK	APPR

QUALITY ASSURANCE PLAN / INSPECTION LEVELS



QUALITY ASSURANCE PLAN /
INSPECTION LEVELS

DOCUMENT NO.

REV

11-0290-02-07-10-001

0

SHEET 2 OF 5

QUALITY ASSURANCE & QUALITY CONTROL PLAN

The line pipe shall be duly quality controlled, inspected and certified for full compliance with the Codes and Standards and to specific requirements of the project.

Before leaving the mill all the line pipe shall be subject to certification as mentioned in specification / material requisition / purchase order.

Within two weeks time vendor shall establish and submit a comprehensive Quality Assurance Program and Quality Plan for CLIENT / CONSULTANT approval.

CLIENT / CONSULTANT reserve the right to nominate third party inspection agency for inspection and certification. Vendor in his quality assurance plan shall propose procedures to inform CLIENT / CONSULTANT on schedule of inspection / certification and shall as a minimum cover, the audits and certification of all vendors; their sub-vendors shall be a part of certification process.

Late notification to CLIENT / CONSULTANT, resulting absence of CLIENT / CONSULTANT representatives for certification shall lead to rejection of the event.

Vendor shall ensure the compliance as a minimum to the following :

- **QUALITY ASSURANCE REQUIREMENTS**

Full compliance with the approved Vendor's QA/QC plan.

- **INSPECTION AND TEST PLAN**

As per approved vendor drawing data requirements form.

- **DOCUMENTS**

As per vendor drawing data requirements form.

- **CALIBRATION RECORDS**

Only calibrated measuring and testing instrument shall be used by vendor, the records of calibration / recalibration shall be submitted to CLIENT / CONSULTANT.

- **QUALITY RECORDS**

Quality records shall be maintained by vendor. Inspection / test reports shall be furnished to CLIENT / CONSULTANT.

- **INSPECTION STATUS**

During the process of manufacture, inspection and test status shall be identified by marking, stamps, tags, cards, etc. and shall clearly indicate acceptance / rejection of inspection performed.

Identification of inspection and test shall be maintained and records to be submitted to CLIENT / CONSULTANT as and when required.

- **QUALITY RECORDS**

Quality records shall be maintained as per vendor's procedure. Inspection reports and records shall be furnished to CLIENT / CONSULTANT as and when required.

	QUALITY ASSURANCE PLAN / INSPECTION LEVELS	DOCUMENT NO.	REV
		11-0290-02-07-10-001	0
		SHEET 3 OF 5	

- **NON CONFORMITY REPORT**

On observing any deviation to specification CLIENT / CONSULTANT will issue a non conformity report (NCR). On receipt of NCR, vendor shall submit a detailed repair procedure for CLIENT / CONSULTANT approval and shall carry out all necessary repairs.

- **TRACEABILITY & IDENTIFICATION**

For identifying the products from applicable drawings / specification or other documents during all stages of production and delivery, vendor shall establish and maintain a written procedure. The procedure shall be made available to CLIENT / CONSULTANT.

All ambiguities related to the QA / QC requirements outlines above shall be brought to the attention of the CLIENT / CONSULTANT representatives.

	QUALITY ASSURANCE PLAN / INSPECTION LEVELS	DOCUMENT NO.	REV
		11-0290-02-07-10-001	0
		SHEET 4 OF 5	

INSPECTION LEVELS

1 LEVEL 0

No Quality Surveillance required.

2 LEVEL 1

Release for Shipment Surveillance. This level requires final surveillance inspection only to ensure that the complete equipment / material is :

- in compliance with the purchase order
- properly identified
- adequately prepared for shipment
- documentation requirements have been fulfilled

3 LEVEL 2

Limited Scope Surveillance. This level requires, in addition to surveillance activities outlined under level 1, a pre-fabrication visit to review the quality requirements established by purchase order plus witnessing of all verification and hold points outlined in the Quality Surveillance Plan.

4 LEVEL 3

Full Scope Surveillance. This level requires, in addition to surveillance activities outlined under level 2, random visits during the fabrication cycle with the purpose of monitoring and verifying the Supplier's compliance with his own Quality Control Program and purchase order specifications, on a spot check basis. The frequency of visits shall be based on the complexity of the equipment and the Supplier's performance.

5 LEVEL 4

Extreme Surveillance and Residency Surveillance. This level requires, in addition to surveillance activities outlined under level 3, daily visits or full residency as directed by the project. The Supplier's Quality Program execution shall be monitored on an ongoing basis and all specified tests shall be witnessed.

	QUALITY ASSURANCE PLAN / INSPECTION LEVELS	DOCUMENT NO.	REV
		11-0290-02-07-10-001	0
		SHEET 5 OF 5	

FORM - A

CHECK LIST – TECHNICAL

REQUISITION FOR :	EW / SEAMLESS CARBON STEEL COATED LINE PIPES
PROJECT :	CITY GAS DISTRIBUTION PROJECT

Bidder confirms following, as a minimum, have been enclosed in the offer:

Sl. No.	Requirements	Complied by Bidder
1.0	Total compliance to technical requirements of the Material Requisition, as per Compliance Statement (Form-C), enclosed.	Yes/No
2.0	Bidder has clearly identified the quoted items covered in Material Requisition including location of pipe mill(s) where the quoted items are proposed to be manufacture.	Yes/No
3.0	Type of Line pipe (EW /SEAMLESS) quoted has been clearly indicated for each quoted item, as applicable.	Yes/No
4.0	Bidder meets Bidder's qualification criteria (BQC) and documentary evidence in support of BQC is enclosed in the offer as per following, as a minimum:	Yes/No
	a) Name & Location of Proposed Pipe Mill	Yes/No
	b) Valid API 5L certificate and copy of license to use API monogram on line pipes of PSL 2 quality as per API spec 5L	Yes/No
	c) Proposed Pipe Mills' past track record for supply of line pipes of same or higher in terms of diameter, wall thickness and grade in the last seven years as per (Form-B)	Yes/No
	d) A certificate from reputed international inspection agency (i.e.CEIL/ Lloyds/ BV/ DNV/ TUV/ ABS/ Moody) is enclosed in 'Format-A' for proposed pipe mill, certifying that the proposed mill has the capability to produce linepipes complying technical requirements specified in the bid document.	Yes/No
	e) Documentary evidence in support of BQC (i.e. copies of W.O./P.O (without price), Inspection release notes,completion certificate etc.)	Yes/No

To be filled, signed and stamped by Bidder.

Bidder's seal

Signature of Bidder

FORM – B

PROPOSED PIPE MILLS' PAST TRACK RECORD FOR SUPPLY OF LINE PIPES OF SAME OR HIGHER IN TERMS OF DIAMETER, WALL THICKNESS AND GRADE IN THE LAST SEVEN YEARS

REQUISITION FOR :	EW / SEAMLESS CARBON STEEL COATED LINE PIPES
PROJECT :	CITY GAS DISTRIBUTION PROJECT

S.No.	Project	Client(Name & Address)	Diameter	Wall Thickness	Material & Grade	Service	Year of Supply

To be filled, signed and stamped by Bidder.

Bidder's Seal

Signature of Bidder

FORM - C

COMPLIANCE STATEMENT

REQUISITION FOR :	EW / SEAMLESS CARBON STEEL COATED LINE PIPES
PROJECT :	CITY GAS DISTRIBUTION PROJECT

The vendor shall confirm below the Sections of the Requisition / Specification that he has complied with / accepted. Columns 2, 3, must be answered and initialled.

Specification No. Section No.	11-0290-02-07-02-003	*Conforms Yes / No	Noted Yes / No
TECHNICAL SPECIFICATION FOR ERW LINEPIPE			
1			
2			
3			
5			
6			
7			
9			
10			
11			
12			
14			
15			
TECHNICAL SPECIFICATION FOR SEAMLESS LINEPIPE			
1			
2			
3			
4			
5			
6			
7			
8			
9			
10			

11		
12		
13		
14		
15		

Notes: * Acceptance (i.e. Yes) implies total compliance to the Specifications.
@ Provide additional explanatory sheets if required.

No Deviation Tender

FORM - C

COMPLIANCE STATEMENT

REQUISITION FOR :	EW / SEAMLESS CARBON STEEL COATED LINE PIPES
PROJECT :	CITY GAS DISTRIBUTION PROJECT

The vendor shall confirm below the Sections of the Requisition / Specification that he has complied with / accepted. Columns 2, 3, must be answered and initialled.

Specification No. Section No.	11-0290-02-07-02-004	*Conforms Yes / No	Noted Yes / No
1.0			
2.0			
3.0			
4.0			
5.0			
6.0			
7.0			
8.0			
9.0			
10.0			
11.0			
12.0			
13.0			
14.0			
APPENDIX 1			
APPENDIX 2			
APPENDIX 3			
APPENDIX 4			
APPENDIX 5			
APPENDIX 6			

Notes: * Acceptance (i.e. Yes) implies total compliance to the Specifications.
 @ Provide additional explanatory sheets if required.

No Deviation Tender