



**GAIL (India) Limited**  
(A Govt. of India Undertaking)

**PIPELINE FROM HANUMAN JUNCTION TO VCL**

**BID DOCUMENT  
FOR  
PIPELINE LAYING & TERMINAL WORKS**

**VOLUME – II OF II (CATHODIC PROTECTION)**

**(BID DOCUMENT NO: 110330G/WGI/GAIL/01-R0)**

**OPEN DOMESTIC COMPETITIVE BIDDING**



**DELIVERS. EVOLVES.**

WHOLE LIFE SOLUTIONS FOR PIPELINE AND SUBSEA SYSTEMS

**ISSUED BY**



**TABLE OF CONTENT**

<b>S.No.</b>	<b>DOCUMENT TITLE</b>	<b>DOCUMENT NUMBER</b>	<b>No. of Pages</b>
1.0	DESIGN BASIS FOR CATHODIC PROTECTION	11-0330G01-02-10-04-101	07
2.0	TECHNICAL SPECIFICATION FOR TCP & PCP	11-0330G01-02-10-02-101	49
3.0	STANDARD CATHODIC PROTECTION DRAWINGS	1-10-001 TO 1-10-011	11





**GAIL (India) Limited**  
**HANUMAN JUNCTION TO VCL PIPELINE**



**DESIGN BASIS  
FOR  
CATHODIC PROTECTION**

**CLIENT JOB NO.** 110330

**TOTAL SHEETS** 07

**DOCUMENT NO**

11

0330G01

02

10

04

101

REV	DATE	DESCRIPTION	PREP	CHK	APPR
0	05/07/11	ISSUED FOR TENDER	AT	SNP	SB
A	01/07/11	ISSUED FOR I.D.C.	AT	SNP	SB

## 1.0 INTRODUCTION

M/s Gail India Limited intends to lay a pipeline from Hanuman Junction (Chainage 154KM) on Tatipaka-Lanco pipeline to VCL where check metering station is proposed to be located.

The total 45 kms of Pipeline shall be divided in two spreads (Ch 0.00 to Ch 22.00 in one spread and Ch 22.01 to Ch 45.00) & work to start simultaneously for both the spreads.

This Document provides the Design Basis for Cathodic Protection system [TCP] & [PCP] for the proposed gas Pipeline.

## 2.0 PIPELINE DETAILS:

2.1 The Pipeline details are:

- Line Size : 8" NB
- Line Length : 45 Km approx.
- Class : 600#
- Design Pressure : 72 Kg/Sq. Cm
- Operating pressure : 42.5 Kg/Sq. Cm at Tatipaka  
31.0 Kg/Sq. Cm at Hanuman junction
- Material of Pipe : API 5L X-56
- Coating Material : 3 LPE
- Wall Thickness : 6.4mm

3.0. Cathodic Protection System :

It is envisaged to provide catholic protection to the externally coated MS pipeline from ravages of soil side corrosion in following two steps:

3.1 Temporary Cathodic Protection [TCP] :

Using sacrificial [Mg or Zn] anodes pre-packed in back-fill for the design life of one (1) year, or the construction period, whichever is later.

3.2 Permanent Cathodic Protection System [P-C-P]:

Impressed current Cathodic Protection [ICCP] System Using Mixed Metal Oxide [MMO] anodes [LIDA single] in specified carbonaceous back-fill, for a design life of Forty (40) years and Powered by AC Input and DC Output Transformer Rectifiers or DC input and DC output CPPSM..

4.0 Codes & Standards & Recommended Practices :

4.1 Latest edition of:

Bureau Of Indian Standards [BIS]



DESIGN BASIS  
FOR  
CATHODIC PROTECTION

Document No.

11-0330G01-02-10-04-101

SHEET 2 of 7

Rev

0

National Association Of Corrosion Engineers [NACE]  
 British Standard [BS]  
 American Petroleum Institute [API]  
 Indian Electricity Rules [IER]  
 Indian Petroleum Rules [IPR] Safe Practices  
 Institute Of Electronics & Electrical Engineers [IEEE]  
 Indian Electricity Act [IEA]  
 National Fire Protection Agency [NFPA]  
 Chief Controller of Explosives [CCE] Regulations  
 Oil Industry Safety Directorate [OISD] Norms

4.2 In case of conflict the most stringent will apply. However, the order of priority will be :

Statutory Rules  
 Project Specifications  
 Codes & Recommended Practices

5.0. Site Conditions:

The equipment to be used for this project shall conform to following site Requirements / Conditions:

- ❖ Temperature - Maximum 65<sup>0</sup>C & Minimum -29<sup>0</sup>C
- ❖ Design Temperature - 65<sup>0</sup>C
- ❖ Relative Humidity - 100%
- ❖ Altitude Above Sea Level - Less ≤ 1,000M
- ❖ Atmospheric Pollution - Tropicalized to Withstand the site Conditions, dust, vapor etc.
- ❖ Hazardous Area Classification - Zone2, Gas Gr.IIA & IIB  
Temperature Class T3
- ❖ Control Room / Battery, TRU room - Safe Area

6.0 Hazardous Area Classification & Equipment Classification:  
 All Electrical equipment installed in Hazardous area will be in accordance with API 500, BIS 5571, 5572, & OISD 149.

6.1 Flame Proof equipment shall be CMRI or Owner Approved Agency Certified.

7.0 Design Life & Basis:

7.1 Design Life of [TCP] system to be one (1) years or till commissioning of [P-C-P] whichever is latter.

7.2 Design Life of [PCP] system to be forty (40) Years. Soil/Water Chemical & Microbial Analysis.



**DESIGN BASIS  
 FOR  
 CATHODIC PROTECTION**

Document No.	Rev
11-0330G01-02-10-04-101	0
<b>SHEET 3 of 7</b>	

7.0 Electrical Equipments:

Following equipments are envisaged for this project:

Equipments required in both [TCP] & [PCP] are to be designed and installed during [TCP] installation.

S.No.	[TCP]	[PCP]	Remarks
1	Sacrificial [Mg or Zn] Anode pre-packed in Back-fill	MMO [LIDA Single] Anodes in Carbonaceous back-fill & Cable	
2	Test Lead Points[TLP] with shunt & resistors	Junction Boxes [JB],[AJB]	IP55 Enclosure
3	Corrosion Coupons with Magnetic Reed switch & Copper Sulphate Reference electrode	AC Input & DC Output Transformer Rectifier Unit [TRU]	IP55 Enclosure
4	Surge Diverters at Insulation Mono blocks		
5	Permanent Copper Copper Sulphate Reference Electrode	Earthing for TRU And Distribution Board	
6	Pipe to Cable connection –Pin Brazing, Epoxy Encapsulated		
7	Solid State DC De-coupling device		
8	Grounding cell for H.T. overhead Lines		
9	Zn or Mg Anode Grounding for MOV/SV	ER Probes for corrosion monitoring	
10		[P-S-P] Converter	To Be Installed away from CP Stations, in Instrumentation Panel
11	Coated Casing Protection with Sacrificial anodes		Separate from [ICCP] more than 10M
12	Carrier Inside Casing Protection with Ribbon Anodes		Additional Carrier Protection inside casing more than 20M

9.0 Cathodic Protection Criteria :

- 1) [P-S-P] Minimum (-) 0.95 V “On” Maximum (-) 1.5 V”On” w.r.t.CSE
- 2) Corrosion Coupons [P-S-P] “Off” Minimum (-).95 V and Maximum (-)1.18v “Off” Vs SCE
- 3) In exceptional circumstances a swing of 100mV in Polarization potential may also be acceptable with Sole discretion of Owner.

10.0 Protective Current Density

For the 3 layer polyethylene [3XLPE] coated pipeline following protective current density to be used:

	Marshy Soil	Normal Soil
For TCP & PCP	- 35 $\mu\text{A}/\text{M}^2$	20 $\mu\text{A}/\text{M}^2$



11.0 PERMANENT REFERENCE ELECTRODE

11.1 In Soil – copper copper sulphate electrode will be provided.

11.2 Three (3) numbers to be installed, at each CP Station.

11.3 One (1) number to be installed ,midway between two CP Stations, if one (1) C.P station install one CSE (PSM) at other end.

11.4 To be installed at extremely vulnerable locations.

11.5 In water –silver silver chloride [Ag-AgCl] Reference to be installed / Used.

12.0 Insulation mono block joints (i/j)

I/J Numbers will be provided between under ground pipe and above ground pipe to sectionalize electrically the protected and unprotected pipe.

13.0 SPARK GAP ARRESTOR

13.1 To be installed at every insulation mono block joint for grounding surges, if any.

14.0 POLARIZATION CELLS – SOLID STATE TYPE

14.1 To mitigate A.C. Interference, solid state type Polarization Cells to be installed at as required for A.C. interference mitigation in the section where interference is detected.

15.0 TR UNITS

15.1 TR unit will receive power from the AC feeder or Battery Back-up (available from UPS).

16.0 OPERATING REQUIREMENTS

16.1 UPS Power supply:

Voltage	-	230V ± 1%
Frequency	-	50 Hz ± 5%
Phase & Wire	-	1P, N & 2W
Fault level	-	10KA for 1 sec
Neutral Earthing	-	Solidly earthed

Solar Power supply:

24V DC ± 1%
-
2W
10KA for 1 sec

16.2 Transformer Rectifier unit:



- 16.3 Output
- Voltage - 25 V ± 10% DC
- Current - 25A ± 10% DC
- 16.4 Alternative Input DC From UPS / Solar Power System [when AC Trips]
- 16.5 Any other control supply if required, will be arranged by the contractor as per equipment requirement.
- 16.6 TR unit / CPPSM will be capable of giving online data to SCADA system with-in built current interrupter and potential free contacts.
- 16.7 TR unit / CPPSM will be weather proof enclosure ,with hinged lockable shutter and degree of protection IP-55 .
- 17 CASING PROTECTION
- 17.1 All the casing Annulus shall be filled with Bentonite + sand mixture or Paraffin wax or Petroleum jelly to control ingress of moisture in the annulus . This will not apply to casing under Railways.
- 17.2 Only For casing longer than 20 M, Carrier inside Casing shall be provided Additional cathodic protection with Ribbon anodes.
- 18 CABLE CONNECTION TO PIPE
- 18.1 Cable will be connected on pipe by carrying out pin brazing with low contact resistance. At every location at least two cable from pipe to be pin brazed & brought to [TLP]
- 19 SPECIAL REQUIREMENT
- 19.1 Permanent Anode Bed will be deep well type(only if ROU for locating shallow anodebed 100 m away is not available ) or alternatively the land 100 m away from ROW.Land required for shallow/deep well anodebed will be acquired by successful bidder in the name of M/s GAIL India Ltd.. The area of anodebed will be fenced with single gate.The area required will be sufficient for C P installation & checking the facilities at each anodebed location and will not be less than 8 m x 8m in size.
- CP contractor will also arrange permission from owner of the land for use by GAIL,for laying anode head cable from Anodebed to TRU at CP station and right to access to this,as and when required,for O&M purposes.
- 19.2 PSP converter and reference CSE will be provided at all location wherever SCADA , RTU available .



20.0 Computerized Test Station Unit [CTSU] :

Computerized Test Station Unit [CTSU] (alongwith Reader Unit) -One (1) Numbers to be supplied and CSE Permanent type to be installed at all CTSU.

21.0 Corrosion Coupons :

Made from pipe material to be installed at one (1) locations along ROW.Magntic reed switch to be installed in circuit for "Off" Potential measurements.

22.0 Test Station [TLP] & Junction Boxes [JB]

Test station to be installed approx. every 1 Km. maximum all along the pipeline ROW.These [TLP] to be provided with Shunt & Resistors for individual Anode current output control.All [TLP] to have IP 55 Protection and are to be installed at accessible locations along ROW to facilitate CP System adequacy Monitoring.[TLP] to be installed at Rail,River,Canal,Road,Overhead High Tension Transmission Power lines,Pipeline and other line/cable crossings as well as Insulation Joints.Accordingly [TLP] to be named Type,A,B,C,D,E,F etc.Every 10 Kms. Of ROW Line current Measurement [TLP] to be installed.

CTSU to be installed in [TLP],wherever [P-S-P] convertor is to be installed and no C P Station is nearby,it will be installed inside of Instrument panel. [AJB] & [CJB] having IP 55 Protection to be installed at each [ICCP] CP Station.

23.0 Post Commissioning Surveys :

To be conducted after one month of CP Commissioning. Pearson Survey,Coating Conductance survey,Close Interval Computerized Potential Logging [CIPL] ["On" & "Off"] and AC,DC Interference survey & Mitigation.

Any defects or in-adequacy detected during post commissioning surveys should be rectified by CP contractor to handover Interference free adequately protected pipeline to M/s GAIL.

24.0 Periodic Monitoring Of Installed C P System :

The Installed C P System will be periodically Monitored for Protection Adequacy & Methodology of Monitoring & Formats & frequency for Monitored data Recording to be prepared by C P Contractor.

	<b>DESIGN BASIS FOR CATHODIC PROTECTION</b>	<b>Document No.</b>	<b>Rev</b>
		11-0330G01-02-10-04-101	0
		<b>SHEET 7 of 7</b>	



**GAIL (India) Limited**  
**HANUMAN JUNCTION TO VCL PIPELINE**



**TECHNICAL SPECIFICATION  
FOR  
TCP & PCP**

**CLIENT JOB NO.** 110330

**TOTAL SHEETS** 49

**DOCUMENT NO**

11

0330G01

02

10

02

101

0

05/07/11

ISSUED FOR TENDER

AT

SNP

SB

A

01/07/11

ISSUED FOR I.D.C.

AT

SNP

SB

**REV**

**DATE**

**DESCRIPTION**

**PREP**

**CHK**

**APPR**

## TABLE OF CONTENTS

SI.No.	DESCRIPTION
1.	INTRODUCTION
2	CORROSION SURVEY DATA
3	ADDITIONAL DATA TO BE COLLECTED
4	CATHODIC PROTECTION DESIGN PARAMETERS
5	CATHODIC PROTECTION DESIGN CRITERIA.
6	SYSTEM DETAILS
7	ANODE GROUND BEDS
8	ANODES
9	PETROLEUM COKE BREEZE
10	AC OPERATED AUTO/MANUAL TRANSFORMER RECTIFIER UNIT [
11	REFERENCE ELECTRODE [CuCuSO <sub>4</sub> ] PERMANENT TYPE
12	TEST STATIONS [TLP]
13	SURGE DIVERTER, GROUNDING CELL AND POLARISATION CELL
14	CP AT CASSED CROSSING
15	PAINTING
17	CABLES
18	CIVIL WORKS
19	TESTING AND INSPECTION AT WORKS
20	PACKING AND TRANSPORTATION
21	SYSTEM TESTING, COMMISSIONING AND INTERFERENCE MITIGATION
22	SYSTEM MONITORING
23	DRAWINGS AND DOCUMENTS
24	INSTRUMENTS, TOOLS AND SPARES
25	INFORMATION REQUIRED WITH THE BID
26	APPROVED MAKE OF EQUIPMENT / COMPONENTS FOR CP SYSTEM
27.	ANNEXURES



**TECHNICAL SPECIFICATION  
FOR TCP & PCP**

**Document No.**

11-0330G01-02-10-02-101

SHEET 2 of 49

**Rev**

0

## 1. INTRODUCTION

M/s Gail India Limited intends to lay a pipeline from Hanuman Junction (Chainage 154KM) on Tatipaka-Lanco pipeline to VCL where check metering station is proposed to be located.

The total 45 kms of Pipeline shall be divided in two spreads (Ch 0.00 to Ch 22.00 in one spread and Ch 22.01 to Ch 45.00) & work to start simultaneously for both the spreads.

It is envisaged to protect the external surface of by Cathodic Protection [CP] System: Temporary CP System [TCP] using sacrificial [Mg or Zn] Anodes for an initial One (1) year construction period, followed by Impressed Current Cathodic Protection [ICCP] system [PCP] using [MMO] Anodes & external Power source [AC Input DC Output TRU at Receipt Terminal or 24V DC input and DC output CPPSM at SV1] for a Design Life of forty (40) years.

- 1.1 This specification defines the requirements of site surveys for design data generation, CP design, detailed engineering, supply of materials, quality assurance (QA) and quality control (QC), installation, testing and pre-commissioning, commissioning of temporary Cathodic protection system [TCP] and permanent Cathodic protection system [PCP] for protecting throughout the design life [1+40 years] the external surface of cross-country 3LPE coated underground pipeline including detection of A.C & D.C. interference / interaction with neighbouring structures all along the pipeline ROW, as well as Installation of requisite Mitigative measures for the [A.C/D.C.] interaction / Interference mitigation. Also included in the scope of work are post-commissioning surveys such as CIPL ("On" & "Off") computerized logging along ROW and Coating conductance measurements along the pipeline ROW, Pearson detection followed by DCVG [for defect classification] at defect locations evinced .
- 1.2 This specification defines the basic guidelines to develop a suitable temporary Cathodic protection [TCP] system followed by permanent [PCP] Cathodic protection [ICCP] system for the underground pipeline [external surface coated with 3LPE required to be protected from ravages of soil side corrosion. All data required in this regard including site surveys to verify the design data shall be taken into consideration by the CP contractor to develop an acceptable state of the art [TCP],[PCP] design and for proper engineering & detailing of the [TCP],[PCP] systems.
- 1.3. Compliance with these specifications and/or approval of any of the contractor's documents shall in no case relieve the contractor of his contractual obligations of providing adequate Cathodic protection [TCP],[PCP] system suitable for desired number of service [1+40] years free of interference.
- 1.4. Activities of permanent [PCP] system which are common to temporary [TCP] system shall be completed as part of temporary [TCP] system. The facilities installed for [TCP], if useful & required in [PCP] system (such as TLP, permanent Reference CSE electrodes, Cable to Pipe connection, Corrosion coupons, etc.) shall be utilized for [PCP] also & hence are to be designed & installed as per [PCP] requirements.



### TECHNICAL SPECIFICATION FOR TCP & PCP

Document No.

11-0330G01-02-10-02-101

SHEET 3 of 49

Rev

0

- 1.5 All works to be performed and supplies to be effected as part of this contract shall require specific approval of owner or his authorised representative. Major activities requiring approval shall include, but not be limited to, the following:
- a) Methodology of **Corrosion survey site data generation** and interpretation report and design basis for [TCP],[PCP] system.
  - b) **CP System design package** including formulae used, design calculations, BOQ, Technical Specifications, Installation work procedure, and Post Commissioning Monitoring Methodology, Data Recording Formats etc.
  - c) Quality Assurance Control [QA/QC] methodology.
  - d) Procedure for field testing and commissioning.
  - e) Procedures for A.C and D.C. interference testing and mitigation.
  - f) Procedure for Post Commissioning surveys.
  - g) As-Built Documentation.
  - h) O&M Manual.

1.6. The Intending Bidder shall be deemed to have visited the Site pipeline ROW and Familiarized before Submitting the tender. **Non familiarity with site conditions will not be accepted as a reason either for extra claims or for not carrying out the work in total conformity with these tender specifications.**

1.7. The CP contractor will have to accordingly mobilize work and deploy adequate skilled & trained manpower conversant with work procedure, adequate number of tools, tackles, testing and Construction Equipments requisite for smooth work progress so that CP work could also be completed within Schedule specified for the project. The CP contractor shall work in close coordination with the main pipeline contractor.

1.8 **TECHNICAL DATA - MAINLINE**

The Pipeline details are:

- Line Size : 8" NB
- Line Length : 45 Km approx.
- Class : 600#
- Design Pressure : 72 Kg/Sq. Cm
- Operating pressure : 42.5 Kg/Sq. Cm at Tatipaka  
31.0 Kg/Sq. Cm at Hanuman junction
- Material of Pipe : API 5L X-56
- Coating Material : 3 LPE
- Wall Thickness : 6.4mm



**TECHNICAL SPECIFICATION  
FOR TCP & PCP**

<b>Document No.</b>	<b>Rev</b>
11-0330G01-02-10-02-101	0
<b>SHEET 4 of 49</b>	

1.8.2. The system design, performance and materials to be supplied shall unless otherwise specified, conform to the requirements of latest relevant applicable standards:

- ❖ BIS Standards
- ❖ BS Standards and codes of practice
- ❖ ANSI Standards
- ❖ NFPA Standards
- ❖ NACE Standards and Recommended practices
- ❖ IEC Standards
- ❖ DNV Standards
- ❖ IEEE Standards
- ❖ DIN Standards
- ❖ ASTM Standards
- ❖ OISD Standards & CCE Norms
- ❖ API Model code of safe practices
- ❖ GAIL Safety Standards
- ❖ All statutory, state, local requirements and norms  
[All latest available editions only.]

In case of conflicting requirements amongst any of the above standards, the publication having most stringent requirement shall be governing. However, the priority in such instance shall be as follows:

- Statutory Regulations and norms
- This Specification
- Codes & Standards, Recommended practices

## 2. CORROSION SURVEY DATA

**Corrosion Survey Data** collected already from site [pipeline ROW & Anodebed locations] viz: **Soil Resistivity, Soil Chemical analysis for chemical and microbial loading** is enclosed:

- i. Soil Chemical Analysis - As per Annexure-1.
- ii. Soil Resistivity - As per Annexure-2.

However, verification of its veracity and Adequacy shall be the entire responsibility of the CP contractor.

**In addition the CP contractor shall have to generate/collect additional Data** from site such as:

The CP contractor shall carry out a site survey along pipeline ROW and at proposed Anode bed locations, in order to verify design data, prior to the final design of the [TCP], [PCP] system. The site survey shall generally include the following:

	<b>TECHNICAL SPECIFICATION FOR TCP &amp; PCP</b>	<b>Document No.</b>	<b>Rev</b>
		11-0330G01-02-10-02-101	0
		<b>SHEET 5 of 49</b>	

**General information [Topographic] of terrain along which the pipeline is to be routed.**

Measurement of soil resistivity [  $\rho$  ] along ROW and at Anode bed plots. Each selected Anode bed plot shall be sub-divided into sub-plots. Size of the sub-plots shall depend upon investigation of soil resistivity upto requisite depth. Each of these sub-plots shall be investigated individually. Sufficient observations at each of these plots shall be recoded as recommended hereunder:

- 1) Soil Resistivity at every 2 Kms along ROW to be carried out at 1,2,3 M depths. Wherever, abrupt changes are observed additional readings to be recorded in between.
- 2) Soil Resistivity at Anode-bed plots to be recorded at 1,3,5M for shallow Anode beds and 1,3,5,7,10,15,20,25,30,35,40... M for Deep well Anode beds.

Chemical Analysis of Soil / Water samples collected from two depths [1.0M] and [2.0M] of pipeline ROW at every 5 Kms. and at each intersection of a grid from sub-plots for each anode beds location. The air dried soil samples to be quartered, coned and aqueous extract prepared for chemical and microbial analysis of following:

Cations [ppm]	Anions [ppm]	others	Microbes
Sodium	sulphate	TDS	Sulphate reducing bacteria
Potassium	sulphide	Moisture (%)	[SRB] colonies
Calcium	chloride	Redox Potential	
Magnesium	carbonate	p <sub>H</sub>	
	Bi-carbonate		
	Nitrate		
	Nitrite		
	Phosphate		

This data to be used for calculating soil/water corrossivity based on which and clause 5.1 of this specification, the protective current density and Anode material shall be selected/decided.

Chemical Analysis of Soil / Water samples collected from two depths [1.0M] and [2.0M] of pipeline ROW and at each intersection of a grid from sub-plots for each anode beds location. The air dried soil samples to be quartered, coned and aqueous extract prepared for chemical and microbial analysis of following:

Cations [ppm]	Anions [ppm]	others	Microbes
Sodium	sulphate	TDS	Sulphate reducing bacteria
Potassium	sulphide	Moisture (%)	[SRB] colonies
Calcium	chloride	Redox Potential	
Magnesium	carbonate	p <sub>H</sub>	
	Bi-carbonate		
	Nitrate		
	Nitrite		
	phosphate		

This data to be used for calculating soil/water corrosivity based on which and clause 5.1 of this specification, the protective current density and Anode material shall be selected/decided.

#### Stray Current Survey:

Survey for investigating possible sources of stray currents along ROW so that requisite Mitigative measures are included in the CP design. The CP contractor carrying out CP Interference survey due to DC current will have to get necessary permissions from other utilities such as underground pipelines of ONGC, IOCL, HPCL, BPCL, GAIL, etc., over ground water pipeline running parallel on concrete pedestal, and DC rail traction etc. so that composite studies for interference detection are done and recommended Mitigative measures are installed. At the time of handing over the interference free system to owners (GAIL), the contractor will hand over these permissions of other utility owners, for further needful by GAIL.

Where a site survey is not possible the C P contractor shall ensure that requisite data is available for him to fulfil requirements of the work order.

Survey for knowing the location of **existing Cathodic Protection system** to maintain appropriate clearance between the existing and upcoming C P Systems. CP contractor, prior to CP Design for, shall carry out extensive site surveys and data collection, from pipeline ROW and proposed Anode bed locations. Likely interfering elements along ROW, survey for sources of stray currents likely to cause interference, and shall base the CP System Design on this Data collected from site.



Ground Water Table Data to be collected either from GSI [Geological Survey of India] by CP contractor or measured at site to ensure Anode bed location in appropriate perennially moist environment round the year throughout service life.

In addition contractor shall have to collect/ generate additional Data as required for completeness of the C P job for GAIL as follows:

**3.0 ADDITIONAL DATA TO BE COLLECTED**

The following data shall be collected to generate design data for evaluation of interaction/ interference possibilities due to presence of other services in ROW/ in close vicinity:

- i. Route and types of foreign service/pipeline in and around or crossing the right of way (including those existing and those which are likely to come up during contract execution or any abandoned pipelines).
- ii. Diameter, wall thickness, pressure, pipeline coating against corrosion, soil cover used in case of pipelines.
- iii. Details of the existing pipeline Cathodic protection systems protecting the services i.e. location, rating, type of protection, anode beds, test station locations and their connection schemes.
- iv. Graphical representation of existing structure/pipe-to-soil potential [P-S-P] records, T/R unit current/ voltage input/output ratings, present current/Potential Input/Output Data etc for the existing pipelines.
- v. Remedial measures existing on foreign pipeline/ services to prevent interaction.
- vi. Possibility of integration/ isolation of existing CP systems, which may involve negotiations with owners of other existing pipeline services.
- vii. Crossing and parallel running of electrified and non-electrified traction (along with information regarding operating voltage, type AC/DC etc.) as well as abandoned tracks near ROW having electrical continuity with the tracks in use.
- viii. Crossing or parallel running of any HT AC/DC overhead line (existing/proposed) along with details of distance from pipeline, voltage, type AC/DC, distance from pipeline of earthing of towers etc.
- ix. Voltage rating, number of cores and sheathing details of underground power cables, along ROW or in it's vicinity.
- x. Information on existing and proposed DC/AC power sources and system having earth as return path, in the vicinity of the entire pipeline route such as HV DC sub stations, fabrication yards with electric welding etc.

	<b>TECHNICAL SPECIFICATION FOR TCP &amp; PCP</b>	<b>Document No.</b>	<b>Rev</b>
		11-0330G01-02-10-02-101	0
		<b>SHEET 8 of 49</b>	

xi. Any other relevant information that may be needed in designing and implementing proper protection scheme for the proposed pipeline.

Unless otherwise mentioned, CP contractor shall conduct necessary potential gradient survey for any existing anode ground bed that may interfere with the CP system of the pipeline covered under this project.

**CP DESIGN REPORT**

On completion of all field work a composite report incorporating all the results generated from site surveys for data generation and details of additional data collected and complied with in the attached Compliance Report format clause wise as above shall be furnished to owner for Approval. The report shall also contain detailed interpretation of survey results and resistivity data enclosed, probable interference prone areas etc. to form design basis for the scheme of Cathodic protection [TCP] & [PCP] system. This report shall also include various drawings prepared in connection with the above work. The soil resistivity values shall be plotted on semi-log graph sheets and in Histograms. Log mean resistivity values to be calculated and used for the Design of CP system.

The Cathodic Protection Design of [TCP] and [PCP] systems should be part of this composite Report. The Bill Of Materials [B.O.M.], Technical Specifications, Vendor list [from listed herein] etc. will be included in this Report for Approval of Owner. The Drawings for Owners Approval shall be part of this composite report.

**4. CATHODIC PROTECTION DESIGN PARAMETERS**

Unless expressly varied and otherwise specified in the project specifications, following parameters shall be used for design of temporary Cathodic protection [TCP] system and permanent Cathodic protection [PCP] system.

**4.1** Those parts of sacrificial anode Cathodic protection [TCP] system which will be integrated with permanent CP system [PCP] such as Reference Cu-CuSO<sub>4</sub> electrodes, Test Lead Points, Junction Boxes, Thermitwelds epoxy encapsulation, Markers, Polarization coupons etc. shall be designed based on permanent CP parameters.

**4.2. PROTECTION CURRENT DENSITY**

Pipelines having polyethylene coating.

Pipeline surrounding	Protection Current density *	
	Temporary CP (μA/m <sup>2</sup> )	Permanent CP (μ A/m <sup>2</sup> )

Normal soil	25	25
Marshy area	35	35
High resistivity area (more than 100 Ωm)	20	20

However, the Protective Current Density to be chosen at site as per measured Environmental conditions obtained as per Detailed Chemical & Microbial Analysis and presence or absence of interfering elements in close vicinity of GAIL pipeline ROW.

**Pipe to soil potential shall not be more negative than (-) 1.5V (“ON”) or (-) 1.18V (“Off”) w.r.t. Cu-CuSO<sub>4</sub> Reference electrode.**

\*Actual current density to be adopted shall be decided based upon soil/water corrosivity and other environmental conditions, proximity of foreign pipelines and structures resulting in interference. Where considered necessary for satisfactory protection of pipeline the current density shall be suitably increased by contractor with appropriate justifications.

#### 4.3. OTHER PARAMETERS FOR DESIGN

Other parameters to be considered for [TCP] and [PCP] design:

- 4.3.1. Safety Factor for Current Density : 1.3
- 4.3.2. Anode Utilization Factor : 0.85 for centre connected Anode  
: 0.5 for Ribbon Anode
- 4.3.3. Pipeline natural potential (-) 0.45V [as measured from existing /upcoming structure in the same soil matrix].
- 4.3.4. Unless otherwise specified in project specification the design life of [TCP] temporary CP shall be (1) year or commissioning of PCP whichever is latter and that of [PCP] permanent CP shall be (40) Forty years.
- 4.3.5. Along the ROW where soil resistivity is higher than 100 Ω m temporary CP for the pipeline may not be necessary subject to Owner’s Approval.
- 4.3.6. Steel Resistivity  $2.2 \times 10^{-7} \Omega M$
- 4.3.7. Maximum Loop Resistance 1 Ω

#### 5. CATHODIC PROTECTION DESIGN CRITERIA

Cathodic protection system shall be designed to meet the following criteria.

##### 5.1 TEMPORARY CATHODIC PROTECTION [TCP]



TECHNICAL SPECIFICATION  
FOR TCP & PCP

Document No.

11-0330G01-02-10-02-101

SHEET 10 of 49

Rev

0

- 5.2. The pipe to soil potential measurements shall be between  $-0.95V$  ("On") and  $-1.5V$  ("On") both "On" Potentials w.r.t.  $Cu-CuSO_4$  reference electrode. In case sulphate reducing bacteria [SRB] are present in soil the minimum protective potential shall be  $(-) 0.95V$  ("On"), the maximum remaining the same  $(-) 1.5V$  ("On") w.r.t.  $Cu-CuSO_4$  reference electrode. At the location of Polarization coupons, the coupon to soil potential measurement shall be between  $(-) 0.95$  ("Off") minimum and  $(-) 1.18 V$  ("Off) maximum w.r.t.  $CuCuSO_4$  reference electrodes, both being "Off" potential. During [TCP] monitoring using Reed Magnetic switch "Off" potentials to be recorded.
- 5.3. In rare circumstances a minimum polarisation shift of  $(-) 100$  millivolts w.r.t.  $Cu-CuSO_4$  reference electrode shall indicate adequate levels of cathodic protection for the pipeline.

**Discretion to use any of the criteria, listed above, shall solely rest with the Owner/ Owner's representative.**

- 5.4. A positive potential swing of  $>20$  mV [P-S-P] shall be considered as the criteria for presence of an interaction situation requiring investigation and incorporation of suitable mitigation measures by the C P Contractor.

**PERMANENT CATHODIC PROTECTION [ P C P ]**

- 5.5. The pipe to soil potential measurements [PSP] shall be between  $(-) 0.95V$  ("Off") minimum and  $(-) 1.18V$  ("Off") maximum [both "Off" Potentials] w.r.t.  $Cu-CuSO_4$  reference electrode, the maximum remaining the same  $(-) 1.5V$  ("On") w.r.t.  $Cu-CuSO_4$  reference electrode. At the location of Polarization coupons, the coupon to soil potential measurement shall be between  $(-) 0.95$  ("Off") minimum and  $(-) 1.18 V$  ("Off") maximum w.r.t.  $CuCuSO_4$  reference electrodes [both being "Off" potential].
- 5.6. In rare circumstances a minimum polarisation shift of  $(-) 100$  millivolts w.r.t.  $Cu-CuSO_4$  reference electrode shall indicate adequate levels of Cathodic protection for the pipeline.
- Discretion to use any of the criteria, listed above, shall solely rest with the Owner/ Owner's representative.
- 5.7. A positive potential swing of  $>20$  mV [P-S-P] shall be considered as the criteria for presence of an interaction situation requiring investigation and incorporation of suitable mitigation measures by the C P Contractor.

**6. SYSTEM DETAILS**

**6.1 Temporary Cathodic Protection [TCP]**

	<p align="center"><b>TECHNICAL SPECIFICATION FOR TCP &amp; PCP</b></p>	Document No.	Rev
		11-0330G01-02-10-02-101	0
		SHEET 11 of 49	

The [TCP] system unless specified otherwise, may include the following major equipment/ sub-systems.

- Sacrificial anodes [Zn or Mg] ground beds in carbonaceous back-fill
- Test stations [TLP]
- Junction Boxes with shunts and resistors [AJB] & [CJB]
- Permanent Reference Cu-CuSO4 Electrodes [CSE]
- Pin Brazing epoxy encapsulated
- Surge diverter/ Grounding cell at Insulation Mono – blocks, or
- Grounding cell at Insulation mono - blocks
- Solid state DC Decoupling device at A.C. Interference locations
- Earthing of Motor Operated Valve [MOV] and other Electrical equipments without disturbing CP System through Sacrificial anodes
- Polarization ER Coupons for corrosion monitoring
- Interconnecting cables
- Cable to pipe connections-Pin Brazing.
- Markers for Cable, Anode bed etc.
- CP System at Cased Railway Crossings

**6.2 PERMANENT CATHODIC PROTECTION [P C P]**

The [PCP] system may include the following major equipment/ sub-systems unless otherwise specified.

- Digital Power Source AC Input DC Output [TRU] with built-in Current interrupter and GPS based timer.
- Distribution Board [dB]
- MMO [LIDA Single] anodes and anode ground beds in carbonaceous back-fill
- Test stations [TLP]
- Computerized Test Stations [CTSU]
- 
- Junction Boxes with shunts and resistors [AJB] [CJB]
- Permanent Reference Cu-CuSO4 Electrodes [CSE]
- Pin Brazing for pipe to cable connection [ epoxy encapsulated ]

	<b>TECHNICAL SPECIFICATION FOR TCP &amp; PCP</b>	Document No.	Rev
		11-0330G01-02-10-02-101	0
		SHEET 12 of 49	

- Surge diverter/ Grounding cell across Insulation Mono - blocks
- Grounding cell at Insulation mono - blocks
- Solid state DC De-coupling device at A.C. Interference locations
- Polarization ER Coupons for Corrosion monitoring
- Interconnecting cables
- Cable to pipe connections.
- Markers [for cable route, anodebed etc.]
- Insulating fittings

### 6.3 SITE CONDITIONS

The equipment will be designed for the following site conditions:

Min/Max. Temperature	0 <sup>0</sup> C to 60 <sup>0</sup> C
Design Temperature	65 <sup>0</sup> C
Relative Humidity	90%
Height above MSL	< 1,000 M
Atmospheric Pollution	To withstand the site conditions, dust, vapour
Hazardous area classification for plant	Zone 2, Gas Group IIA, IIB
	Temp. Class T3
Control Room/Electrical Room/	
D.G.Room/Guard Room/Battery Room	Safe Area

### 6.4 EQUIPMENTS

All equipment shall be new and supplied by CP contractor sourcing from approved manufacturers of repute with proven track record and approved by the owner for the supply for this project. Equipment offered shall be field proven. Equipment requiring specialised maintenance or operation shall not be acceptable hence should be avoided, as far as possible, and prototype equipment shall not be accepted. Make and construction of all materials shall be subject to owner's approval.

The detailed specification of each system and equipment shall be furnished by the contractor. However, certain minimum requirements for the major equipment are highlighted in this document.

#### 6.4.1 Equipment Location In Hazardous / Non Hazardous Area



**TECHNICAL SPECIFICATION  
FOR TCP & PCP**

**Document No.**

11-0330G01-02-10-02-101

SHEET 13 of 49

**Rev**

0

As far as possible equipment including Power source, test stations, anodes, junction boxes, TLP etc. shall be located in safe area. However, **all equipment located in hazardous areas shall be of flame proof type as per BIS: 2148, IEC 79 for gas groups IIA & IIB and temp. Class T3 (200<sup>o</sup> C).**All equipment to be located in Hazardous area should conform to and comply with BIS 2148 and IEC 79 (or equivalent) code requirements. All indigenous flame proof equipment should be certified by **CMRS**. All flame proof equipment of indigenous origin should also be **BIS** marked.

**7. ANODE GROUND BEDS**

**7.1 TEMPORARY CATHODIC PROTECTION [TCP]**

- 7.1.1 Along ROW where soil resistivity predominantly remains low and ranges from 0-10 Ω m Zinc (Zn) anodes shall be provided. However, at locations where soil/water pH is more than 9, Zn anodes not to be used as these get Passivated.
- 7.1.2 Along ROW where soil resistivity is predominantly higher than 10 Ω m Magnesium (Mg) anodes shall be provided.
- 7.1.3 At high resistivity area where resistivity is of the order of 50 Ω m and above Magnesium (Mg) ribbon anodes shall be provided.
- 7.1.4 Anodes shall be installed along the pipeline at suitable intervals as per pipeline protection voltage attenuation calculations and ground bed resistance/current output of anode installations.
- 7.1.5
- 7.1.6 Each electrically continuous section of pipeline shall preferably be protected totally by one type (material) of anodes [either Zn or Mg] to avoid inter-anode [Zn ↔ Mg] circulation currents. Grounding cell should also conform to this specific requirement.
- 7.1.7 The anodes shall be installed at sufficient depth to reach perennially moist soil [ascertained by ground water table data] but minimum 2M depth from grade level and shall be separated linearly from the pipe line by at least 5m and 2m for Magnesium (Mg) and Zinc (Zn) anodes respectively. The ribbon anodes should be laid at least 0.5 M away from pipe. The anode connections to pipe line shall be routed through test stations.
- 7.1.8 However, environment suitability [such as pH, excessive carbonate, bi-carbonates, sulphates, chlorides, nitrates etc. which could result in anode passivation] should be checked prior to lowering of sacrificial anodes suitability in the anodebeds. Zn should not be used if soil/water pH is over 9.
- 7.1.9 At the temporary CP anode ground bed, the leads of all the anodes shall be connected individually through Shunt and Resistor [for controlling each anode output individually] in the TLP/ junction box.
- 7.1.10 For sacrificial anode ground beds which shall be integrated with permanent CP system the leads of all the anodes shall be brought up to the test station and shall be terminated individually with shunts inserted in between so that individual anode current output can be regulated & measured as required.

	<p align="center"><b>TECHNICAL SPECIFICATION FOR TCP &amp; PCP</b></p>	<b>Document No.</b>	<b>Rev</b>
		11-0330G01-02-10-02-101	0
		SHEET 14 of 49	

7.1.11 For Sacrificial anode CP system the Anodes shall be supplied with Tail cable [6 mm<sup>2</sup> PE PVC copper conductor single core multistrand cable] of sufficient length so as to reach Junction box, for termination, without difficulty. No joints are permissible on the cable run from anode tail to junction box.

7.1.12 The tail cable connection with the Iron Insert of Cable should be tightly done followed by Epoxy encapsulation so as to ensure that no Necking takes place which could result in snapping of cable connection due to spark. Anode cap of heat shrinkable PE material should be able to ensure this.

## 7.2. PERMANENT CATHODIC PROTECTION [P C P]

7.2.1. Anodebeds To be installed at every CP Station and located at least 100 M away from pipeline ROW to ensure adequate remoteness which should also be calculated.

7.2.2. All [MMO] Anodes to be placed in Petroleum coke breeze, in appropriate [shallow –horizontal or vertical, or semi-, deep well, deep well] configuration as per design to achieve requisite circuit resistance and protective Current output throughout the [40 years] service life. However, anode bed configuration selected should be technically justified.

7.2.3. The MMO anode should be supplied with sufficient length of 10 mm<sup>2</sup> XLPE PVC cable so as to run up to junction box for termination in the junction box without in-between joints. No joints are permitted in cable run from Anode tail to junction box. This cable size is minimum only and wherever necessary, for appropriate operation of the CP system, higher sized cables should be provided.

7.2.4. Appropriate tamping of carbonaceous backfill [petroleum coke breeze ] should be done so as to ensure appropriate compaction around [MMO] anode.

7.2.5. Anodebed Plot: CP contractor shall acquire[for GAIL] & make available a plot of land measuring minimum 8 M X 8 M in size & at least 100 M away from pipeline ROW for locating anodebed,at each Anodebed location along the pipeline ROW. CP Contractor to indicate the location of anodebeds along pipeline ROW and mark it on As-Built Drawings and handover the requisite ownership documents to GAIL at the time of Handing over of the system.

## 8. ANODES

### ❖ SACRIFICIAL ANODES

#### 8.1 MAGNESIUM ANODE

The anode shall be of low voltage (-) 1.5 V type Magnesium [Mg] alloy packed in special back fill and suitable for use with three layer extruded polyethylene coating. The anode to conform to ASTM B 843 specifications such as the metallurgical composition, potential and consumption rate of anode shall be as below:

xii. Composition:



TECHNICAL SPECIFICATION  
FOR TCP & PCP

Document No.

11-0330G01-02-10-02-101

SHEET 15 of 49

Rev

0

Element	Weight
Manganese	0.15 – 0.7%
Copper	0.02% max.
Silicon	0.10% max.
Zinc	2.5 – 3.5%% max.
Aluminium	5.3 – 6.7% max
Iron	0.003% max
Nickel	0.002% max
Other metallic elements	
- Each	0.05% max.
- Total	0.3% max.
Magnesium (Mg)	Balance

- xiii. Anode open circuit potential (-)1.5 volts. W.r.t. CSE
- xiv. Anode consumption rate 7.9 kg / (A Yr) Max.

**8.2 ZINC ANODE**

The Zinc [Zn] anode shall conform to ASTM B 418 standard. The anode (other than ribbon anode) shall be packaged with special back fill. The metallurgical composition of anode, potential and consumption rate shall be as below:

Composition:

Element	Weight
Aluminium	0.3 – 0.5% max.
Cadmium	0.075-0.1% max.
Copper	0.005% max.
Iron	0.002% max.
Silicon	0.005% max.
Lead	0.005% max.
Zinc	Remainder

Anode open circuit potential (-) 1.1 volts w.r.t. CSE



Anode consumption rate 11.24 kg / (A yr) Max.

8.3 Contractor shall furnish spectrographic analysis from each heat both for Zinc (**Zn**) and Magnesium (**Mg**) anodes along with electrochemical test results .CP Contractor shall mention specifically the method of Spectrography (Atomic Absorption/Emission Spectrometry/Photometrics) for Owner's Approval.

**8.4 SPECIAL BACKFILL FOR SACRIFICIAL ANODES**

The composition of special backfill for sacrificial anodes shall be as below:

Gypsum	75%
Bentonite	20%
Sodium sulphate	5%

8.5 Some Specific Requirements for sacrificial anodes are as follows:

The anodes shall be provided with cable tail of sufficient length to reach junction box/test station [TLP] as applicable in single run without tension and without in between joints.

**8.5.1. TOLERANCE IN FABRICATION OF SACRIFICIAL ANODES**

Visual Inspection shall be carried out on all the Anodes regarding surface finish, excessive shrinkage, cracks, cable joint to anode core etc.

- The anode surface shall be free from cracks (which may reduce the performance of the anode.).
- Any cracks which follow the longitudinal direction of elongated anodes shall not be acceptable.
- Small cracks in the transverse direction of elongated anodes and in anodes of other shapes may be accepted provided the cracks would not cause any mechanical failure during service of the anode considering that the combination of cracks and lack of bond to the anode core is detrimental.
- For transverse cracks the acceptable limits shall be furnished by the bidders along with the offer.
- The anode shall be free from excessive shrinkages. The following limits shall be used.

Maximum 10% of the depth of anode or 50% of the depth of the anode core whichever is less. The depression may be measured from the edges of one side.

- The surface of the anodes shall be free from coatings and slag/ dross, inclusions etc.
- The maximum deviation from straightness shall not exceed 2%.
- The weight tolerance on individual anodes may be taken as ± 5%. The total weight of the anodes shall not have negative tolerance.
- Recommended dimensional tolerance shall be as follows:



<b>Document No.</b>	<b>Rev</b>
11-0330G01-02-10-02-101	0
SHEET 17 of 49	

Length ± 2.5%

Width/ thickness ± 5%

- One Anode per heat shall be radiographed to evaluate slags, voids, inclusion etc.
- At least 10% number of Anodes from each heat to be checked for conformity to Dimensions & Weight.
- One Anode, at least shall be Tested Destructively to check bond between Anode material and steel insert, slag, inclusion etc. Failure of one anode during the test shall make the entire anode lot liable for rejection.

## FOR PERMANENT CATHODIC PROTECTION [P C P]

### 8.6 Mixed Metal Oxide [MMO] Anodes: LIDA SINGLE

The Permanent Cathodic Protection [PCP] system will have Mixed Metal Oxide [MMO] Strip Anodes also known as LIDA [Linear Distributed] Anodes and LIDA single. The [MMO] LIDA single anodes shall be centre connected sealed tubular type. These Anodes shall be of Noble metals [group VIII] Mixed Metal Oxide coated Titanium [having Ti substrate composition conforming to ASTM B 338 Grade I and/or Grade II]. The LIDA [MMO] anodes shall be dimensionally stable.

The characteristics of the [MMO] LIDA single anodes are as follows:

- Shape and Dimension
  - 1,000 mm ± 5 mm long
  - 25 mm ± 0.2 mm wide
  - 3 mm ± 0.1 mm thick
- Weight 0.27 Kgs ± 0.020 Kgs. Recommended Maximum

### OPERATING CURRENT DENSITY

- With Carbonaceous Backfill 75 Amp / M<sup>2</sup>
- Current Output with Carbonaceous Backfill 3 Amp /M<sup>2</sup>
- Electrical Resistivity 6 x 10<sup>-5</sup> Ω cms.
- Type of Joint Epoxy Splicing
- Contact Resistance of Anode to Cable joint 9 x 10<sup>-5</sup> Ω {maximum}
- MMO Coating thickness ≥ 6 gms/M<sup>2</sup>
- Anode Consumption Rate 1 mg/Amp. Yr.
- Type of Cable XLPE PVC 10 mm<sup>2</sup>
- Length of Cable As Required so as to reach JB
- Design Life 40 Years
- The Anodes shall be provided Bare for Deep well, and with sheet steel canisters and petroleum coke breeze for shallow bed configuration



TECHNICAL SPECIFICATION  
FOR TCP & PCP

Document No.

11-0330G01-02-10-02-101

SHEET 18 of 49

Rev

0

- The Anodes to be Installed at a distance of 5m (Minimum) apart and shall be **electrically remote to the pipeline [to be ascertained by calculations]**. Normally the nearest part of anode for shallow horizontal/vertical type of anode beds shall not be less than 100M from the pipeline. However, the actual distance will be as per site conditions. For Deep well anode bed the first anode should be at least more than 15 M deep [as per NACE RP 0572 Standard] and the actual depth shall be as per Approved Design. However, for Deep well Anode bed also LIDA Single [MMO] anodes (& not LIDA String Anodes) shall be used.
- Anode LIDA [MMO] Single to cable [XLPE PVC 10 mm<sup>2</sup>] jointing and insulation shall be done by anode manufacturer at MMO anode fabrication shop.
- Dimension & weight of all anodes to be checked & recorded. Negative tolerance will not be acceptable.
- Routine & type test certificates of cable manufacturer to be furnished for anode lead cable as per IEC 502 – 1983 or relevant BIS code. Length and identification tag to be verified by measurement
- Each anode to cable joint shall be tested for it's electrical contact resistance & its value in  $\Omega$  shall be recorded.
- First Anode to cable joint shall be subjected to accelerated ageing test & destructive test to determine pullout strength of cable to anode joint as well as effectiveness of the joint insulation.
- Manufacturer shall furnish detailed dimensioned fabrication drawing of anodes as well as details of cable connection& it's insulation sealing to owner for approval. Manufacturer of anode will commence only after this Approval from owner.
- Vendor shall furnish, for Owner's Approval, the following information
  - type & make of Heat Shrink cap & it's properties
  - procedure for making the joint
  - procedure for accelerated ageing test
  - Vendor shall submit all test reports for Owners review.

**9.0 PETROLEUM COKE BREEZE**

Lubricated calcined petroleum coke breeze backfill material for use with LIDA Single [MMO] Anodes in [PCP] system shall have a carbon content of 91.77% minimum and a bulk density of 74 pounds per cubic ft. Zero percent shall be retained by a screen size of 16 mesh.

	<b>TECHNICAL SPECIFICATION FOR TCP &amp; PCP</b>	Document No.	Rev
		11-0330G01-02-10-02-101	0
		SHEET 19 of 49	

The coke breeze shall have low resistance carbon lubricant added for lowering the combined resistance while developing the pumping qualities. Earth contact resistance shall be 0.1  $\Omega$  cm at 150 PSI.

**BACKFILL DATA SHEET**

Carbon	91.770%
Volatiles	00.700%
Ash	02.230%
Sulphur	05.850%
Silicon	00.060%
Iron	00.020%
Moisture	00.000%

**TYPICAL PARTICLE ANALYSIS**

Screen Size	% Retained	% Retained (Cumulative)
16 Mesh	00.000	000.00
28 Mesh	02.100	002.10
48 Mesh	21.100	023.20
100 Mesh	60.300	083.50
200 Mesh	15.000	099.50
200+Mesh	01.500	100.00

**TYPICAL PHYSICAL ANALYSIS**

Bulk Density	54 lb/cu ft.
Real Density	02 gm/ml
Porosity	40.8%

- ❖ The Petroleum Coke Breeze Material shall be tested for chemical composition, bulk density, real density, particle size and resistivity, sieve analysis.

**10.0 AC OPERATED AUTO/MANUAL TRANSFORMER RECTIFIER UNIT [TRU]**

The TRU shall be supplied in accordance with the following specifications and Data sheets:

	<b>TECHNICAL SPECIFICATION FOR TCP &amp; PCP</b>	Document No.	Rev
		11-0330G01-02-10-02-101	0
		SHEET 20 of 49	

**10.1 GENERAL DESCRIPTION**

This specification covers the requirements of design, manufacture, inspection, testing and supply of Automatic Controlled Transformer Rectifier Unit for Cathodic Protection of underground structures. Reliability of equipment and ease of maintenance is of utmost importance. The workmanship shall be of highest grade and entire design and construction in accordance with the best modern practice. The C.P. Units shall be capable of continuous trouble free operation at full load rating specified. The protection devices and control components shall be of standard design and carefully chosen to meet the requirements of the sets.

All similar materials and parts of similar equipments shall be interchangeable with each other. Special care shall be exercised in the design and manufacture for aging effects, low input voltage, DC voltage fluctuations, high forward current through the rectifying elements and high temperature conditions during operation.

Apart from the derating for site conditions an additional derating of 20% shall be considered for the specific use. The components of the units shall be designed for maximum operating efficiency. The C.P. Units shall be provided with all the necessary protections required as detailed in the following pages. The C.P. Units shall have Automatic/Manual control and shall be metal clad, compact, indoor installation type, air natural cooled, dust and vermin proof systems exactly conforming to the following specifications and no deviations shall be allowed.

**10.2 TECHNICAL REQUIREMENT**

10.1.1 The CP Transformer Rectifier Units' scheme for protection, monitoring, control, metering and indication shall be designed to meet requirements of this specification. The control shall be achieved using thyristors and fully solid state logic only. The various features of the unit will be as per the details provided in the data sheet in this specification.

10.1.2 Transformer shall be of double wound, air cooled type with an electrostatic shield between the windings. The transformer insulation shall be Class F. The winding size shall be based on maximum current density of 1.6 Amps/sq. mm of copper conductor.

10.1.3 Rectifier shall be silicon type of approved make with adequate cooling arrangement and with moisture and humidity resistant finish. It shall be mounted on spindles or other suitable supports. It shall have configuration suitable for full wave rectification. Adequate filtering in the form of L-C filtering circuit shall be provided on output side to smoothen out the D.C. output to limit ripple content to less than 5% at rated output.

The input and output of rectifier shall be protected by fast acting fuses of suitable ratings. Lightning Arrestors/Surge Suppressors shall also be provided across D.C. output terminals and A.C. input terminals to protect the rectifier against surges. Each diode and SCR shall be provided with suitable surge suppressers.



<b>Document No.</b>	<b>Rev</b>
11-0330G01-02-10-02-101	0
SHEET 21 of 49	

The T/R unit shall be provided with two modes of working as under. A mode selector switch shall be provided to select the desired mode of operation. Both the modes shall be independent of each other and failure of the unit in one mode shall not affect working of the unit in other mode. A brief description of these modes is given below.

**A) Auto Ref. Mode**

The unit will be generally working in this mode. The operation of the unit in this mode shall be controlled by a reference signal. The output D.C. voltage of the unit in this mode shall vary right from 0V to rated voltage and from 0A to rated current to maintain the reference signal within  $\pm 20$  mV of the set value under all operating conditions. The response of the unit shall be instantaneous to suppress extremely fast acting external stray currents if present. The typical reference regulation in this mode shall be within  $\pm 20$  mV under all conditions.

Fully solid state Automatic Reference Selector logic shall be provided to select the lowest of the Three Reference Inputs automatically. Facility shall also be provided for Manual selection of any one out of the three reference inputs for control. Suitable metering arrangement shall also be provided to monitor all the three external reference signals as well as the internal reference signals independently.

In the event of failure of all the reference signals, the unit will provide alarm - " All Reference Fail" and the output of the unit shall get adjusted to a preset value, which will be operator adjustable from 0V to rated voltage.

Independent ultra fast acting electronic current limit circuit shall be provided to limit the output current of the unit in Auto mode to any value from 0 A to rated value as desired by the operator. The current limit circuit will be capable of protecting the unit even under dead short circuit across output. The unit will be capable of sustaining dead short circuit across output indefinitely without degrading or damaging any internal components in this mode.

**B) Automatic Voltage-Current Control mode (AVCC mode)**

This will be the second mode of operation. The working of this mode shall be totally independent of the Auto mode and failure of the unit in Auto mode shall not affect operation in this mode.

The output voltage of the unit shall be adjustable to any value from 0V to rated voltage by means of a stepless voltage setter. The set voltage shall be maintained within  $\pm 0.25$ V of the set value for change in DC input voltage within specified limits and change in load from 0A to full load.





- Reference 2 Lowest - LED indication
- Reference 3 Lowest - LED indication
- Reference 1 Fail - LED indication
- Reference 2 Fail - LED indication
- Reference 3 Fail - LED indication
- All Reference Fail - LED indication
- Overcurrent (Current Limit) - LED indication
- Unit Working in Auto Mode - LED indication
- Unit Working in AVCC Mode - LED indication
- Unit Working in Local Mode - LED indication
- Unit Working in Remote Mode - LED indication

#### 10.3.1.2 Local Control

Facility will be provided for local control of following:

- O/P Voltage - By means of potentiometer on panel
- DC O/P Current - By means of potentiometer on panel
- PSP - By means of potentiometer on panel
- Selection of Auto/AVCC Mode - By means of selector switch on panel
- Start/Stop of Current Interrupter - By means of Keypad on Timer

#### 10.3.2 REMOTE MONITORING & REMOTE CONTROL

The T/R unit will be suitable for Remote Monitoring & Remote Control through the RTU/SCADA system. For this purpose Programmable Logic Control system (PLC) shall be provided in the existing TR unit. The PLC shall interface all the remote control and monitoring signals of the TR with RTU/SCADA. The PLC shall be of a reputed and proven brand like Allen Bradley, Siemens, GE, Schneider, and Mitsubishi. PLC of any unknown and non-proven make will not be acceptable.



The system shall comprise of Processor, I/O system, communication sub-system, power supply and serial link communications to RTU, including 10 meters of serial interface cables along with all necessary connectors at both ends for communication to RTU. The system shall include all accessories like isolators, relays, terminals, etc as per the specifications along with software and all other necessary hardware, etc required for proper operation of the PLC system.

The design and the component used for the PLC system shall provide maximum reliability, maximum on-line performance and minimum maintenance. All items shall be field proven. No prototype item shall be supplied.

The PLC shall not be damaged due to power failure. In case of power failure the PLC shall be able to retain the control settings prior to power failure and set accordingly on resumption of power.

The system shall be modular in construction and expandable in future by adding additional modules, which shall be easily accessible for maintenance and repair. The types of modules shall be kept to minimum possible in order to have inter-changeability and low spares inventory.

The PLC shall have a very high noise immunity in order to ensure safe and reliable operation when subjected to electrical radio frequency interference and electro magnetic disturbances expected from other electrical/electronic equipment located near by and inside the TR unit panel.

The communication subsystem shall be a digital communication bus that provides reliable and high speed data transfer between the processor subsystem, I/O subsystem, PLC display, or other devices connected to the system.

**10.3.2.1 SYSTEM SOFTWARE**

The vendor will supply the necessary system software such as all programs for the PLC, PLC display etc. which are required to perform all the PLC functions including communication and self-diagnostics. Logic program with necessary instructions shall be recorded on compact disc (CD) and shall be delivered with the system.

The PLC system shall be rated for 24 V DC power supply voltage. The 24 V DC power supply shall be derived from 230V AC power supply for the TR unit, through a suitably rated 24 V DC Power supply module.

The PLC and the DC for power supply module for the PLC shall be mounted inside the TR Unit panel.

**10.3.2.2 PARAMETERS FOR REMOTE MONITORING**

Facility will be provided for remote monitoring of following:

	<p align="center"><b>TECHNICAL SPECIFICATION FOR TCP &amp; PCP</b></p>	<b>Document No.</b>	<b>Rev</b>
		11-0330G01-02-10-02-101	0
		SHEET 25 of 49	

**A) Analog Signals**

- DC Output Voltage - Hardwired
- DC Output current - Hardwired
- Lowest/Selected PSP - Hardwired

**B) Digital Status Signals**

- Pipeline Underprotection - Through PLC / RS 485
- Pipeline Overprotection - Through PLC / RS 485
- All Reference Fail - Through PLC / RS 485
- Unit Working in Auto Mode - Through PLC / RS 485
- Unit Working in AVCC Mode - Through PLC / RS 485
- Unit Working in Local Mode - Through PLC / RS 485
- Unit Working in Remote Mode - Through PLC / RS 485

**10.3.2.3 PARAMETERS FOR REMOTE CONTROL**

Facility will be provided for Remote control of following:

- Setting of DC O/P Voltage - Through PLC / RS 485
- Setting of DC O/P Current - Through PLC / RS 485
- Setting of PSP - Through PLC / RS 485
- Selection of Auto/AVCC Mode - Through PLC / RS 485
- Start/Stop of Current Interrupter - Through hard wired potential free contact from RTU/SCADA

**10.4 RELIABILITY AND FACTOR OF SAFETY**

Due to very harsh conditions under which the units are going to operate, prime importance shall be given to ensure reliability and trouble-free operation. To take care of high transient voltages and high peak current demands adequate factor of safety shall be provided in choosing all the components. Minimum factor of safety to be provided for critical components is as under.

Components	Factor of Safety
------------	------------------

All wound components : 50% additional capacity

**Components****Factor of Safety**

Thyristor & diodes	: PIV : 1200V minimum  : $I_{av}$ : At least 3 times actual max. average current at full load.
Passive components like switches, resistors	: 50% safety margin in current rating.
Overall system	: The unit shall be capable of delivering 125% rated current output at rated voltage for 1 hour.
Electronic Control	: The entire electronic circuitry shall be assembled on plug-in type glass epoxy PCBs. The control circuit shall be designed using the latest advanced ICs to minimize the component count. Status indicator LEDs shall be provided on each control card to indicate functioning of the card. All the control cards shall be completely sealed using protective coatings.  The control circuit shall be capable of operating at elevated temperatures of upto 70 °C without any degradation in performance or life expectancy.

**10.5 WORKING LIFE**

The TR Unit shall be designed for a working life of minimum 35 years.

**10.6 TECHNICAL SPECIFICATIONS AND DATA SHEET – TR Unit**

- |  |   |
|--|---|
| A) A. C. Input Voltage                 | : 230V $\pm$ 10%, 1Ph, 50 Hz $\pm$ 5%, AC |
| B) A. C. Input Current                 | : 8.0 A (max)                             |
| C) D. C. Power Output                  | : 625W                                    |
| D) D. C. Output Voltage                | : 0 to 25V DC                             |
| E) D. C. Output Current                | : 0 to 25A DC                             |
| F) Controls                            | : 1. Auto PSP<br>2. AVCC (Manual)         |
| G) Full load efficiency of the TR unit | : Not less than 70%                       |



**TECHNICAL SPECIFICATION  
FOR TCP & PCP**

**Document No.**

11-0330G01-02-10-02-101

SHEET 27 of 49

**Rev**

0

- H) Power Factor at full load : Better than 0.8 Lag
- I) Insulation Level : 2 KV for 1 minute
- J) Cable entry : A.C. input, D.C. output, Ref. Cells and Alarm cables. From the bottom plate of the unit, thru suitable cable glands.
- K) Filtering circuit : L. C. Filter
- L) Ripple & Hum : Less than 5% at rated load
- M) Surge Diverters for diodes/SCRs/Transistor : Metal oxide varistors / capacitors / R-C Networks
- N) Lightning Arrestor : At both input & output side of the unit  
R.M.S. Voltage Rating : 500V  
R.M.S. Current Rating : 1.5KA  
Type : LT 0.5 or Eqv.
- O) Protection : - 2 pole MCB in AC input for overload protection & Isolation.  
- 2 pole MCB in DC output.  
- HRC fuses in input & output.  
- Glass cartridge fuses in the live line of all lamps, auxiliary power lines to control circuit.  
- Built in electronic current limit and short circuit protection feature.  
Current limit adjustable from 0 to rated value.  
- All reference fail indication and automatic setting of O/P DC voltage to preset value.
- P) Ref. Fail Safe Feature : In the event of failure of all the Reference Electrodes the unit will provide "All Reference Fail" indication and the DC O/P voltage will get adjusted to a programmable preset value.
- Q) Reference Electrode : 3 Nos. Cu/CuSo4  
[Permanent] Automatic Reference Selector Logic shall be provided to automatically select the lowest (least protected) reference signal out of three reference signals fed to the unit simultaneously.  
Facility shall also be provided to select one out of three ref.



**TECHNICAL SPECIFICATION  
FOR TCP & PCP**

**Document No.**

11-0330G01-02-10-02-101

**SHEET 28 of 49**

**Rev**

0

- Electrodes by means of a Manually operated Reference Selector switch.
- R) Control element : The DC output will be controlled using latest solid state SCRs.  
 These SCRs will be controlled by the commands from the control circuits.  
 All the electronic circuits will be assembled on plug-in type control cards.
- S) Modes of operation : Following modes of control shall be provided.  
 a) Auto Ref. Mode:  
 The operation of the unit in this mode will be fully Automatic and will be controlled by the Reference electrode feedback (PSP). The unit will automatically maintain Reference voltage or P.S.P. within  $\pm 20\text{mV}$  of the set value under all conditions.  
 b) AVCC Mode:  
 This will be the second mode of operation. In this mode the unit can be operated in either constant voltage or constant current mode.  
 The output voltage will be adjustable from 0 to rated value by means of stepless voltage setter potentiometer.  
 The output current will be adjustable from 0 to rated value by means of stepless current setter potentiometer.
- T) Voltage Setting Range in AVCC Mode (Manual) Mode : 0 to 25V
- U) Current Limit setting Range : 0 to 25A
- V) P. S. P. setting Range : -0.8V to -2.5V
- W) Ref. Regulation in Auto Mode : Better than  $\pm 20\text{mV}$
- X) DC Voltage regulation in AVCC (Manual) Mode : Better than  $\pm 0.25\text{V}$
- Y) Current Regulation in current limit mode : Better than  $\pm 0.5\text{A}$
- Z) Indications : a) Underprotection  
 b) Overprotection  
 c) Reference cell 1 Lowest  
 d) Reference cell 2 Lowest  
 e) AVCC mode of operation
- AA) Annunciations : a) Underprotection  
 b) Overprotection



- c) Reference cell 1 Lowest
- d) Reference cell 2 Lowest
- e) Reference cell 3 Lowest
- f) Reference cell 1 fail
- g) Reference cell 2 fail
- h) Reference cell 3 fail
- i) Reference cell All fail
- j) Overcurrent (Current Limit Mode)

- AB) Meters/Instruments : Digital Meters as under:
- AC Input Voltage : 0 to 300V AC
  - AC Input Current : 0 to 10A with CT
  - 3-1/2 Digit Digital Meters as under:
  - Output Voltage : 0 to 50V DC
  - Output Current : 0 to 50A with shunt PSP & Set PSP :  
0 to + 19.99 V DC
- AC) Local control Mode : Following controls will be provided in local mode from local control panel.
1. Setting of Ref. PSP through Potentiometer
  2. Setting of Output Voltage through Potentiometer.
  3. Setting of output current limit through Potentiometer.
  4. Auto/AVCC Mode Selection
  5. START/STOP of Current Interrupter
- AD) Remote Monitoring and control : Following features will be provided by means of PLC and  
through PLC through RS 232C / RS  
485 Serial Link RS232C / RS 485 Serial Link with MODBUS RTU Protocol.
- Digital Input status to RTU/SCADA.
1. Under Protection
  2. Over protection
  3. All Ref. Fail



4. TR unit in Auto mode

5. TR unit in AVCC mode

6. TR unit in Local mode

7. TR unit in Remote mode

Digital control signal from RTU/SCADA

1. TR unit Operation in AUTO mode

2. TR unit Operation in AVCC mode

Analog Input status to RTU/SCADA

1. Lowest/selected PSP value

2. Output DC voltage

3. Output DC current

Analog Set points from RTU/SCADA

1. Setting of PSP

2. Setting of DC output voltage

3. Setting of DC output Current

AE) Current Interruption

: Current interruption facility will be provided by means of a built-in contactor & microprocessor based fully programmable and GPS enabled Synchronisable digital timer with real time clock & ON/OFF time display. The timer will have facility for adjusting the ON time & OFF time from 0 to 999 sec. by means of front panel keypad. Timer will have START, STOP & RESET facility thru local keypad or thru remote potential free contacts.

The Timer will have typical time accuracy of + 5 PPM

Facility for interconnection of an external timer shall also be provided.

A removable bypass link will be provided for bypassing the interrupter contactor contacts.

AF) Enclosure/Construction

: Floor mounted Indoor type.

Fabricated from 1.5mm/2.0mm CRCA sheet.



TECHNICAL SPECIFICATION FOR TCP & PCP

Document No.	Rev
11-0330G01-02-10-02-101	0
SHEET 31 of 49	

Confirming to IP42 degree of protection.

Lockable doors shall be provided in the front and back.

- AG) Cooling : Natural air cooled
- AH) Painting : Baked epoxy paint/Powder Coating of shade RAL 7032 Siemens grey with proper pre-treatment and primer application as per standard Industrial Practice.
- AI) Earthing : 2 Nos. M6 earthing bolts and 1 no. nickel plated copper earth bus bar shall be provided.

### 10.6.1 MANUFACTURER'S TECHNICAL EXPERTISE & EXPERIENCE IN THE FIELD OF CATHODIC PROTECTION RECTIFIERS

The manufacturer should be a reputed and established manufacturer of CP Rectifier & CPPSM Units and should have experience in manufacturing of C.P. rectifiers & CPPSM units of similar specifications. The manufacturer will have to submit a list of C.P. Rectifier & CPPSM installations having similar specifications executed in the past 5 years, giving present working status of various units.

### 10.6.2 TESTING AND INSPECTION

The Manufacturer/Contractor shall provide all the necessary facilities to carry out full performance tests on the AC operated DC Output TR Units at his works.

### 10.6.3 GUARANTEE

The manufacturer/Contractor will have to guarantee the successful working of the units for a period of 12 months from date of Installation & commissioning.

### 11 REFERENCE ELECTRODE [CuCuSO<sub>4</sub>] PERMANENT TYPE

Permanent Copper Copper sulphate reference electrodes three (3) numbers at each CP Station and one at middle of two consecutive CP Stations are to be installed for [P-S-P] Monitoring.

One number CSE (Permanent type at each ER Probe to be installed.

### 12 TEST STATIONS [TLP]



TECHNICAL SPECIFICATION  
FOR TCP & PCP

Document No.

11-0330G01-02-10-02-101

SHEET 32 of 49

Rev

0

12.1 Test stations [TLP] shall be provided along the pipeline ROW for monitoring the performance of the cathodic protection system at intervals not exceeding 1,500 meters unless otherwise specified. In addition to above, test stations of requisite type [A, B, C, D, E or Combination of any two of these Viz: DE] shall be provided at the following locations:

- a. At both sides of major road crossings
- b. At all insulating joints
- c. At vulnerable locations with drastic changes in soil resistivity.
- d. At connections of surge diverters, grounding cells and polarisation cells.
- e. At HT AC/DC overhead line crossings and selected locations where HT overhead line is in the close vicinity of the pipeline.
- f. At railway line crossings and running parallel to the pipeline.
- g. At both sides of major river crossings.
- h. At high voltage cable crossings or along routes where HV cables are running in parallel.
- i. In the vicinity of DC net works or grounding system where interference problems are suspected.
- j. At crossings/parallel running of other pipelines/ structures.
- k. At both sides of cased crossings.
- l. At any other locations considered vulnerable/locations where interference is expected.
- m. At any other locations considered necessary by owner/ owner's representative.

Besides, every 10 Kms. Computerized Test station shall be installed for remote monitoring of the Protective Potential and Current profile.

Non Metallic [TLP] to be installed at every 1Kms. Of Salt Pan Area. For Other Areas metallic [TLP] may be provided.

12.2 Between the pipeline and foreign pipelines or structures that may exist in common ROW. Test stations for bonding shall be provided with shunt and resistor as a means to monitor and control current to ensure zero net flow of Current from one to the other.

12.1 Test stations used for sacrificial anodes shall have shunt for measurement of individual anode current, and provision of resistance to limit & control the anode current output.

12.2 Test station with current measuring facility shall be provided at each intermediate CP station drainage point ( to measure pipeline current on any one or both side of the pipeline from drainage point), at interference prone areas, on both sides of major river crossings and at least at two additional locations along the pipeline ROW between two CP stations.

12.3 All test stations shall have weather proof enclosure, having degree of protection IP55 with hinged lockable shutter. Enclosure shall be made of sheet steel of at least 3 mm thickness and shall be suitable for M.S. post mounting. The test stations shall be designed with terminals required for both temporary [TCP] and permanent CP system [PCP] and shall be suitable for total life of permanent CP system.



**TECHNICAL SPECIFICATION  
FOR TCP & PCP**

**Document No.**

11-0330G01-02-10-02-101

**SHEET 33 of 49**

**Rev**

0

- 12.4 The test stations shall be installed with the front of the test station facing the pipeline. The name plate of test stations shall in minimum carry following information.
- Test station number
  - Chainage in km
  - Test station connection scheme type
  - Distance from pipeline in meters
  - Direction of product flow
- 12.5 Terminal blocks and different scheme of wiring as required shall be provided in the test station as per the test station connection scheme sketch.
- 12.6 The location of all the test stations shall be marked with their connection schemes and other relevant information on alignment sheets. A detailed test station schedule shall be prepared.
- 12.7 Computerized Test Stations [CTSUs] to be installed at pre-identified [18] locations along pipeline ROW for Monitoring the CP System adequacy from these locations. Readers three (3) numbers at least to be supplied with ten(10) CTSUs.

### 13 SURGE DIVERTER, GROUNDING CELL AND POLARISATION CELL

- 13.1 At the crossing or parallel run of pipeline and overhead HT line of 66 KV and above, the pipeline shall be grounded through solid state polarisation cell/device. Alternatively, grounding could also be done with galvanic anodes [grounding cells] at the discretion of the owner. The grounding shall be done at regular intervals where transmission line run parallel within 25 m of the pipeline, to ground any surges in the pipeline potential that may appear in case of faults [phase to phase or phase to ground] in overhead transmission line.

Locations along pipeline where continuous induced over-voltage due to HT line etc. is expected &/or observed during commissioning, the pipeline shall be earthed through solid state polarisation cell/device to the HT tower earth system causing the voltage induction to ground or through a separate earthing system. Alternatively the pipeline shall be grounded with galvanic anodes [Grounding cells] at the discretion of the owner.

- 13.2 The solid state polarisation cell/device shall be installed in a vandal proof steel housing by the contractor.
- 13.3 Spark gap surge diverter shall be connected across each insulating joint to protect it from high voltage surges.
- Alternatively, Zinc or Magnesium grounding cell may be provided across insulating joints along ROW where the pipelines on both sides of the insulating joint are Cathodically protected and difference of protection voltage is not more than 0.4 volts.



13.3.1 Surge diverter shall be provided for the protection of insulating joints located at the ends of the pipe line/at terminals & in between. Alternatively owner on his own discretion may permit use of Magnesium (Mg)/Zinc (Zn) galvanic anodes [grounding cells] appropriately sized for protection of insulating joints. Choice between Zn & Mg anodes will depend up on the potential values on either side of the insulating joint locations. These anodes shall be sized for the specified design life of permanent cathodic protection system [PCP].

13.3.2 The total system including cable, cable termination, anodes/surge diverters shall be suitable for the anticipated fault current magnitude at the location of its installation.

13.3.3 Unless otherwise specified the minimum rating of grounding cell, polarisation cell and surge diverter shall be as below:

i. **Grounding Cell**

- Type : 2 or 4 plate type
- Current rating : Suitable to pass more than 10 kA surge

ii. **Polarisation Cell**

- Type : *Solid state device*
- Current rating : The rating shall be based on actual fault current expected at site.

iii. **Surge Diverter**

- Type : Spark gap
- Current 8/20  $\mu$ s) : 100 kA
- Spark over AC voltage : 1 KV
- 50 Hz
- Impulse ( 1.2/50  $\mu$ s) : 2.2 KV

13.4 The grounding cell, surge diverter and the solid state polarisation cell/device system shall be sized for the design life of permanent CP system. The Zinc (Zn) or Magnesium (Mg) anodes meant for pipeline grounding shall also be sized for the life of the permanent CP system and the surge magnitude taking into account the current discharge from the anodes. The grounding system shall have minimum resistance to earth to restrict the pipeline voltage [PSP] as per NACE protection criteria.

**14 CP AT CASED CROSSING**

At all cased crossings the casing shall be coated using 2 pack epoxy, 750 micros thick, both on internal and external surface of the casing. The casing shall be protected additionally by independent [from carrier pipe protection system] sacrificial anode installations. The sacrificial anode installations shall be provided at both ends of casing. The anode installation shall be sized based on the permanent CP design parameters specified for the main pipeline.



<b>Document No.</b>	<b>Rev</b>
11-0330G01-02-10-02-101	0
SHEET 35 of 49	

The carrier pipe inside casing shall be protected by Zn or Mg ribbon anodes well connected to the outer surface of bottom of carrier pipe extending between hour hand positions of 4 and 8 o' clock. The anodes shall be placed at close intervals as per design calculations and sized based on the permanent CP design parameters. Casings upto 20 mts in length may not be provided additional cathodic protection to carrier pipe bottom inside casing. More than 20 mts length casing additional cathodic protection to carrier pipe bottom shall be provide.

The annulus between the casing and the carrier pipe shall be filled with graded sand/ betonite.

The HDD contractor will arrange an agency to check the coating condition of the casing pipe post erection of HDD so that requisite repairs(if required) are done to the damaged coat.

**15 PAINTING**

The sheet steel used for fabrication shall be thoroughly cleaned and degreased to remove mill scale, rust, grease and dirt. Fabricated structures shall be pickled and then rinsed to remove any trace of acid. The under surfaces shall be prepared by applying a coat of phosphate paint and a coat of yellow zinc chromate primer. The under surfaces shall be free from all imperfections before undertaking the finished coat. After preparation of the under surface, spray painting with two coats of final paint shall be done. The finished panel shall be dried in oven in dust free atmosphere. Panel finish shall be free from imperfections like pin holes, orange peels, run off paint etc.

All unpainted steel parts shall be cadmium plated to prevent rust formation.

**16 CABLES**

Cables shall be annealed high conductivity, tinned, stranded copper conductor, PE insulated 650V grade, and PVC sheathed FRLS. The size of the copper conductor shall be 6 sq mm for anode cable from anode to junction box, 10 mm<sup>2</sup> from junction box to test station, 10 mm<sup>2</sup> from test station to pipeline. The size of the conductor shall be 4 mm<sup>2</sup> for potential measurement and 25 mm<sup>2</sup> for bonding, polarization cell / grounding cell and surge diverter connection purpose. The anode cable from anode to junction box shall be unarmored. The length of anode tail cable shall be sufficient enough to reach junction box (buried) in case of temporary CP anode and up to test station in case of permanent CP anodes.

**17 INSTALLATION**

**17.1 CABLE LAYING**

17.2 Cables shall be laid in accordance with approved layout drawings to be prepared by the contractor. No straight through joint shall be permitted in a single run of cable. Cable route shall be carefully measured and cables cut to required length.

	<b>TECHNICAL SPECIFICATION FOR TCP &amp; PCP</b>	Document No.	Rev
		11-0330G01-02-10-02-101	0
		SHEET 36 of 49	

- 17.3 All cables inside station/plant area shall be laid at a depth of 0.75 M. Cables outside station/plant area shall be laid at a depth of 1.5 m . Cables shall be laid in sand under brick cover back filled with normal soil. Out side the station/ plant area the routes shall be marked with polyethylene cable warning mats placed at a depth of 0.9 m from the finished grade.
- 17.4 All underground unarmoured cables forming part of permanent CP system shall run through PE sleeves. Cables along the pipeline shall be carried along the top of the pipe by securely strapping it with adhesive tape or equivalent as required.
- 17.5 RCC or GI pipes of proper size shall be provided for all underground cables for road crossings.
- 17.6 Cables shall be neatly arranged in trenches in such a manner that crisscrossing is avoided and final take off to equipment is facilitated.
- 17.7 Cable root markers shall be installed overground at suitable intervals.
- 17.8 In no case cables shall pass from below underground pipeline. All cables shall be placed above underground pipeline and tightened with tape.

**17.9 CABLE TO PIPE CONNECTIONS**

All cable connections to the pipeline including charged foreign pipeline shall be made using an (owner) approved exothermic process e.g.: Pin Brazing.

The Pin Brazing to have

- |                                     |  |
|-------------------------------------|--|
| 1. extremely low Contact Resistance | ≤ 0.1 Ω.                               |
| 2. Low transition resistance        | 7.5 to 14 μΩ per brazed joint          |
| 3. High mechanical strength         | Binding strength 490 N/mm <sup>2</sup> |
| 4. Shear Strength                   | 245 N/mm <sup>2</sup>                  |
| 5. Brazing Temperature              | 650 <sup>0</sup> C                     |
| 6. Time per Braze                   | 2 Seconds                              |
| 7. Weather Effect                   | Suitable for all weather operation     |
| 8. Life                             | 40 Years + 1                           |

Field Test Cable Connection through Pin Brazing to be field tested for contact resistance & Temperature etc.

**18 CIVIL WORKS**

All civil works associated with the complete cathodic protection work shall be included in the scope of CP contractor. This shall include providing cable trenches, foundation for equipment and all test stations etc.

**19 TESTING AND INSPECTION AT WORKS**

	<p align="center"><b>TECHNICAL SPECIFICATION FOR TCP &amp; PCP</b></p>	Document No.	Rev
		11-0330G01-02-10-02-101	0
		SHEET 37 of 49	

- 19.1 Owner/ Owner's representative shall visit the works during manufacture of various equipment [Anodes, Cables, Junction Boxes, Test Lead Points etc.] to assess the progress of work as well as to ascertain that only quality raw material and fabrication technology is used for the same. All necessary assistance during such inspections shall be provided by the contractor/fabricator to owner's representative.
- 19.2 The minimum testing, inspection requirements for all components/ equipment shall conform to the requirements as defined in the relevant codes and standards. Detailed inspection and testing procedures along with the acceptance criteria, including various stages where hold points, review etc shall be for owners inspection, shall be prepared by CONTRACTOR for Owner's approval.
- 19.3 Test certificates including test records, performance curves etc. shall be furnished. All test certificates shall be endorsed with sufficient information to identify equipment to which the certificate refers to and must carry project title, owner's name and purchase order details etc.
- 19.4 Owner reserves the right to ask for inspection of all or any item under the contract and witness all tests and carry out inspection or authorise his representative to witness test and carry out inspection. CONTRACTOR shall notify the Owner or Owner's representative at least 20 days in advance giving exact details of tests, dates and addresses of locations where the tests would be carried out.

**20 PACKING AND TRANSPORT**

All equipment/ material shall be protected for inland/ marine transport, carriage at site and outdoor storage during transit and at site. All packages shall be clearly, legibly and durably marked with uniform block letters giving the relevant equipment/ material details. Each package shall contain a packing list in a water proof envelope. Copies of the packing list, in triplicate, shall be forwarded to owner prior to despatch. All items of material shall be clearly marked for easy identification against the packing list.

**21 SYSTEM TESTING, COMMISSIONING AND INTERFERENCE MITIGATION**

**21.1 SYSTEM TESTING AT SITE**

- 21.2 Contractor shall furnish the detailed field testing and commissioning procedure for approval. Field tests as per the approved procedures shall be carried out on the equipment/ systems before being put into service. The acceptance of the complete installation shall be contingent upon inspection and field test results being satisfactory.
- 21.3 Before the CP facilities are placed in operation all necessary tests shall be carried out to establish that all equipment, devices, wiring and connection, etc. have been correctly installed, connected and are in good working condition as required for intended operation.
- 21.4 Owner/Owner's representative may witness all the tests. At least one week's notice shall be given before commencing the tests.
- 21.5 All tools, equipment and instruments required for testing shall be provided by C P CONTRACTOR.



<b>Document No.</b>	<b>Rev</b>
11-0330G01-02-10-02-101	0
<b>SHEET 38 of 49</b>	

21.6 Generally following tests shall be carried out and recorded in perform given in subsequent clauses.  
 Checking: Visual inspection, comparison with drawings and specifications.  
 Inspection: Detailed physical inspection & Dimensions measurement  
 Testing: Simulation tests of equipment to determine its operational fitness.

**i. Cables**

- Cable no.
- Voltage grade
- Conductor cross section
- Continuity check
- Voltage test
- Insulation resistance values between core and earth.
- All cables shall be tested by 500 V megger.

**ii. Insulating Joints**

Checking of insulating joint for leakage, before and after energisation of C.P.by means of insulating joint tester. Structure-to-electrolyte potential of both protected and non-protected sides of insulating joint shall be checked before and after energisation of CP system. Grounding cell/Surge diverter shall be connected thereafter.

**iii. Polarisation cell**

- Location/ identification number
- Rating
- Check for continuity
- Check for wiring
- Check for standby current drain with CP energisation (current drain with respect to voltage across the device/cell shall be recorded).

**iv. Grounding Cell**

- Location
- Type (no. of anodes)
- Ratings

**v. Surge diverter**

- Location/ identification number
- Ratings
- Check for healthiness

**vi. Anode ground beds**

- Location/ test station number
- Current Output of each Anode



<b>Document No.</b>	<b>Rev</b>
11-0330G01-02-10-02-101	0
SHEET 39 of 49	

- Current output of the ground bed

## 21.7 COMMISSIONING

21.7.1 Natural pipe to soil potential [P-S-P] shall be measured at each test station [TLP] location prior to connecting anodes to pipeline. The pipe to soil potential observation shall be repeated after connecting the anodes and allowing sufficient time for polarisation. The current output of the anode installation shall also be measured to ensure that it does not exceed the output current capacity of the anodes. In case the anode output current exceeds the rated capacity it shall be controlled by insertion of resistance element in the anode circuit inside test station and the pipe to soil potential shall be rechecked for adequacy of protection. Additional anodes shall be provided where required to achieve desired level of protection [PSP].

Each anode installation shall become individually operational as above.

21.7.2 After connecting all the anode ground beds to pipe line, measurement of pipe to soil potentials shall be taken at each test station [TLP] to ensure adequate conformity to protection criteria.

21.7.3 In case of insufficient protection as per the NACE CP design criteria on any portion of the pipe line, CONTRACTOR shall carry out necessary additions/ modifications to the provided protection in consultation with the ENGINEER so that NACE criteria is met.

## 21.8 INTERFERENCE MITIGATION

Investigation shall be made by an expert agency with prior experience [such as Penspen U.K., PLE GmbH, Van De Velde etc.] for stray current electrolysis of the pipeline. Interference due to high voltage DC lines, electric traction & installed CP System of existing underground utilities and make suitable Recommendations so that recommended D.C. Interference Mitigative measures could be installed.

The C.P. Contractor to carry out Interference due to overhead AC lines and install suitable Mitigative measures for AC Interference.

Measurements including pipe to soil potential [PSP] and pipe line current etc. on the pipeline/ structure being CP protected shall be made to investigate the current discharge [into surrounding soil electrolyte] and collection locations.

In case of fluctuating stray currents investigation shall be made continuously over a period of time and if required simultaneously at different locations to find out the stray current source. For long line measurements, data logges shall preferably be used.

Where foreign pipeline (unprotected or protected by independent CP system) runs in parallel to the pipeline in same trench or very near to the pipeline, and is not bonded to the pipeline then investigation shall be made for current pickup & discharge points on both the pipelines.



TECHNICAL SPECIFICATION  
FOR TCP & PCP

Document No.

11-0330G01-02-10-02-101

SHEET 40 of 49

Rev

0

Mitigation measures shall be provided depending on type of interference. These shall include installation of bond with variable resistor and diodes, installation of galvanic anodes for auxiliary drainage of current, adjustment/ relocation (if possible) of offending interference source, provision of electrical shield etc. depending on the type of interference.

Between an existing pipeline & upcoming pipeline a concrete raft [size to be approved by owner as per OISD] is to be provided as a barrier. The new pipeline will pass below the existing U/G Pipeline.

Bonding with foreign pipeline/ structure as a mitigation measure shall be provided where the owner of the pipeline/ structure has no objection, otherwise alternative mitigation measure shall be provided.

Wherever bonding is provided for mitigation the bonding resistor shall be adjusted for optimum value for minimum / no interference so that no net current flows from one to the other pipeline. Galvanic anodes installed as a mitigation measure shall be sized for the life specified for permanent CP.

**22 SYSTEM MONITORING**

23.1 The temporary CP system provided shall be monitored at all test stations once in a month for healthiness/ adequacy of protection till commissioning of permanent CP or for design life of temporary CP specified, whichever is less. During this period if any deficiency/ interference in protection system is noticed the same shall be rectified / augmented by additional anodes as required. The monitoring report shall be submitted regularly to owner for his review / information.

23.2 P-C-P system after commissioning shall be monitored by the CP contractor for One Year once a month and During this period if any deficiency/ interference in protection system is noticed the same shall be rectified / augmented by additional fixtures as required.

**23 DRAWINGS AND DOCUMENTS**

**23.1 GENERAL**

23.2 Within three weeks from the date of issue of PURCHASER ORDER, CONTRACTOR shall submit four copies of the list of all drawings/ data manuals/procedures for approval, identifying each by a number and descriptive title and giving the schedule date. This list shall be revised and extended, as

23.3 All drawings and documents shall be in English and shall follow metric system. Number of copies of each submission shall be as follows unless otherwise specified.

Submission

No. of copies



**TECHNICAL SPECIFICATION  
FOR TCP & PCP**

<b>Document No.</b>	<b>Rev</b>
11-0330G01-02-10-02-101	0
<b>SHEET 41 of 49</b>	

- a. For review / approval 6 copies + 1 Soft copy
- b. Final/ As built drawings execution/ construction 6 copies + 2 set of[CD]
- c. Drawings issued for execution/ construction 4 copies +[CD]
- d. Operation/ Maintenance manual, vendor data 6 copies +[CD]
- e. Original permissions for Interference detection and Mitigation from other utility owners.
- f. The Original deed for Anode Bed Plot shall be handed over to GAIL.

**23.4 CONTRACT DRAWINGS AND DOCUMENTS**

23.5 As a part of the contract, drawings and documents shall be furnished which shall include but not be limited to the following:

- a. Report on corrosion survey
- b. Basis of system design and design calculations, equipment selection criteria and sizing calculations.
- c. Bill of material, material requisitions, purchase requisitions.
- d. Quality assurance / Quality control procedures

23.6 Detailed construction drawings (including as built status)

- a. Sacrificial anode fabrication drawings
- b. Typical layout drawing for anode ground bed installation and connection.
- c. Equipment layout, cable layout and schedules.
- d. TLP & Junction Box Erection / Installation Details Drawing
- e. Permanent Cu-CuSO<sub>4</sub> reference electrode installation Drawing
- f. Fabrication, installation details of surge diverter, grounding cell and polarisation cell with its enclosure and housing.
- g. Cable- to-pipe joint details for charged and non charged pipelines.
- h. Incorporation of anode beds, polarisation cell, surge diverters, test stations, etc. and other relevant features of CP system-design in Pipeline alignment sheet and other related drawings.
- i. Identification of section of pipeline affected by interference, source of interference and details of interference mitigation arrangements provided. Various measurement data at all relevant test stations with and without mitigation measures provided.
- j. Detailed commissioning report including various measurement data at all test stations etc.
- k. Vendor drawings and catalogues, test certificates.
- l. Operation and maintenance manual.
- m. Miscellaneous
  - Equipment inspection and testing procedure
  - Construction, installation procedures
  - Field testing and commissioning procedures
  - Procedure for monitoring of Cathodic protection after commissioning
  - Quality control procedures.
  - Post Commissioning Testing/Monitoring Periodicity and Methodology

**24 INSTRUMENTS, TOOLS AND SPARES**

24.1 CONTRACTOR shall include a List of all instruments, tools and tackles necessary for proper operation and maintenance [O&M], Monitoring of complete Cathodic protection [TCP] [PCP] systems and associated equipment that are to be deployed at site, such as Corrosion Voltmeter, Multi-combination Meter, CPL Survey Data Logger, DCVG Meter, Holiday Detector, Pipe Locator, Elcometer for Coating thickness measurement, CAT survey, Soil resistivity meter etc. duly calibrated by an Owner Approved agency in last six (6) months.



**TECHNICAL SPECIFICATION  
FOR TCP & PCP**

<b>Document No.</b>	<b>Rev</b>
11-0330G01-02-10-02-101	0
SHEET 42 of 49	

24.2 CONTRACTOR shall provide number of spares and consumables being provided for proper operation and maintenance of part of Cathodic protection [TCP] system to be integrated with permanent CP system [PCP] designed on the basis of permanent CP design parameters and associated equipment, for two (2) years un-interrupted operation of the system.

**25 INFORMATION REQUIRED WITH THE BID**

Bidders are advised in their own interest to provide the following information along with the bid without which the bids are liable for summary rejection.

- A. Work Experience, in detail, Project wise, giving Job content, Year, Status for client etc.
- B. List of Equipments, Tools, Tackles, etc. likely to be deployed at site
  - a. Basis and calculations for preliminary system design for Cathodic protection system [TCP] and [PCP]  
 Viz: Surface Area, Protective Current Required, Anode Weight and size required/provisioned, Anode bed type, Coke Breeze/Backfill required/provisioned, Anode bed Loop Resistance, Remoteness adequacy, Surge Re dressal calculated/provisioned, etc.
  - b. List of formulae with legends to be used for detailed system design calculations.
  - c. Basis of system design, design calculations, equipment selection criteria, sizing calculations along with characteristic curves for various equipment.
  - d. Preliminary bill of material [B O M] for major equipment for [TCP] and [PCP].
  - e. Details of the equipment/ material offered along with technical leaflets / related literatures/ catalogues, make, rating, type test certificates.
  - f. Dimension, weight and general arrangement drawings for each offered equipment.
  - g. List of instruments, tools and tackles offered for maintenance and operation.
  - h. List of recommended maintenance / operation spares.
  - i. Clause-wise deviations, if any, to the specifications along with justifications.
  - j. List & Credentials of Crew to be deployed at site and contractors home office.

**26 APPROVED MAKE OF EQUIPMENT / COMPONENTS FOR C.P. SYSTEM**

26.1 Transformer Rectifier Unit [TRU] AC Input DC Output, & CPPSM

- M/s Canara Electric Controls Mumbai
- M/s CIMCON Software Services Inc.,Ahmedabad

26.2 MMO Anodes

- M/s Titanor Components,Goa
- M/s Eltech, Netherlands
- M/s Oranzio De Nora,USA
- M/s Corpro Technologies, Singapore

26.3 SACRIFICIAL ANODES

- M/s METAL FOUNDERS MUMBAI
- M/S SHAKTI ENTERPRISES AHMEDABAD
- M/s PROTECH ALLOY ANODES KARAIKUDI
- M/s SCIENTIFIC METAL ENGINEERS KARAIKUDI
- M/s CORPEN ANODES
- M/s ELECTRO-PROTECTION SERVICES

26.4 REFERENCE COPPER SULPHATE ELECTRODES

- M/s Harco USA
- M/s MC Miller USA
- M/s BORIN USA
- M/s Electrochemical Devices USA

26.5 JUNCTION BOXES [AJB,CJB,TLP]

**FLAME PROOF**

- 26.5.A M/s EX PROTECTA, MUMBAI
- 26.5.B M/s FCG LIMITED, MUMBAI
- 26.5.C M/s FLEXPRO, NAVSARI
- 26.5.D M/s BALIGA LIGHTING EQUIPMENTS, CHENNAI



**TECHNICAL SPECIFICATION  
FOR TCP & PCP**

<b>Document No.</b>	<b>Rev</b>
11-0330G01-02-10-02-101	0
SHEET 43 of 49	

**NORMAL**

- 26.5.E M/s UNDERGROUND PIPELINE & NDT SERVICES, NOIDA  
 26.5.F M/s CORROSION CONTROL SERVICES, MUMBAI  
 26.5.G M/S CORR-TECH INTERNATIONAL, AHMEDABAD  
 26.6 CABLES  
 26.6.A M/s NETCO CABLES  
 26.6.B M/s FORT GLOSTER CABLES  
 26.6.C M/s CABLE CORPORATION OF INDIA LTD.

**26.7 PIN BRAZING**

- 26.7.A M/s SAFETRACK  
 26.7.B M/s BAC UK

**26.8 SURGE DIVERTORS**

- 26.8.A M/s DEHN GmbH  
 26.8.B M/s CITEL  
 26.8.C M/s MC MILLER  
 26.8.D M/s CONTROL TECHNOLOGY  
 26.8.E M/s DAIRYLAND ELECTRICAL INDUSTRIES  
 26.8.F M/s INTERNATIONAL CORROSION CONTROL Inc.  
 26.8.G M/s RAYCHEM

**26.9 POLARIZATION CELLS / A C DECOUPLING DEVICE**

- 26.9.A M/s KIRK ENGINEERING  
 26.9.B M/s INTERNATIONAL CORROSION CONTROL Inc.  
 26.9.C M/s ELK ENGINEERING ASSOCIATES Inc,  
 26.9.D M/s Rustrol  
 26.9.E M/s Dairy Land Technologies

**26.10 INSULATION MONO BLOCKS**

- 26.10.A M/s BASCO  
 26.10.B M/s ALFA  
 26.10.C M/s R M A  
 26.10.D M/s NUOVAGIUNGAS  
 26.10.E M/s ZUNT  
 26.10.F M/s PHOCENNE  
 26.10.G M/s PIPELINE ENGINEERING & SUPPLY CO.  
 26.10.H M/s TUBE TURN TECHNOLOGIES  
 26.10.I M/s KEROTEST MFG.  
 26.10.J M/s INTERNATIONAL CORROSION CONTROL Inc.  
 26.10.K M/s PIPELINE SEAL & INSULATORS Inc.,

**26.11 E R PROBES**

- 26.11.A M/s ROHRBACK COSACO SYSTEMS,INC.  
 26.11.B M/s METAL SAMPLES  
 26.11.C M/s CORRTEST

**26.12 THIRD PARTY INSPECTION AGENCIES**

- 26.12.A M/s BVIS  
 26.12.B M/s EIL  
 26.12.C M/s PDIL  
 26.12.D M/s DNV

**26.13. Execution Agencies for [TCP] & [PCP] System**

- 26.13.A M/s Corrttech International ,Ahmedabad  
 26.13.B M/s Raychem RPG,Mumbai  
 26.13.C M/s Corrosion Control Services, Mumbai



**TECHNICAL SPECIFICATION  
 FOR TCP & PCP**

Document No.

Rev

11-0330G01-02-10-02-101

0

SHEET 44 of 49

26.13.D M/s S S Electricals,Mumbai  
26.13.E M/s UGPI NDTs, Nouda



**TECHNICAL SPECIFICATION  
FOR TCP & PCP**

Document No.	Rev
11-0330G01-02-10-02-101	0
SHEET 45 of 49	

## APPENDIX A

### COMPUTERISED TEST STATION UNITS (CTSUs) FOR CATHODIC PROTECTION PERFORMANCE MONITORING

Each CTSU (Computerised Test Station Unit) is a Microprocessor based low CMOS circuitry with built in RTC, installed near a Computerised Test Station to acquire and store the complete CP System performance data available for each Test station. CTSUs are typically designed for outdoor applications and are NEMA4 protected.

Once stored, the data can be downloaded as under:

- a) By a remote computer by telephone, cellular phone or radio link/OFC.
- b) By portable handheld data reader using local communication port.

Key features of the CTSU are as under:

1.	Recording Rate	To be configured from 1 reading per second to 1 reading per 365 days.
2.	Battery backup	Lithium battery back up option allowing CTSU ECU to retain data for 10 years on a single charge.
3.	Timing	Status input sampling time 10m sec to 2.5 m-sec.
4.	Power requirement	The CTSU to be powered by 24 $\pm$ 15% Volts DC
5.	The CTSU shall be able to read and record.	PSP and current data of pipeline & foreign pipeline/pipelines upto 10,000 sets to be stored till downloaded
6.	Inputs available	Minimum 10 nos. [5 inputs for PSP & 5 inputs for current.]
7.	Protection against	Voltage/current surges expected along the pipeline & foreign structure.
8.	Test Station Reader (TSR)	Portable type suitable for field transport & handing. Unit enclosure is weather proof, IP55.
9.	Input battery for TSR	Internal rechargeable battery provided.

**To be installed at pre-identified locations**



TECHNICAL SPECIFICATION  
FOR TCP & PCP

Document No.

11-0330G01-02-10-02-101

SHEET 46 of 49

Rev

0

## APPENDIX-B

### POST C.P. COMMISSIONING SURVEYS

#### 1. COATING CONDUCTANCE SURVEYS

For evaluation of the electrical strength of the coating, post commissioning of the C.P. System, after one (1) Month, Coating Conductance surveys to be conducted, to serve as Reference for future comparison. Although same coating specifications are used throughout the length of the pipeline, effective electrical strength thereby it's ability to resist flow of current would reasonably vary on account of terrain, construction defects, soil resistivity along the Pipeline length.

For conducting coating conductance surveys, Potential ( $\Delta V$ ) & ( $\Delta I$ ) Current are to be measured at two consecutive "B" type Test Lead Points [TLP], w.r.t remote earth using  $CuCuSO_4$  reference electrode, alternatively with current interrupter "On" & "Off" at each measurement point.

The difference of the two  $\Delta I$  will be the C.P. Current being collected by this section of the pipeline.

The difference of the two  $\Delta V$  will be the average change in pipeline potential within the test section owing the current received from C.P. System.

The above procedure to be repeated for all "B" type TLP for evaluating coating conductance value for different sections along the pipeline. All the Data obtained is to be handed over to the owner & will form part of final Technical Documentation.

Before commencement of site surveys the survey procedure shall be got duly approved from the Owner.

#### 2. DCVG SURVEY

Post commissioning of the C.P. System, after 30 days of Line polarization, CPL Survey will be conducted for evaluation of coating condition to serve as future Benchmark for comparative evaluation.

Any finding of coating defect in particular, where coating defects and holidays are high, have to be further established through a separate **DCVG** survey for the defective stretch delineated as above from CPL survey findings.

Prior to commencement of **DCVG** survey, the survey procedure to be got approved from the Owner.

Only Good & Proven survey equipment and trained, experienced manpower to be used.

All survey Data to be submitted to Owner as part of Technical Documentation.

#### 3. COMPUTERIZED POTENTIAL LOGGING [CPL] SURVEY

Post commissioning of the C.P. System, after 30 days of Line polarization, a Computerized Potential Logging [CPL] survey will be conducted, as per procedure, already got approved by the Owner. The "On"/"Off" Potential survey. For the survey, Data Logger of repute & Current interrupter [if not available in the TRU] will be used by experienced and trained manpower. All the survey data and findings of under-protected, over-protected zones, short etc. shall be handed over to the owner as part of final technical Documentation. Suitable remediation measures to be recommended for achieving adequacy of protection throughout the pipeline length. This CPL survey Data will serve as base Data for future comparative evaluations of the Protective system adequacy.

#### 3. A.C. /D.C. INTERFERENCE DETECTION & MITIGATION

Post commissioning of the C.P. System, after 30 days of Line polarization, an AC / DC Interference survey to detect presence (or absence) of induced AC Voltages [which in certain circumstances may be fatal] on the underground pipeline that run parallel to AC transmission systems [having voltages greater than or equal to  $\geq 11KV$ ] shall be carried out. Measurement of P-S-P shall be taken at every TLP of the pipeline that run parallel to overhead AC transmission lines and are within 20 M of



TECHNICAL SPECIFICATION  
FOR TCP & PCP

Document No.

11-0330G01-02-10-02-101

SHEET 47 of 49

Rev

0

transmission line alignment. On detection of AC induced Hazardous voltages suitable Mitigative measures such as grounding of the pipeline with Zn / Mg Grounding cell, installation of Polarization cell etc. shall be resorted to dissipate Ac induced hazardous voltages to ground in controlled manner. Type "A" TLP shall be provided at these locations having AC induced Hazardous voltages on the pipeline.

DC Interference Detection from existing CP system in close vicinity of [MM PL] ROW and any other DC source such as electric traction, switching yard, welding shop etc. Appropriate measures for mitigation to be recommended for installation by CP contractor.

Prior to site survey commencement, the Approval for survey procedure, from the Owner, shall be taken.

Σ Σ Σ



**TECHNICAL SPECIFICATION  
FOR TCP & PCP**

<b>Document No.</b>	<b>Rev</b>
11-0330G01-02-10-02-101	0
SHEET 48 of 49	

## APPENDIX-C

### INTERFACING WITH SCADA

Cathodic Protection (CP) panel shall be properly interfaced with RTU through RS 485 serial link for various signals like pipeline under protection, pipeline overprotection, all reference fail, unit working in auto mode, unit working in AVCC mode, unit working in local / remote mode, setting of DC O/P voltage, setting of DC output current, setting of Pipe soil potential (PSP), setting of auto / AVCC mode. CONTRACTOR to note that SCADA vendor shall provide RS 485 serial link at the RTUs for interfacing with CP system. Hence, CONTRACTOR shall also provide RS 485 serial link (Modbus ASCII & Modbus RTU protocol which shall be user selectable). The digital and analog data shall be made available to RTU (SCADA) and it shall be mapped in the contiguous registers so that data can be fetched / written in minimum transactions.

CONTRACTOR shall furnish all details like pin configuration and signal wise MODBUS address mapping list etc. for smooth interfacing of this communication link with RTU (SCADA).

CONTRACTOR shall also furnish the details of implemented MODBUS protocol like function codes for read and write, CRC implementation, BCC implementation, register addressing methods / mapping etc. during detail engineering for serial interfaces with RTU (SCADA).

The following hardwired signals shall be taken from CP system to SCADA system (however hardwired cables shall be routed through PLC cabinet):

- PSP Value
- Impressed Voltage
- Impressed Current
- Start / Stop of Current Interrupter



1

2

3

4

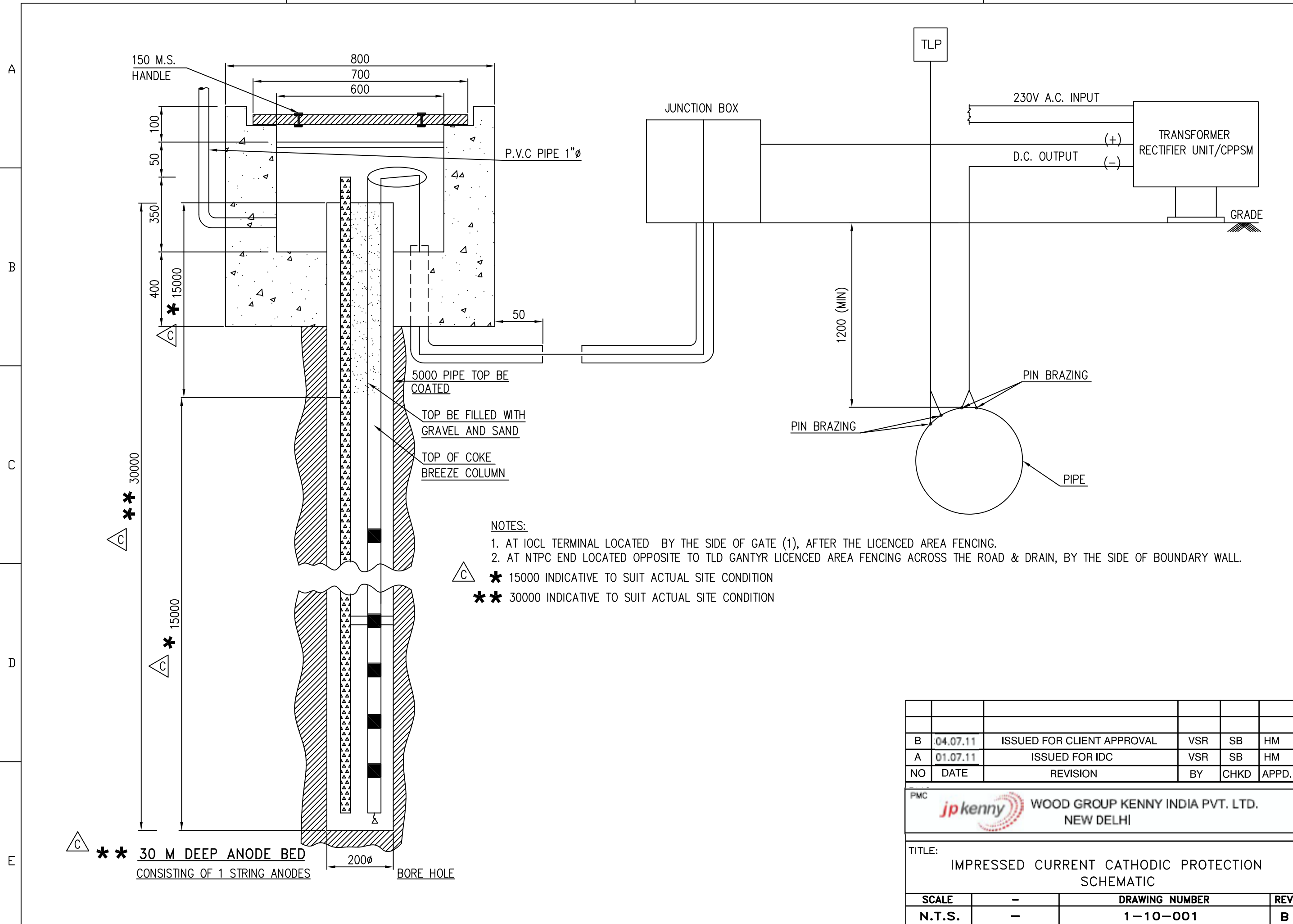

**NOTES:**

- 1. AT IOCL TERMINAL LOCATED BY THE SIDE OF GATE (1), AFTER THE LICENCED AREA FENCING.
- 2. AT NTPC END LOCATED OPPOSITE TO TLD GANTYR LICENCED AREA FENCING ACROSS THE ROAD & DRAIN, BY THE SIDE OF BOUNDARY WALL.
- △ 15000 INDICATIVE TO SUIT ACTUAL SITE CONDITION
- \*\* 30000 INDICATIVE TO SUIT ACTUAL SITE CONDITION

NO	DATE	REVISION	BY	CHKD	APPD.
B	04.07.11	ISSUED FOR CLIENT APPROVAL	VSR	SB	HM
A	01.07.11	ISSUED FOR IDC	VSR	SB	HM

PMC  
**jp kenny** WOOD GROUP KENNY INDIA PVT. LTD.  
 NEW DELHI

TITLE:  
**IMPRESSED CURRENT CATHODIC PROTECTION SCHEMATIC**

SCALE	-	DRAWING NUMBER	REV
N.T.S.	-	1-10-001	B

1

2

3

4

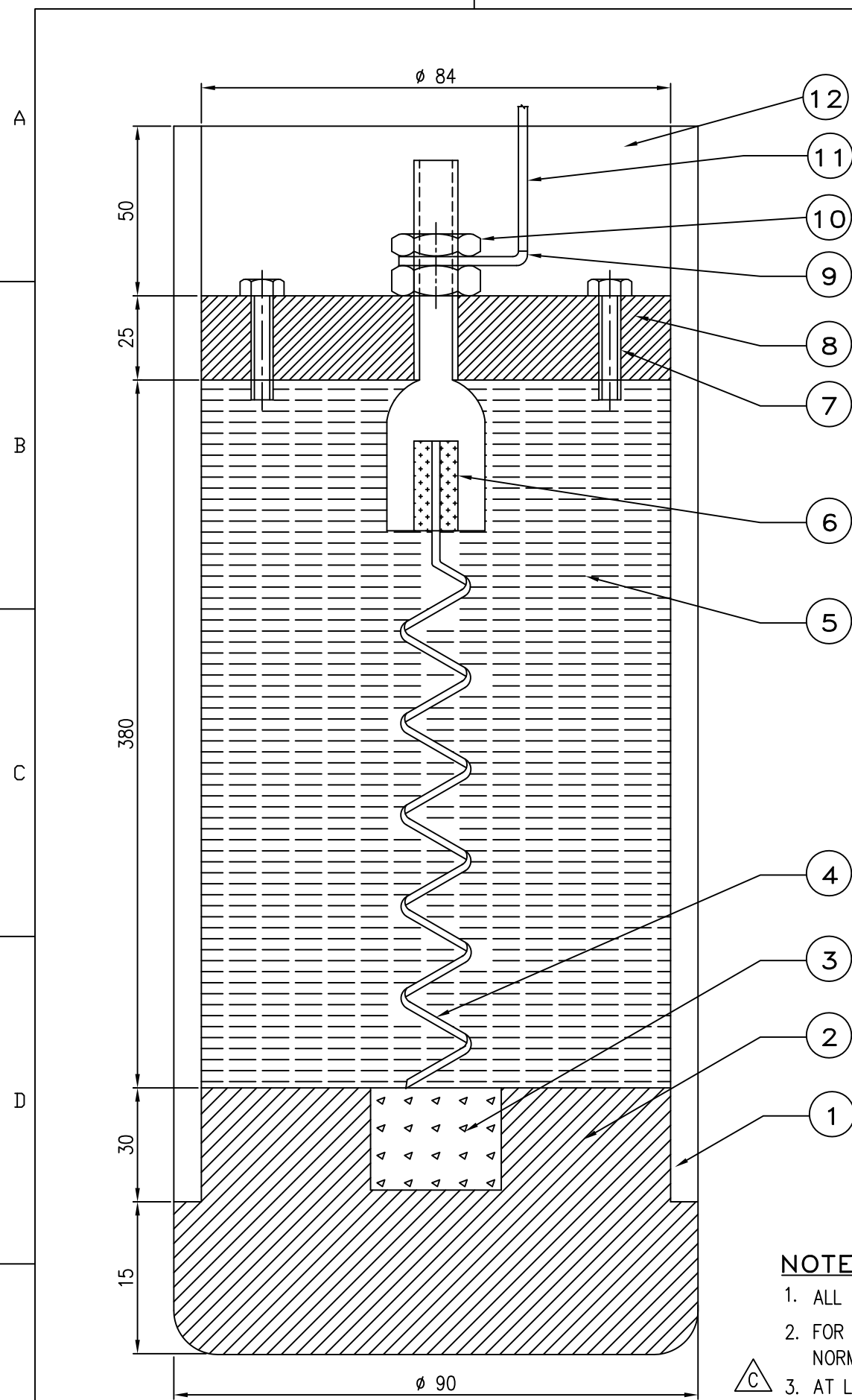

CARRIER PIPE

ARRANGEMENT OF TWO REFERENCE  
ELECTRODES ON PIPE LINE TYPICAL  
INSTALLATION DETAILS

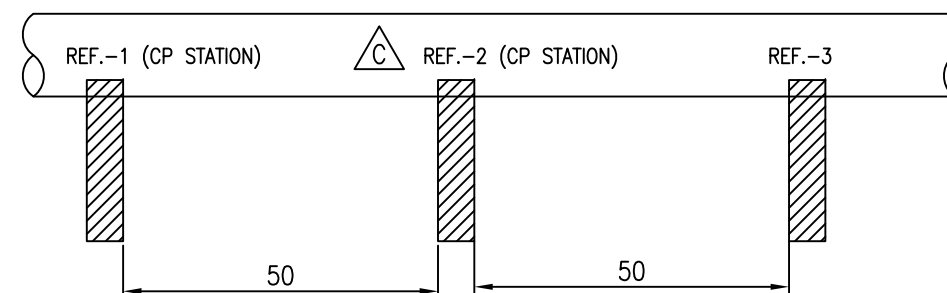

**NOTES :-**

1. ALL DIMENSIONS ARE IN MM UNLESS OTHERWISE SPECIFIED.
2. FOR CABLE TO REFERENCE CELL CONNECTION FOLLOW THE NORMAL CABLE CONNECTION PROCEDURE.
3. AT LEAST 2 NOS REF. ELECTRODE SHOULD BE INSIDE THE C.P. STATION.

**BILL OF MATERIAL**

SL NO.	DESCRIPTION	QTY.
1.	P.V.C PIPE 3 MM THICK	1 NO.
2.	SAG WOOD PLUG	1 NO.
3.	CUSO4 CRYSTALS	AS REQD.
4.	ELECTROLYTIC COPPER SPIRAL 8 MM $\phi$	1 NO.
5.	CUSO4 SATURATED SOLUTION	AS REQD.
6.	BRAZED COPPER JOINT	1 NO.
7.	WATER FILLING BOLTED HOLES $\phi$ 8 MM	2 NOS.
8.	HYLAM BUSH	1 NO.
9.	COPPER LUG	1 NO.
10.	BOLTED CABLE CONNECTION	1 NO.
11.	CONNECTION CABLE 10 MM <sup>2</sup>	AS REQD.
12.	EPOXY FOR SEALING	AS REQD.

NO	DATE	REVISION	BY	CHKD	APPD.
B	04.07.11	ISSUED FOR CLIENT APPROVAL	VSR	SB	HM
A	01.07.11	ISSUED FOR IDC	VSR	SB	HM

PMC  
 WOOD GROUP KENNY INDIA PVT. LTD.  
 NEW DELHI

TITLE:  
 FABRICATION AND INSTALLATION DETAILS OF  
 ELECTRODES PIPELINE

SCALE	-	DRAWING NUMBER	REV
N.T.S.	-	1-10-002	B

1

2

3

4

A

B

C

D

E

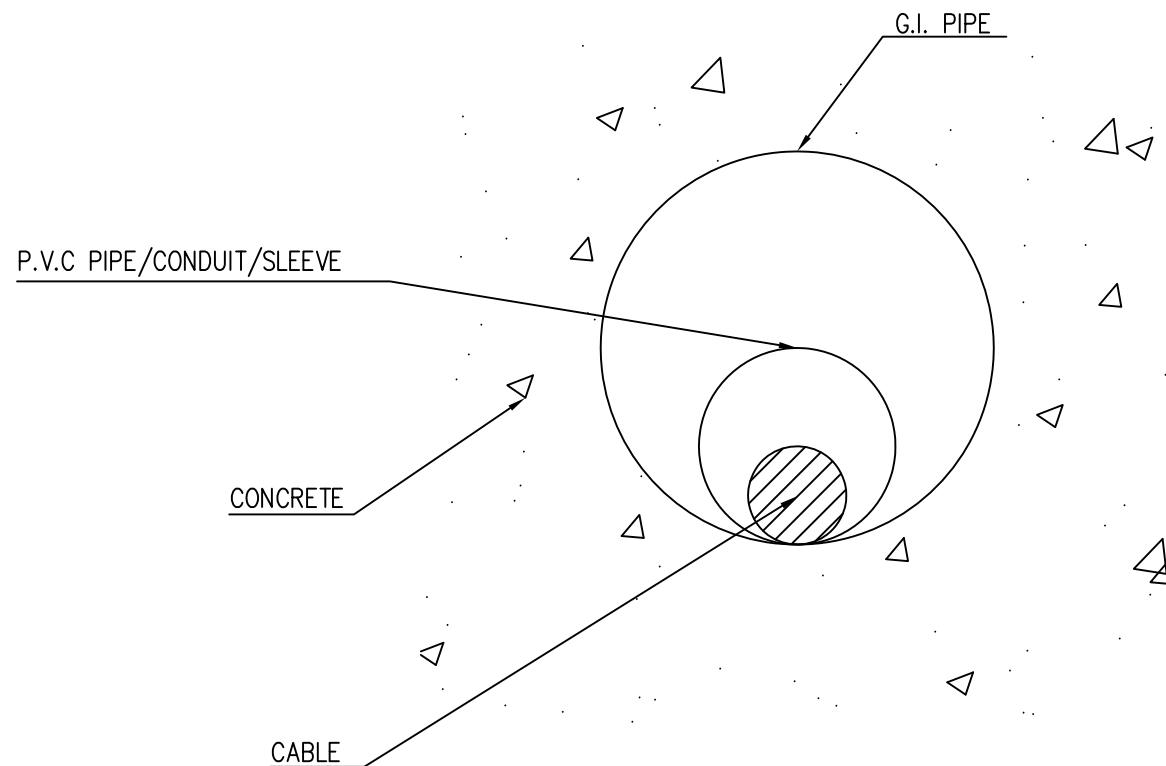

**SECTION VIEW OF CABLE LAYOUT IN CONCRETE**

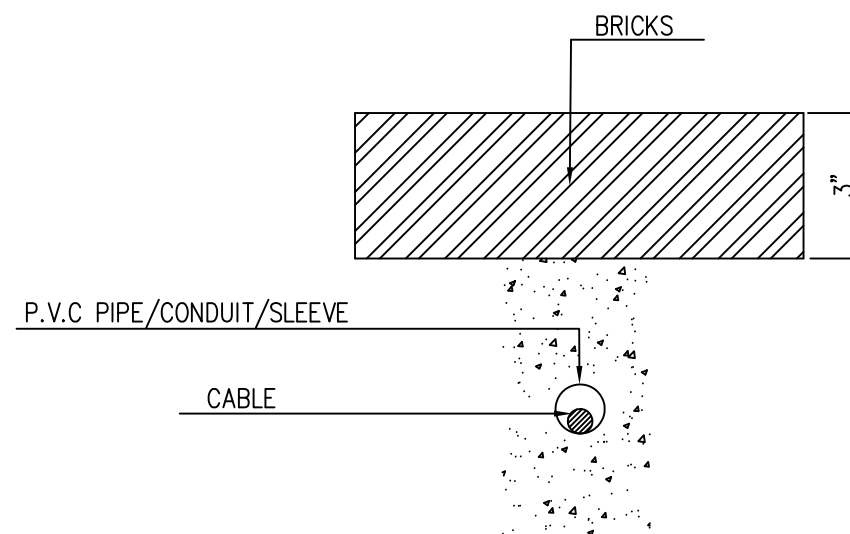

**ENLARGED DETAIL-X FOR NORMAL LAYING IN EARTH**

**NOTES :-**

1. ALL DIMENSIONS ARE IN MM UNLESS OTHERWISE SPECIFIED.
2. ALL UNDERGROUND CABLE SHALL BE LAID IN BRICK COVERING WITH SAND BACKFILL.
3. FOR MORE THAN ONE CABLE IN THE SAME CABLE TRENCH CABLE SHALL BE LAID SIDE BY SIDE IN SEPARATE BRICK COVERING.
4. AT BOTH ENDS OF CABLE TERMINATION A LOOP OF ONE METER (MINIMUM) SHALL BE KEPT AS SPARE.
5. WHEREVER TERMINATION IN BETWEEN IS REQUIRED T-JOINTS OR ELBOWS SHALL BE PROVIDED.
6. AT ROAD/NALA CROSSINGS, G.I. PIPE CONDUIT SHALL BE USED.

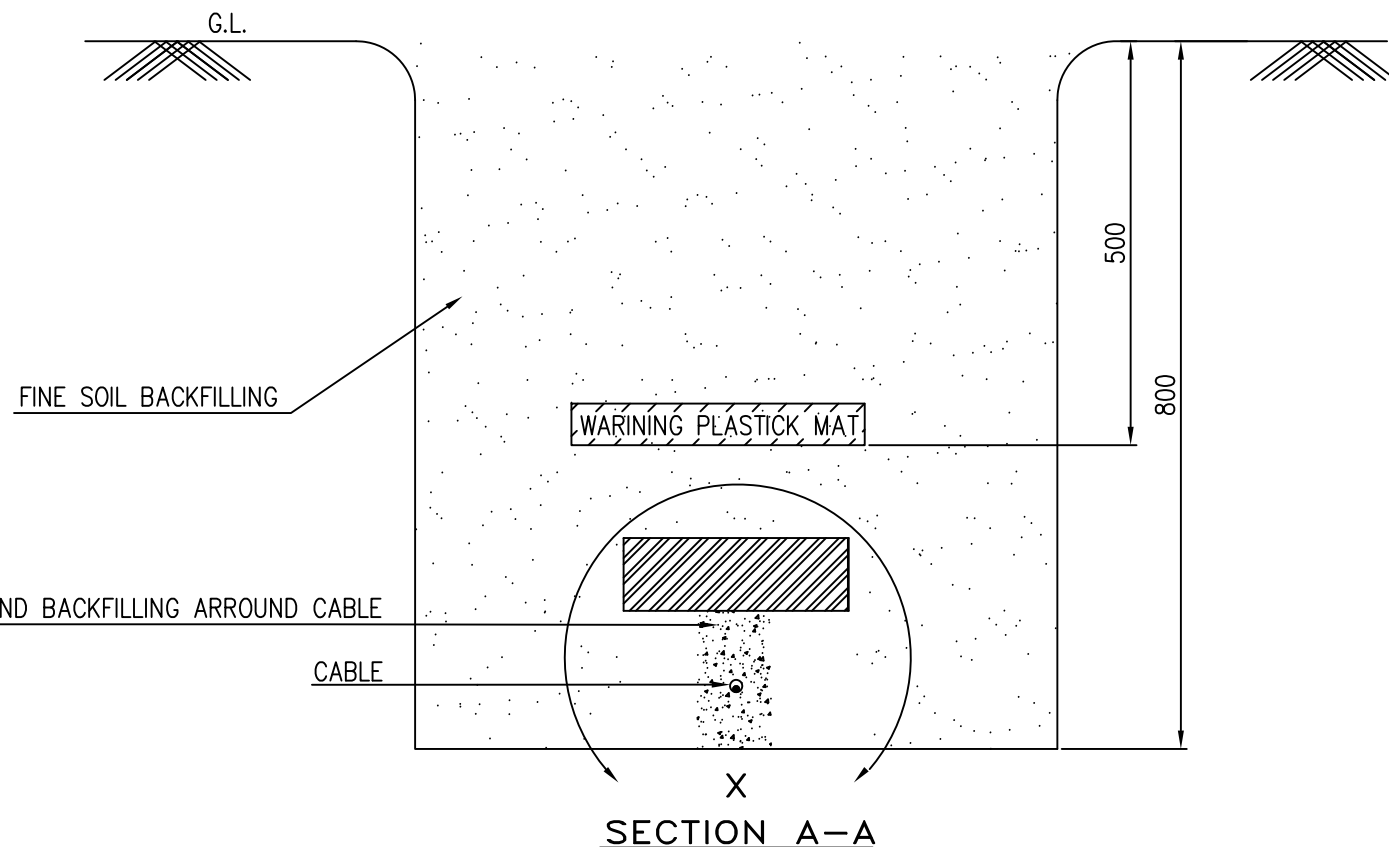

NO	DATE	REVISION	BY	CHKD	APPD.
B	04.07.11	ISSUED FOR CLIENT APPROVAL	VSR	SB	HM
A	01.07.11	ISSUED FOR IDC	VSR	SB	HM

PMC **jp kenny** WOOD GROUP KENNY INDIA PVT. LTD. NEW DELHI

TITLE: FABRICATION AND INSTALLATION DETAILS OF CABLE LAYING (TYPICAL)

SCALE	-	DRAWING NUMBER	REV
N.T.S.	-	1-10-003	B

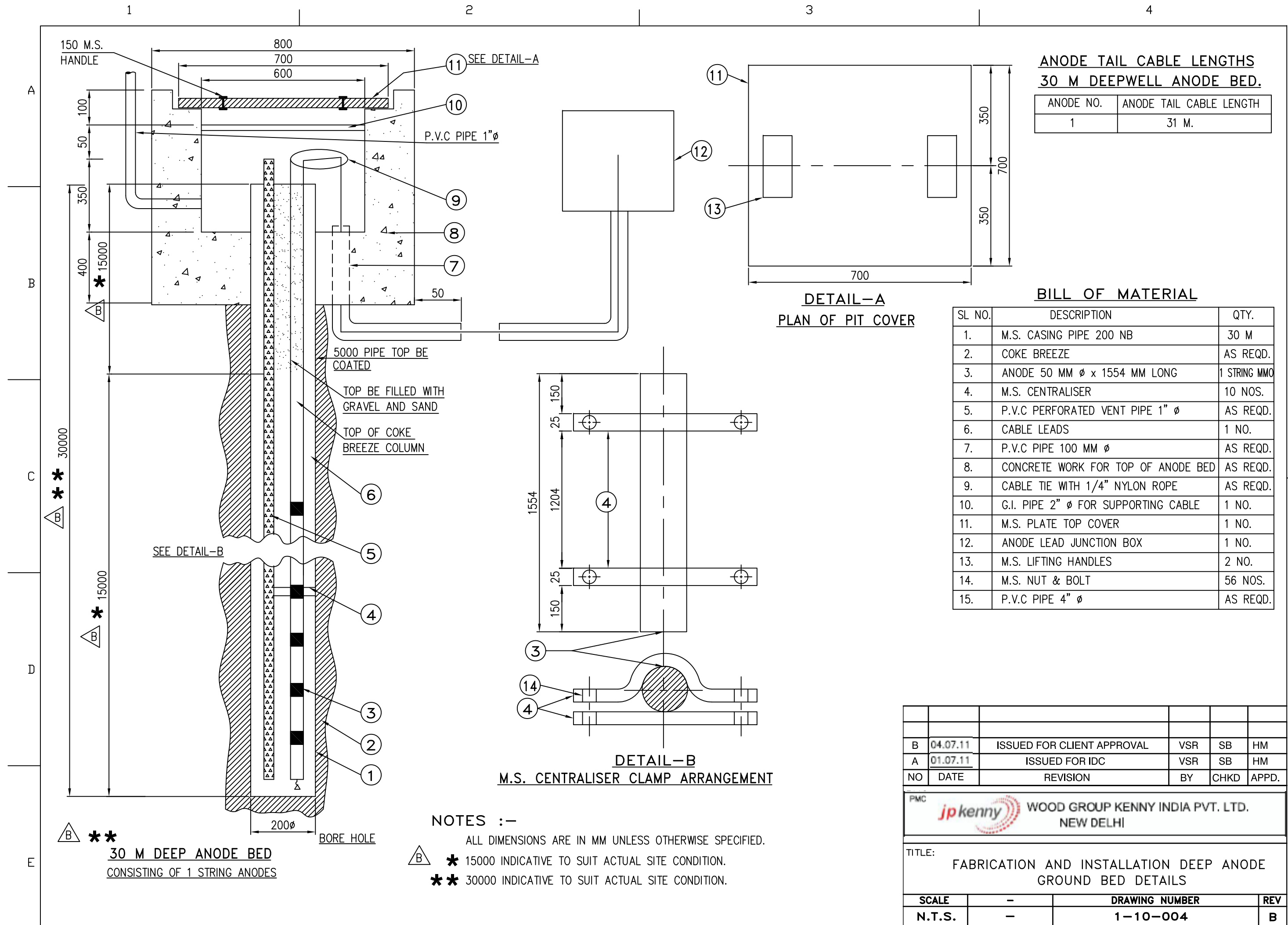

**ANODE TAIL CABLE LENGTHS  
30 M DEEPWELL ANODE BED.**

ANODE NO.	ANODE TAIL CABLE LENGTH
1	31 M.

**BILL OF MATERIAL**

SL NO.	DESCRIPTION	QTY.
1.	M.S. CASING PIPE 200 NB	30 M
2.	COKE BREEZE	AS REQD.
3.	ANODE 50 MM $\phi$ x 1554 MM LONG	1 STRING MMO
4.	M.S. CENTRALISER	10 NOS.
5.	P.V.C PERFORATED VENT PIPE 1" $\phi$	AS REQD.
6.	CABLE LEADS	1 NO.
7.	P.V.C PIPE 100 MM $\phi$	AS REQD.
8.	CONCRETE WORK FOR TOP OF ANODE BED	AS REQD.
9.	CABLE TIE WITH 1/4" NYLON ROPE	AS REQD.
10.	G.I. PIPE 2" $\phi$ FOR SUPPORTING CABLE	1 NO.
11.	M.S. PLATE TOP COVER	1 NO.
12.	ANODE LEAD JUNCTION BOX	1 NO.
13.	M.S. LIFTING HANDLES	2 NO.
14.	M.S. NUT & BOLT	56 NOS.
15.	P.V.C PIPE 4" $\phi$	AS REQD.

**DETAIL-B  
M.S. CENTRALISER CLAMP ARRANGEMENT**

**NOTES :-**

- ALL DIMENSIONS ARE IN MM UNLESS OTHERWISE SPECIFIED.
- $\triangle$  \* 15000 INDICATIVE TO SUIT ACTUAL SITE CONDITION.
- \*\* 30000 INDICATIVE TO SUIT ACTUAL SITE CONDITION.

**30 M DEEP ANODE BED  
CONSISTING OF 1 STRING ANODES**

NO	DATE	REVISION	BY	CHKD	APPD.
B	04.07.11	ISSUED FOR CLIENT APPROVAL	VSR	SB	HM
A	01.07.11	ISSUED FOR IDC	VSR	SB	HM

PMC **jpkenney** WOOD GROUP KENNY INDIA PVT. LTD.  
NEW DELHI

TITLE:  
**FABRICATION AND INSTALLATION DEEP ANODE  
GROUND BED DETAILS**

SCALE	-	DRAWING NUMBER	REV
N.T.S.	-	1-10-004	B

1

2

3

4

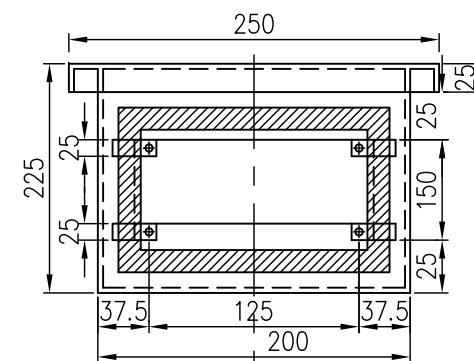
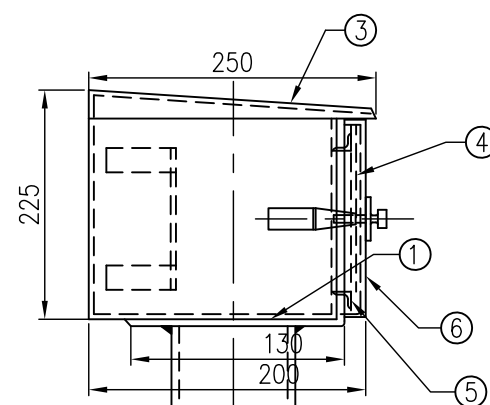
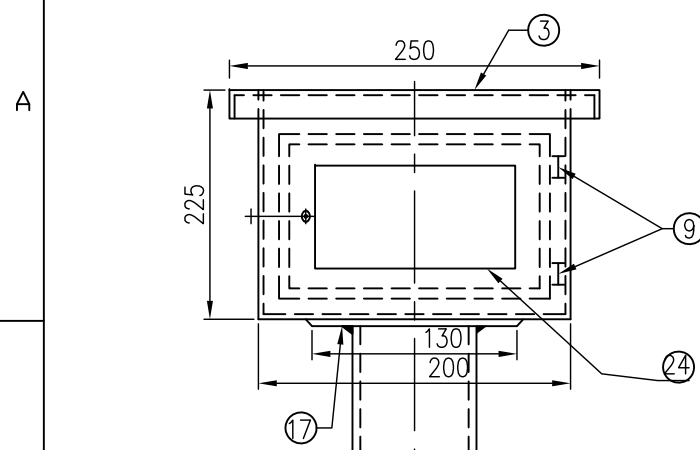

FRONT VIEW DOOR REMOVED

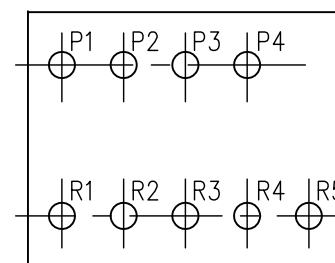

TERMINAL PLATE DETAIL

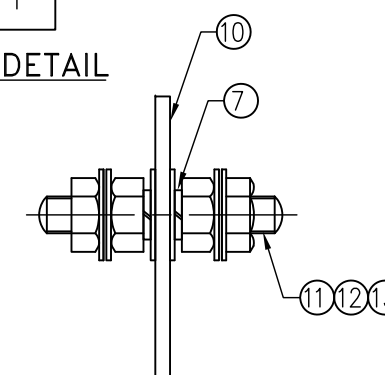

SIDE ELEVATION

## BILL OF MATERIAL

SL NO.	DESCRIPTION	QTY.
1.	BOTTOM PLATE, 5TKx194 MS PLATE	001
2.	REAR & SIDE, 2.67x217x704 MS	001
3.	TOP, 2.67x250x300 MS	001
4.	FRONT TOP 2.67 x190x81 MS	001
5.	FRONT BOTTOM, 2.67x190x81 MS	001
6.	SHUTTER 2.67x234x234 MS	001
7.	SPRING WASHER SC. B.6	066
8.	CASTLE LOCK WITH MASTER KEY (3NOS. KEY)	001
9.	HINGE FOR SHUTTER	002
10.	TERMINAL PLATE, 8x150x150 PHENOLIGE LAM SHT.	001
11.	BRASS STUD M6x50LG (FOR TERMINALS)	001
12.	BRASS NUT M6	044
13.	BRASS WASHER	044
14.	MS. ANGLE 5TKx50x50x30	004
15.	STEEL SCREW, M6x16	004
16.	LATCH FOR SHUTTER	001
17.	MS COUPLING PLATE, 5TKx130x130 MS PLATE	001
18.	MS PIPE, 100 NB x 5.4 TKx 1275MM	001
19.	NEOPRENE RUBBER GASKET 6 TK.	001 SET
20.	FOUNDATION PLATE 6TKx400x400 AA 10108	002
21.	RUBBER BUSH	001
22.	FOUNDATION BOLT M14x125 LG WITH SPRING WASHER AND NUT	001
23.	STIFFENER PLATE 6TKx100x100	001
24.	NAME PLATE ANNODISED AL 0.9x120x160	001

B

C

D

E

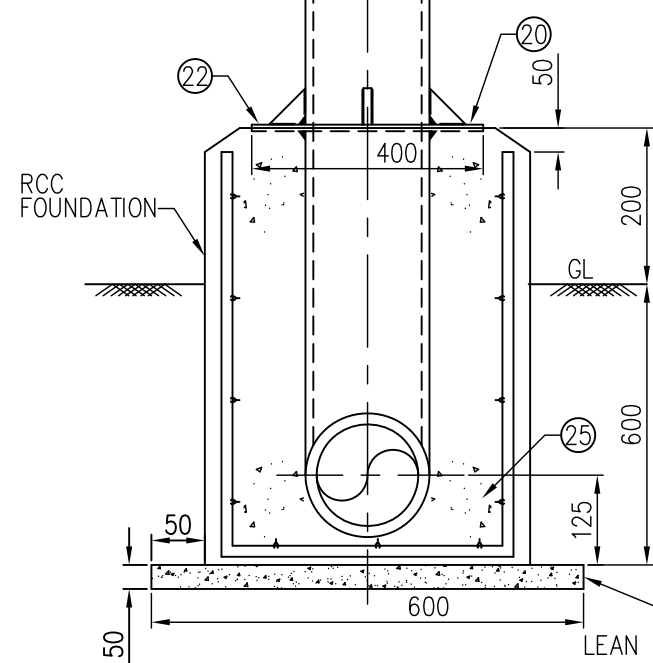

FRONT ELEVATION

LEAN CONCRETE 1:4:8

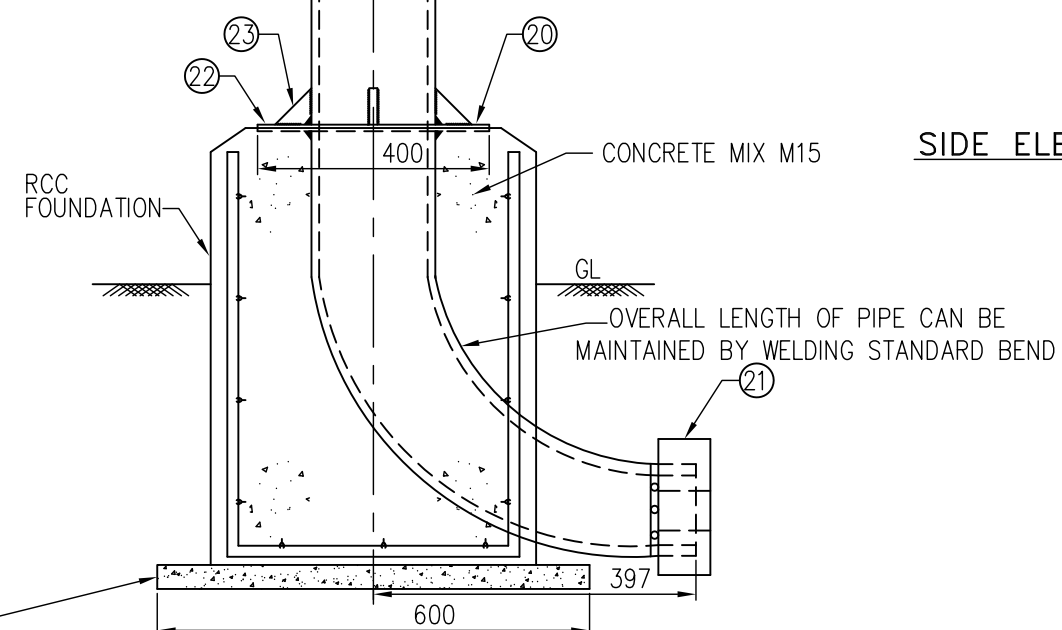

SIDE ELEVATION

CONCRETE MIX M15

OVERALL LENGTH OF PIPE CAN BE MAINTAINED BY WELDING STANDARD BEND

21

NO	DATE	REVISION	BY	CHKD	APPD.
B	04.07.11	ISSUED FOR CLIENT APPROVAL	VSR	SB	HM
A	01.07.11	ISSUED FOR IDC	VSR	SB	HM



TITLE:  
TEST LEAD POINTS & JUNCTION BOX WITH FOUNDATION DETAILS

SCALE	-	DRAWING NUMBER	REV
N.T.S.	-	1-10-005	B

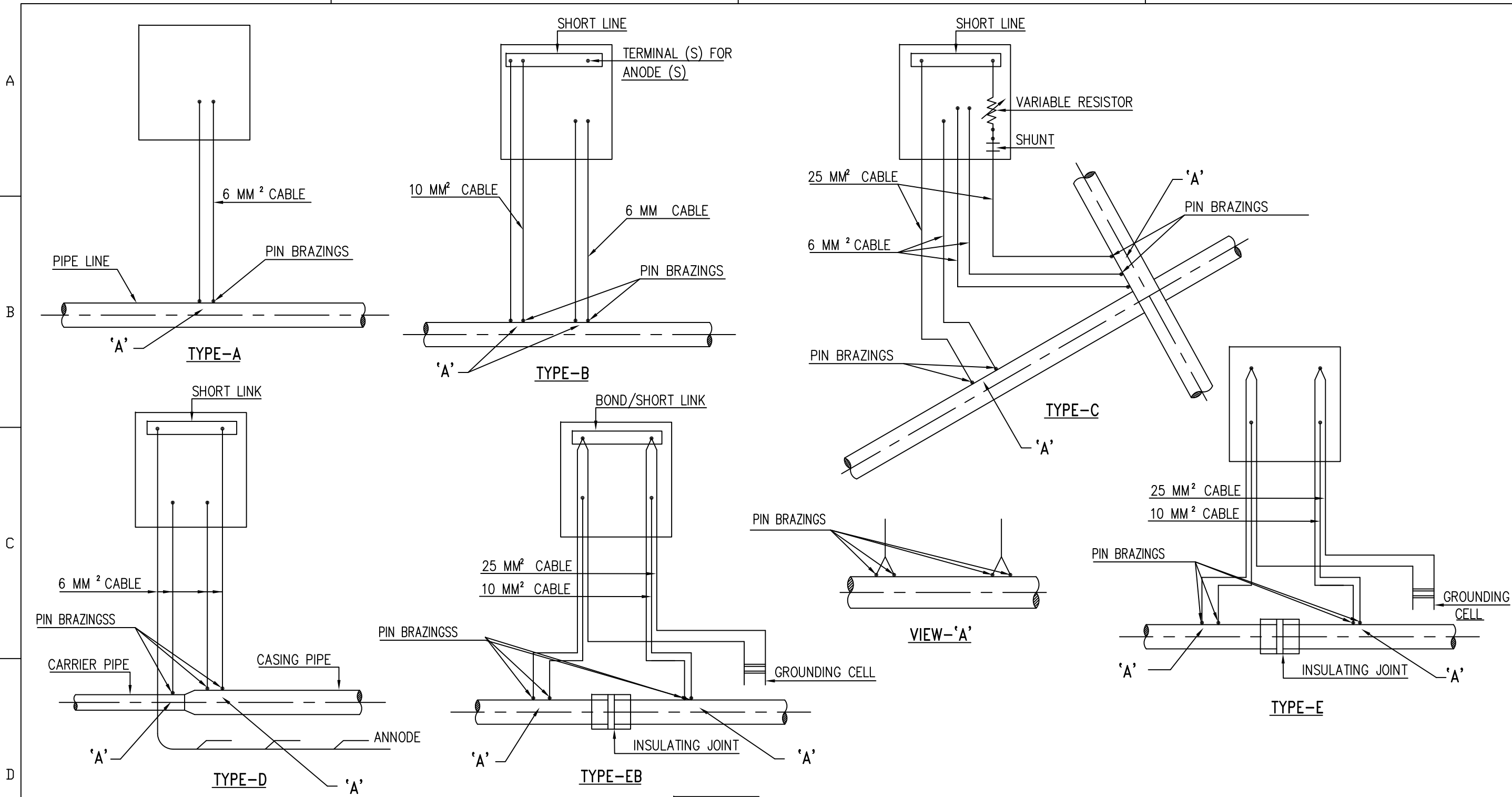

- NOTES :-**
1. THE CONNECTION SCHEMES ARE TYPICAL
  2. REQUIRED CONNECTION SCHEME SHALL BE PROVIDED ON THE TERMINAL PLATE OF TEST LEAD POINT.

**DETAILS OF CONNECTION SCHEME**

TYPE A : PSP MONITORING ONLY.  
 TYPE A1 : LINE CURRENT MEASUREMENT.  
 TYPE B : ANODE TO PIPE CONNECTION.  
 TYPE C : PIPE LINE CROSSING.  
 TYPE D : CASED CROSSING.  
 TYPE E : GROUNDING CELL UNBONDED.  
 TYPE EB : GROUNDING CELL BONDED.

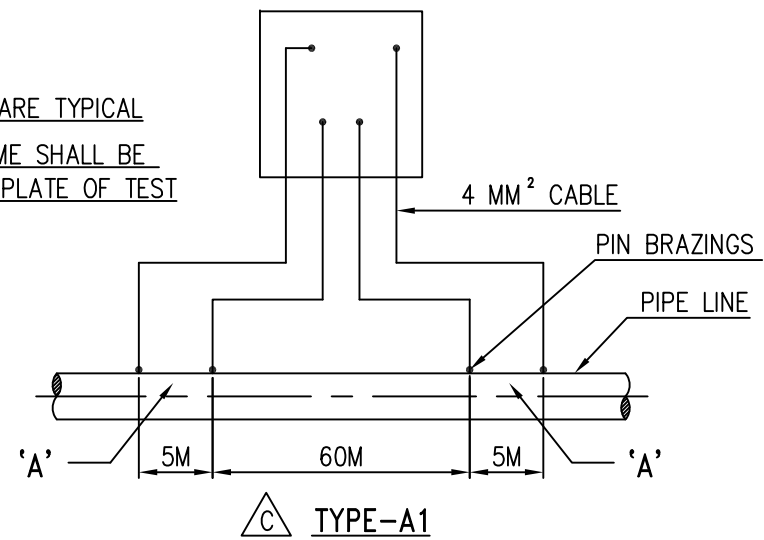

B	04.07.11	ISSUED FOR CLIENT APPROVAL	VSR	SB	HM
A	01.07.11	ISSUED FOR IDC	VSR	SB	HM
NO	DATE	REVISION	BY	CHKD	APPD.

PMC **jpkenney** WOOD GROUP KENNY INDIA PVT. LTD. NEW DELHI

TITLE: TEST STATION CONNECTION SCHEME (TYPICAL) DETAILS

SCALE	-	DRAWING NUMBER	REV
N.T.S.	-	1-10-006	B

1

2

3

4

Test Lead Points (TLP) at every 1.5 Km.

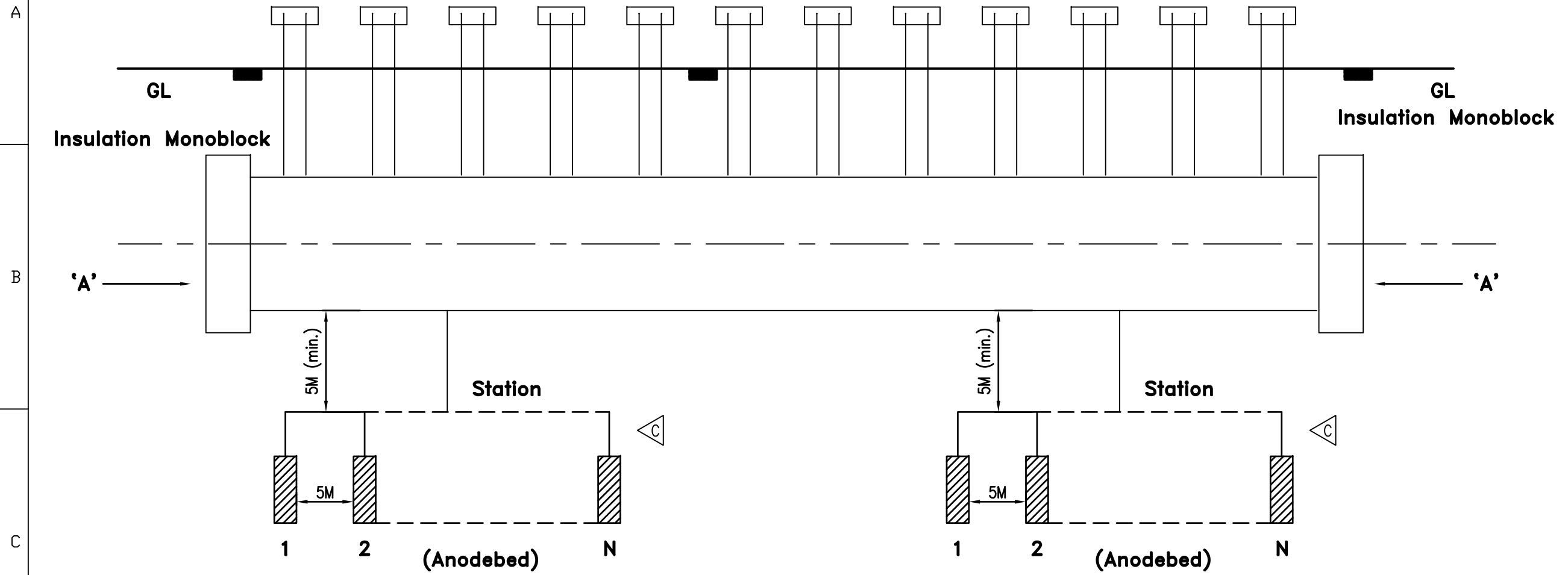

Pre-packed Mg Anodes.

NOTE:  
Mg ANODES TO BE BUNCHED TOGETHER IN ANODEBEDS AT LOCATIONS MOST SUITED AS PER ATTENUATION CALCULATIONS.

TLP Connection Details

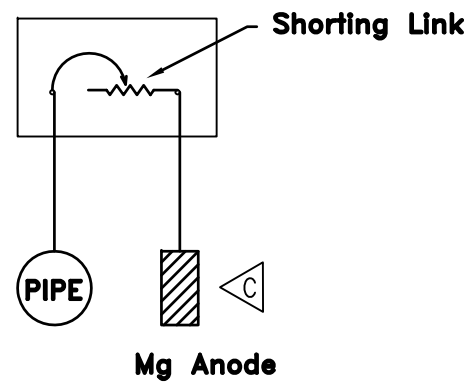

Insulation Monoblock

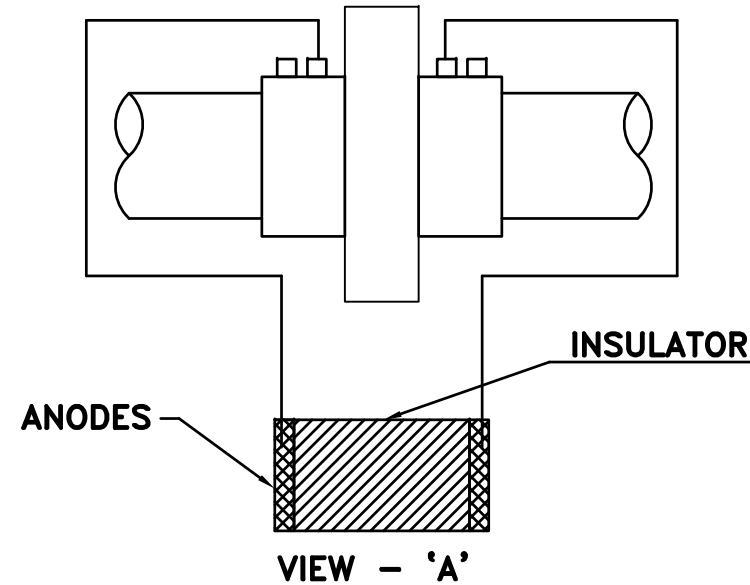

B	04.07.11	ISSUED FOR CLIENT APPROVAL	VSR	SB	HM
A	01.07.11	ISSUED FOR IDC	VSR	SB	HM
NO	DATE	REVISION	BY	CHKD	APPD.

PMC  
 WOOD GROUP KENNY INDIA PVT. LTD.  
 NEW DELHI

TITLE:  
TEMPORARY CATHODIC PROTECTION SCHEMATIC

SCALE	-	DRAWING NUMBER	REV
N.T.S.	-	1-10-007	B

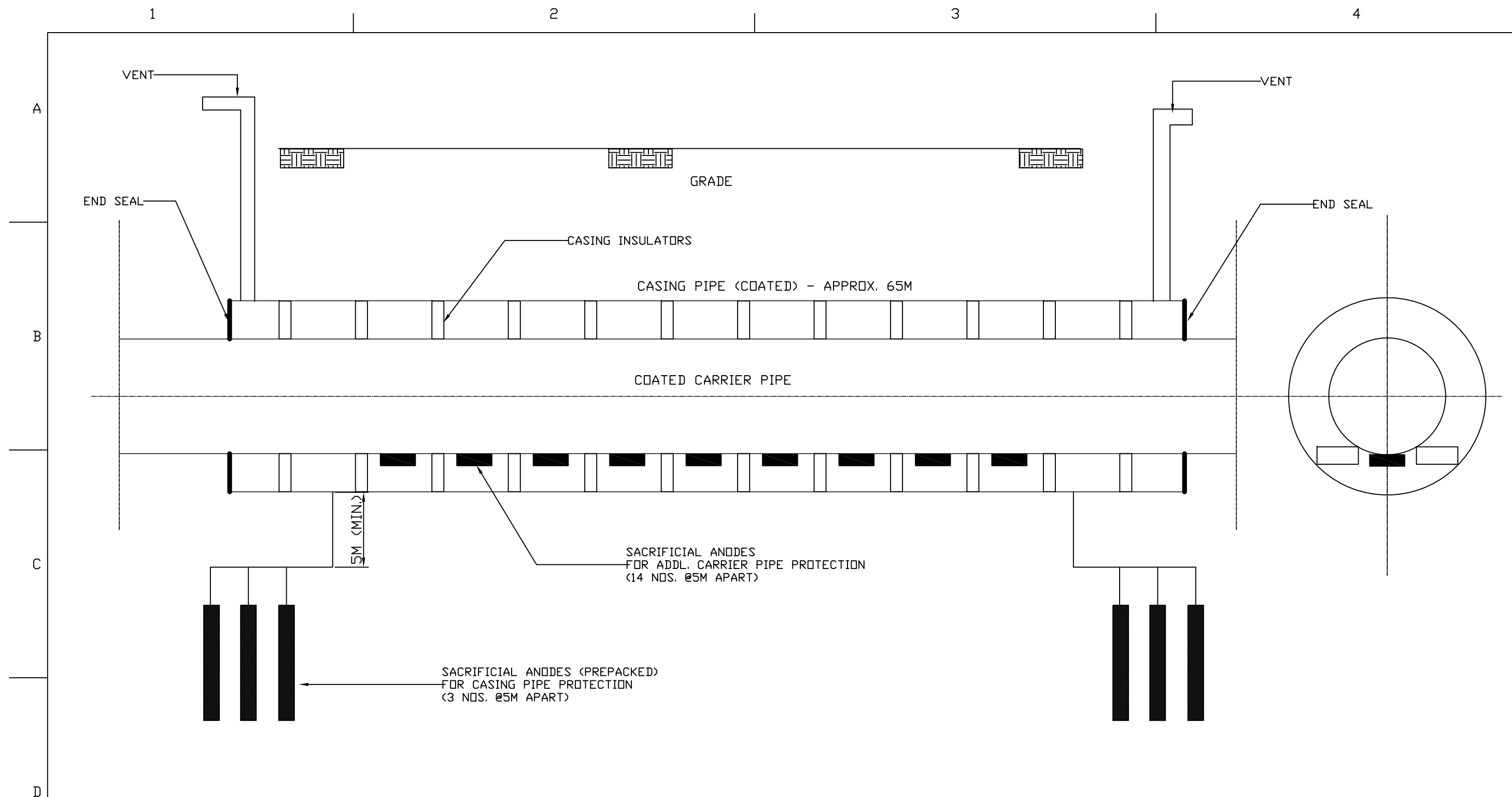

NOTES:

1. CASING PIPE- SACRIFICIAL ANODE CATHODIC PROTECTION AT THE TWO ENDS TO INDEPENDENTLY PROTECT THE CASING PIPE FROM RAVAGES OF SOILSIDE CORROSION.
2. CARRIER PIPE - ICCP IS ALREADY PROTECTING THE CARRIER PIPE. IN ADDITION SACRIFICIAL ANODES ARE INSTALLED, AS ABOVE, BETWEEN 4-7 O' CLOCK POSITION TO COUNTER ELECTROLYTE.
3. CASINGS OVER 20mtr. LENGTH SHALL HAVE ADDITIONAL CATHODIC PROTECTION FOR CARRIER PIPE BOTTOM AND THE ANNULUS SHALL BE PACKED WITH SAND OR BENTONITE.
4. CASINGS LESS THAN 20mtr. LENGTH SHALL NOT HAVE ADDITIONAL CATHODIC PROTECTION FOR CARRIER PIPE BOTTOM AND THE ANNULUS SHALL BE PACKED WITH SAND OR BENTONITE.

NO	DATE	REVISION	BY	CHKD	APPD.
B	04.07.11	ISSUED FOR CLIENT APPROVAL	VSR	SB	HM
A	01.07.11	ISSUED FOR IDC	VSR	SB	HM

PMC **jp kenny** WOOD GROUP KENNY INDIA PVT. LTD.  
NEW DELHI

TITLE: TYPICAL CATHODIC PROTECTION SCHEME FOR CASED CROSSINGS			
SCALE	-	DRAWING NUMBER	REV
N.T.S.	-	1-10-008	B

1

2

3

4

A

B

C

D

E

ANODE JUNCTION BOX  
TO TRU

A12

A11

A10

A3

A2

A1

3M  
2M

5M

5M

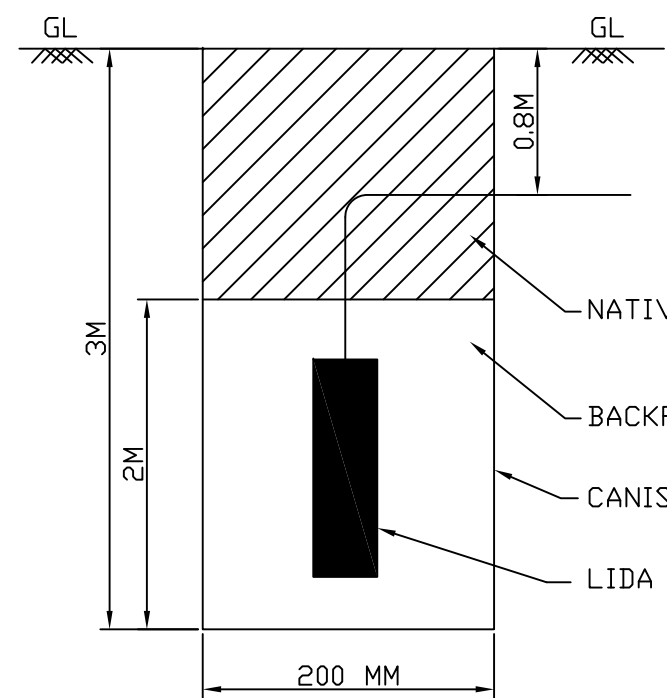

B	04.07.11	ISSUED FOR CLIENT APPROVAL	VSR	SB	HM
A	01.07.11	ISSUED FOR IDC	VSR	SB	HM
NO	DATE	REVISION	BY	CHKD	APPD.

PMC **jp kenny** WOOD GROUP KENNY INDIA PVT. LTD.  
NEW DELHI

TITLE:  
INSTALLATION DETAILS OF LIDA SINGLE ANODES

SCALE	-	DRAWING NUMBER	REV
N.T.S.	-	1-10-009	B

1

2

3

4

A

B

C

D

E

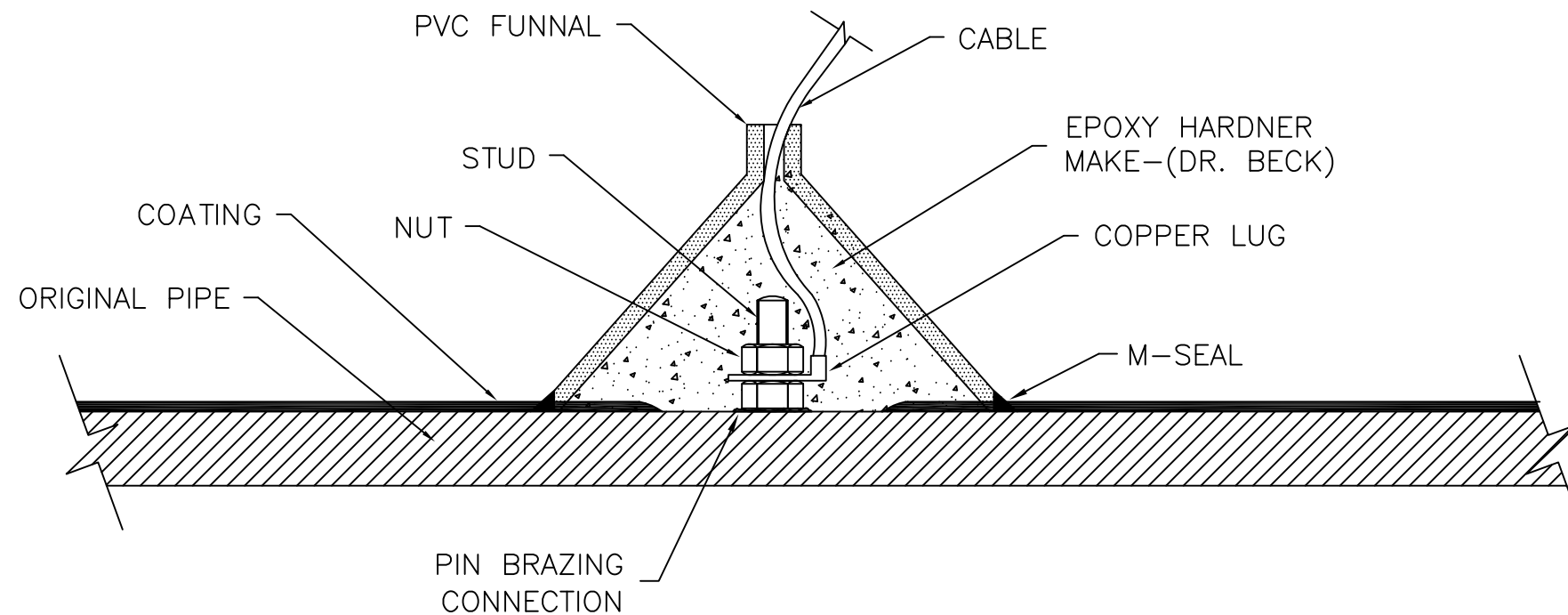

**NOTE :**

1. INSTRUCTIONS APPEARING WITH THIS DRG IS SUITABLE FOR COPPER CONNECTIONS.
2. FOR SEALING THE COMPLETED JOINT SEAL WITH EPOXY RESIN FORMULATION ENSURING THAT EVERY METALLIC PART OF THE JOINT IS COMPLETELY INSULATED. M-SEAL SHALL BE APPLIED AT THE EDGE OF THE EPOXY RESIN TO SEAL THE EPOXY RESIN AND PE TAR COATING.
3. STUD SIZE 8mm.

B	04.07.11	ISSUED FOR CLIENT APPROVAL	VSR	SB	HM
A	01.07.11	ISSUED FOR IDC	VSR	SB	HM
NO	DATE	REVISION	BY	CHKD	APPD.

PMC  
 WOOD GROUP KENNY INDIA PVT. LTD.  
 NEW DELHI

TITLE:  
 CABLE TO PIPE JOINT BY PIN BRAZING

SCALE	-	DRAWING NUMBER	REV
N.T.S.	-	1-10-010	B

1

2

3

4

A

B

C

D

E

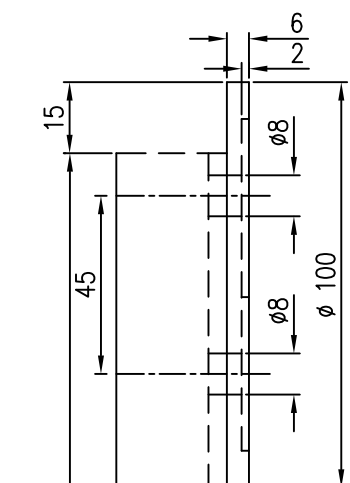

460

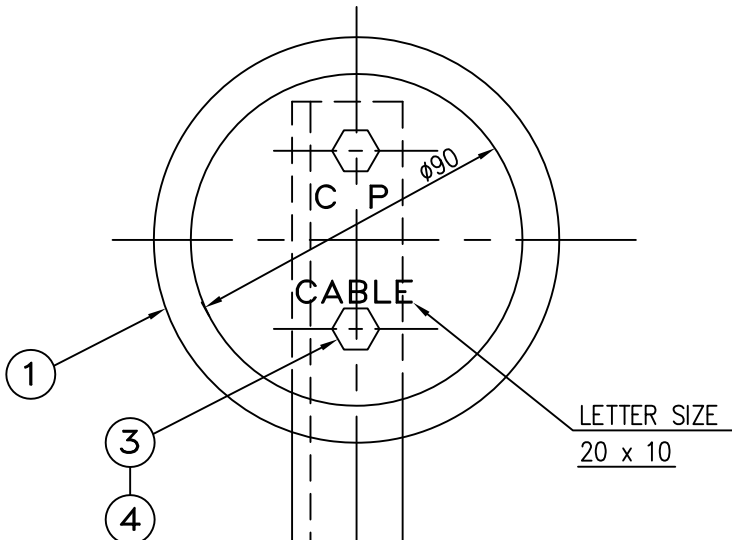
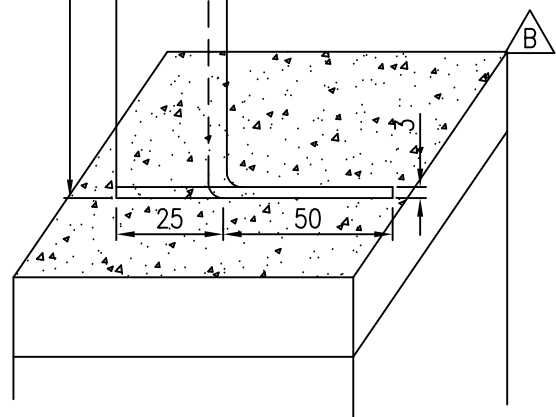

LETTER SIZE  
20 x 10

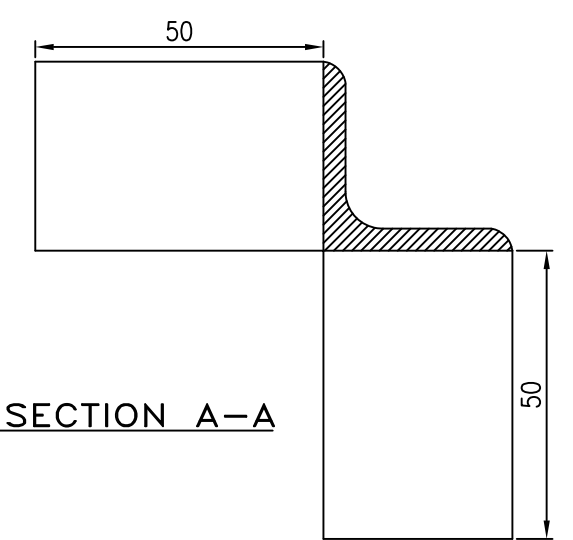
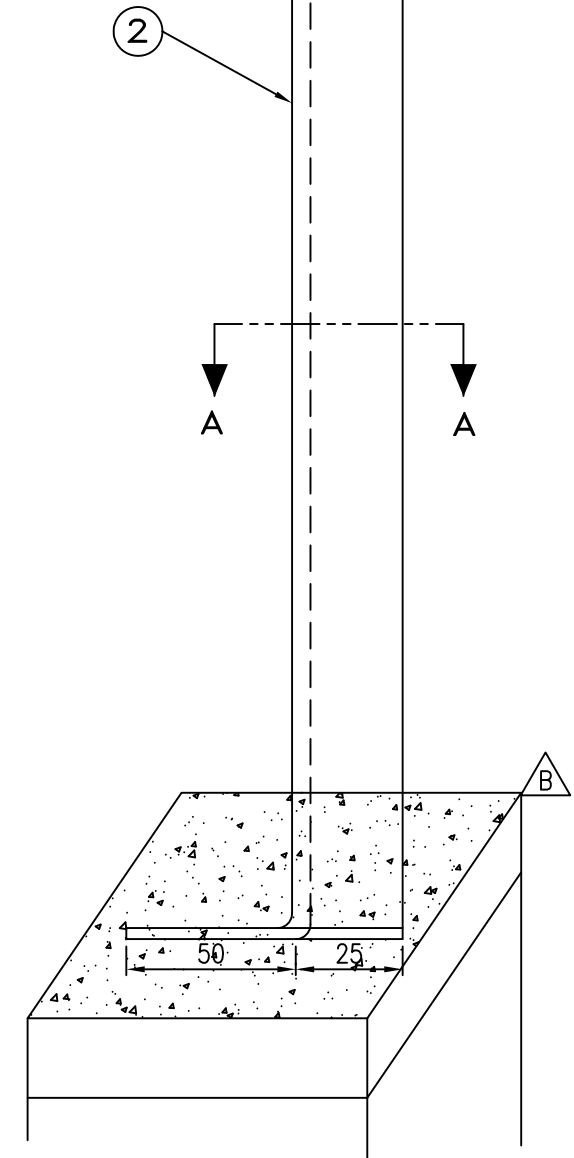

SECTION A-A

**BILL OF MATERIAL**

SL NO.	DESCRIPTION	QTY.
1.	MARKER PLATE (CAST IRON)	1 NO.
2.	M.S. ANGLE 25x25x510 LONG	1 NO.
3.	BOLTS M6x20 LONG	2 NOS.
4.	NUTS M6	2 NOS.

**NOTES:**

1. ALL DIMENSION ARE IN MM
2. IN CASE OF POWER CABLE REPLACE "C.P" WITH "POWER"
3. THE CABLE MARKER SHALL BE PAINTED WITH APPROVED GRADE ALUMINIUM PAINT.

NO	DATE	REVISION	BY	CHKD	APPD.
B	04.07.11	ISSUED FOR CLIENT APPROVAL	VSR	SB	HM
A	01.07.11	ISSUED FOR IDC	VSR	SB	HM

PMC **jpkenney** WOOD GROUP KENNY INDIA PVT. LTD.  
NEW DELHI

TITLE:  
FABRICATION AND INSTALLATION DETAILS OF CABLE  
ROUTE MARKER

SCALE	-	DRAWING NUMBER	REV
N.T.S.	-	1-10-011	B